

Shihlin Electric General Inverters

SC3 Series

User Manual

High price–performance ratio

SC3-021-0.2K ~ 2.2K

SC3-023-0.2K ~ 3.7K

SC3-043-0.4K ~ 5.5K

SC3-043-7.5K/11KF~18.5K/22KF

SC3-043-22K

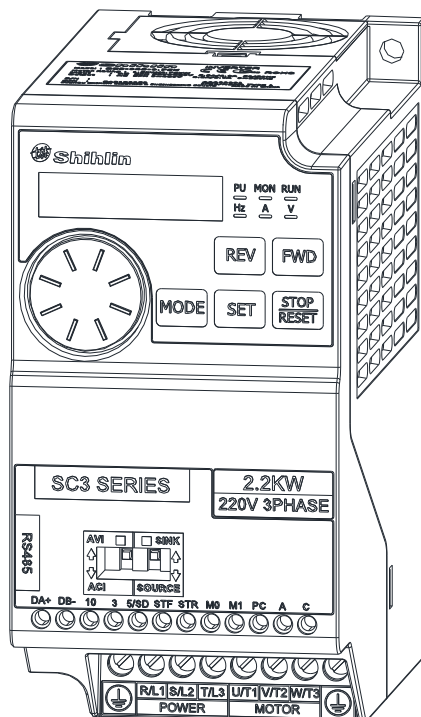

MANUAL GUIDE	1
DELIVERY CHECK	2
INVERTER INTRODUCTION	3
BASIC OPERATION	4
PARAMETER DESCRIPTION	5
INSPECTION AND MAINTENANCE	6
APPENDIX	7

1. MANUAL GUIDE

1.1 Safety instructions

Thank you for choosing Shihlin inverters SC3 series. This user manual introduces how to use the product correctly. Please read the user manual carefully before using the product. In addition, please use the product after understanding the safety instructions.

Safety Instructions

- ✓ Installation, operation, maintenance and inspection must be performed by qualified personnel.
- ✓ In this instruction, the safety instruction levels are classified into "Warning" and "Caution".
- ⚠ **Warning:** Incorrect handling may cause hazardous conditions, resulting in death or severe injury.
- ⚠ **Caution:** Incorrect handling may cause hazardous conditions, resulting in medium or slight injury, or may cause only material damage.

Warning

- ✓ While the inverter power is ON, do not open the front cover or the wiring cover. Do not run the inverter with the front cover or the wiring cover removed. Otherwise you may access the exposed high voltage terminals or the charging part of the circuitry and get an electric shock.
- ✓ It is crucial to turn off the inverter power before any wiring installation or inspection is made. Before the inverter screen is OFF, which indicates that there is still high voltage in it, please do not touch the internal circuit and components.
- ✓ The inverter must be connected to the ground properly.
- ✓ Do not operate or touch the heat sink or handle the cables with wet hands. Otherwise you may get an electric shock.
- ✓ Do not change the cooling fan while power is ON. It is dangerous to change the cooling fan while power is ON.

Caution

- ✓ Voltage applied to each terminal must be the one specified in the user manual; otherwise, failure or damage may be caused.
- ✓ Do not operate a voltage-resistant test for the parts inside the inverter because semiconductors in inverter may be easily damaged due to high-voltage breakdown.
- ✓ Do not touch the inverter because the temperature of the inverter is very high when it is powered on or right after disconnecting the power supply; only touch the built-in keypad part. Otherwise, burn may occur.
- ✓ Failure or damage may be caused due to wrong wiring.
- ✓ Do not reverse the polarities (+, -) by mistake, failure or damage may be caused.
- ✓ Please install the inverter on nonflammable walls without holes (to avoid contacts with the cooling fin of the inverter from the back). If the inverter is installed on or close to flammable objects it may cause a fire.
- ✓ Please disconnect the inverter from power supply in case of failure. Overload current passes through the inverter continuously may cause a fire.

Other Precautions:

*1 If the product is ultimately used as a military unit, or when the product is used for weapons manufacturing, etc., this product will be included in the export product control object specified in the "Foreign Trade Law of PRC". When exporting, strict inspection and export procedures are required.

*2 In this manual, the case or the safety cover will be remove, and the description will be made in graphics and text in order to explain the product in detail. When operating, to ensure safety be sure to install the case and wire correctly according to the regulations referred in manual.

*3 Graphics in the manual are slightly different from the actual product for the convenience of illustrating, this will not affect customer rights.

*4 To improve our products, parameters and contents may be modified in the future, and the contents of this manual are subject to change without notice. Please download the latest version from Shihlin website (www.sseec.com.cn or www.seec.com.tw).

1.2 Table of contents

User Manual	1
1. MANUAL GUIDE	1
1.1 Safety instructions.....	1
1.2 Table of contents.....	2
1.3 Definitions of terminologies.....	10
2. DELIVERY CHECK.....	11
2.1 Nameplate instruction.....	11
2.2 Type instruction	11
2.3 Order code description	11
3. INVERTER INTRODUCTION.....	12
3.1 Electric specification	12
3.1.1 440V series three-phase.....	12
3.1.2 220V series three-phase.....	13
3.1.3 220V series single phase.....	14
3.2 General specification	15
3.3 Appearance and dimensions.....	16
3.3.1 Frame A	16
3.3.2 Frame B/C/D	17
3.4 Name of each component.....	18
3.4.1 Frame A/B.....	18
3.4.2 Frame C/D	18
3.5 Installation and wiring	19

3.5.1 Transportation.....	19
3.5.2 Stockpile.....	19
3.5.3 Installation notice	19
3.5.4 EMC installation instructions.....	22
3.6 Peripheral devices.....	23
3.6.1 System Wire Arrangement.....	23
3.6.2 No-fuse breaker and magnetic contactor	24
3.6.3 Regeneration brake resistor	25
3.7 Terminal wire arrangement.....	26
3.7.1 Main circuit Terminals.....	27
3.7.2 Main circuit wiring and terminal specification	28
3.7.3 Ground	29
3.7.4 RFI filter.....	29
3.7.5 Control circuit.....	30
3.8 Replacement procedure of fan.....	34
3.8.1 Frame A/B.....	34
3.8.2 Frame C/D	34
4. BASIC OPERATION	35
4.1 Component name of keypad.....	35
4.2 Operation modes of inverter	36
4.2.1 Flow chart for switching operation mode	37
4.2.2 Flow chart for switching built-in keypad working mode	37
4.2.3 Operation flow chart for monitoring mode	38

4.2.4 Operation flow chart for frequency setting.....	38
4.2.5 Operation flow chart for parameter setting	39
4.2.6 Operation flow chart for HELP mode.....	39
4.3 Basic operation steps for different modes	40
4.3.1 Basic operation steps for PU mode (00-16(P.79) = 0 or 1)	40
4.3.2 Basic operation steps for external mode (00-16(P.79) = 0 or 2)	40
4.3.3 Basic operation steps for JOG mode (00-16(P.79) = 0 or 1).....	41
4.3.4 Basic operation steps for communication mode (00-16(P.79) = 3)	41
4.3.5 Basic operation steps for combined mode 1 (00-16(P.79) = 4).....	41
4.3.6 Basic operation steps for combined mode 2 (00-16(P.79) = 5).....	42
4.3.7 Basic operation steps for combined mode 3(00-16(P.79) = 6).....	42
4.3.8 Basic operation steps for combined mode 4(00-16(P.79) = 7).....	43
4.3.9 Basic operation steps for combined mode 5(00-16(P.79) = 8).....	43
4.4 Operation.....	44
4.4.1 Check and preparation before running.....	44
4.4.2 Running methods.....	44
4.4.3 Test run.....	45
5. PARAMETER DESCRIPTION	46
5.1 System parameter group 00.....	46
5.1.1 Inverter information.....	49
5.1.2 Parameter restoration	50
5.1.3 Parameter protection	52
5.1.4 Monitoring function.....	54
5.1.5 Speed display	55

5.1.6 Built-in keypad set target frequency selection.....	56
5.1.7 PWM carrier frequency	57
5.1.8 Stop operation selection	58
5.1.9 Forward/reverse rotate prevent function	59
5.1.10 Operation mode selection.....	59
5.1.11 Motor control mode selection	60
5.1.12 Motor types selection.....	60
5.1.13 50/60Hz switch selection	61
5.1.14 Parameter mode setting	61
5.2 Basic Parameter Group 01	62
5.2.1 Limiting the output frequency	64
5.2.2 Base frequency, base voltage	65
5.2.3 Acceleration/deceleration time setting.....	66
5.2.4 Torque boost V/F	68
5.2.5 Starting frequency.....	68
5.2.6 Load pattern selection V/F	69
5.2.7 JOG run.....	71
5.2.8 Output frequency filter time.....	72
5.2.9 Frequency jump	72
5.2.10 Second function	74
5.2.11 Middle frequency, output voltage of middle frequency V/F	75
5.2.12 S pattern time.....	76
5.2.13 Remote function acc/dec time selection	77

5.3 Analog input and output parameter group 02	78
5.3.1 Proportional linkage gain	79
5.3.3 Terminal 3-5 signal selection and processing	80
5.3.4 Inverter rated current display level	85
5.4 Digital input/ output parameter group 03	86
5.4.1 Digital input terminals function selection	89
5.4.2 Digital output terminals function selection	93
5.4.3 Terminal logic selection	94
5.4.4 Digital output signal delay	95
5.4.5 Digital input signal filter	95
5.4.6 Digital input terminal enable when power on.....	96
5.4.7 Output frequency detection.....	96
5.4.8 Zero current detection.....	97
5.5 Multi-speed parameter group 04.....	98
5.5.1 16 steps speed.....	100
5.5.2 Programmed operation mode	102
5.6 Motor parameter group 05	105
5.6.1 Motor parameter automatic measurement	105
5.6.2 Motor parameter	107
5.7 Protection parameter group 06	108
5.7.1 Electronic thermal relay capacity	110
5.7.3 Regenerative brake	112
5.7.4 Over torque detection	113
5.7.5 Cooling fan working mode	114

5.7.6 Maintenance alarm function.....	114
5.7.7 Short circuit to ground protection.....	114
5.7.9 Time record function	115
5.7.11 Fire mode.....	117
5.8 Communication parameter group 07.....	119
5.8.1 Shihlin protocol and Modbus protocol	120
5.8.2 Communication EEPROM write selection	135
5.9 PID parameter group 08.....	136
5.9.1 PID function selection	137
5.9.2 PID parameter group	137
5.9.3 PID pressure range setting.....	141
5.9.4 PID analog signal feedback loss	141
5.10 Application parameter group 10.....	142
5.10.1 DC injection brake	144
5.10.2 Zero-speed control.....	145
5.10.3 DC injection brake before start	145
5.10.4 Restart mode selection	146
5.10.5 Remote setting function selection.....	147
5.10.6 Auto reset function	149
5.10.7 Forward and reverse rotation dead time	150
5.10.8 Energy-saving function V/F	150
5.10.9 Dwell function V/F	151
5.10.10 Triangular wave function V/F	152

5.10.11 Voltage stall action level	153
5.10.12 Reciprocating machine function	153
5.11 Advanced parameter group 11	155
5.11.1 Slip compensation gain.....	155
5.11.2 Torque boost filter	155
5.11.3 Current filter	155
5.12 Special Adjustment Parameter Group 13.....	156
5.12.1 Slip Compensation V/F	156
5.12.2 Vibration inhibition	156
5.13 User registered parameter 15	157
5.13.1 User registered parameter.....	158
6. INSPECTION AND MAINTENANCE.....	160
6.1 Inspection item.....	160
6.1.1 Daily inspection item	160
6.1.2 Regular inspection items	160
6.1.3 Ways to measure voltage, current, power on main circuit	161
6.1.4 Cleaning.....	161
6.1.5 Replacement parts.....	162
6.2 Ways to measure voltage, current, power on main circuit.....	163
6.2.1 Selecting measurement instruments	163
6.2.2 Measurement of voltage	163
6.2.3 Measurement of current.....	163
6.2.4 Measurement of power	163
6.2.5 Measurement of insulation resistance.....	164

6.2.6 Hi-pot test.....	164
7. Appendix.....	165
7.1 Appendix 1 Parameter table.....	165
7.1.1 Parameter in P sequence	165
7.1.2 Group mode	181
7.2 Appendix 2 Alarm code list	197
7.3 Appendix 3 : Warning code list.....	201
7.4 Appendix 4:Troubles and solutions	202
7.5 Appendix 5 Optional equipment.....	203
7.5.1 PU301 Keypad	203
7.5.2 DU06 Keypad	205
7.5.3 DU08 Keypad	206
7.5.4 DU10 Keypad	208
7.5.5 PU302 Keypad	209
7.5.6 CBL : Data transmission line (for use with the above keypads)	210
7.6 Appendix 6 European Specification Compatibility Description.....	211
8. REVISION RECORD	214

1.3 Definitions of terminologies

✓ Output frequency, target frequency, steady output frequency

- The actual output current frequency of inverter is called “output frequency.”
- The frequency set by user (via built-in keypad, multi-speed terminals, voltage signal, and current signal or communication settings) is called “target frequency.”
- When motor starts running, inverter output frequency will gradually accelerate to target frequency before it finally runs steadily at the target frequency. This output frequency is called “steady output frequency.”

✓ Parameter settings

- Detail explanation on parameter settings are provided in Chapter 5. For users who are not familiar with these settings, arbitrary adjustment of the parameter may result in abnormal operations. All parameters can be reset to their default values by the parameter 00-02(P.996~P.999). For setting procedures of this parameter, please refer to 00-02(P.996~P.999) in Section 5.1.2.

✓ The “operation mode” and “working mode” of the built-in keypad

- Target frequency command source and start signal source depend on inverter operation mode. There are nine operating modes in Shihlin inverter. Please refer to Section 4.3 for details.
- Built-in keypad is used mainly for monitoring the numeric values, setting parameters and target frequency. Please refer to Section 4.2 for details.

✓ The difference between “terminal name” and “function name”:

- Printed letters can be found near the terminals on control board and main board. They are used to distinguish each terminal and are called “terminal name.”
- For “multi-function control terminal” and “multi-function output terminal,” besides the terminal name, it is also necessary to define the “function name.” The function name indicates the actual functions of the terminal.
- When explaining the function for a terminal, the name used is its “function name”.

✓ The difference between “on” and “turn on”:

- When explaining the function for the “multi-function digital input terminal”, two words “on” and “turn on” are often used:
- The word “on” is used to indicate that the external switch of the terminal is in close state, and thus it belongs to the description of the state.
- The word “turn on” is used to describe the action that the external switch of the terminal is shut from the open state to the close state, and thus belongs to the description of action. Similarly, the words “off” and “turn off” belong to the above-mentioned states and actions.

✓ P.XXX

- P.XXX refers to parameter number, not page number.

2. DELIVERY CHECK

Each SC3 inverter has been checked thoroughly before delivery, and is carefully packed to prevent any mechanical damage. Please check for the following when opening the package.

- Check whether the product was damaged during transportation.
- Whether the model of inverter is the same with what is shown on the package.

2.1 Nameplate instruction

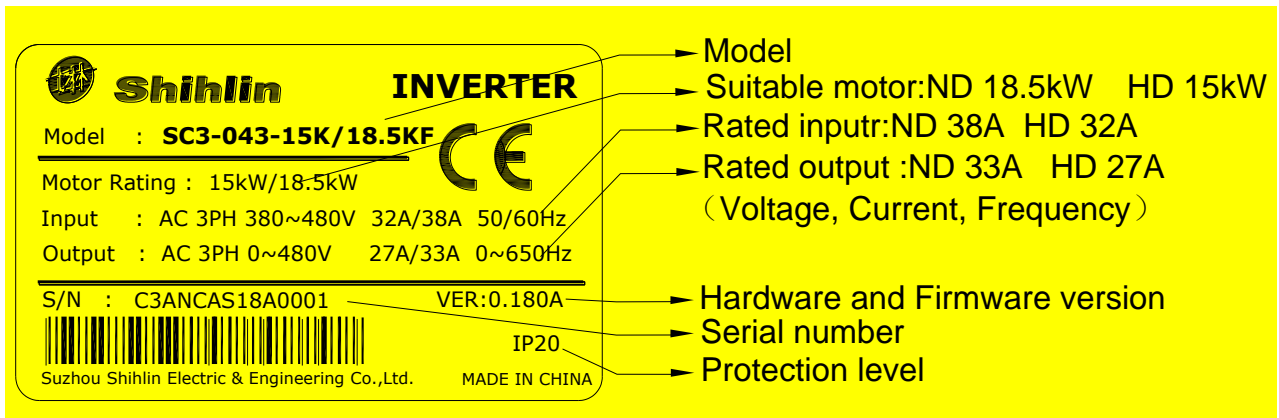

2.2 Type instruction

SC3-043-7.5K/11KF - xy

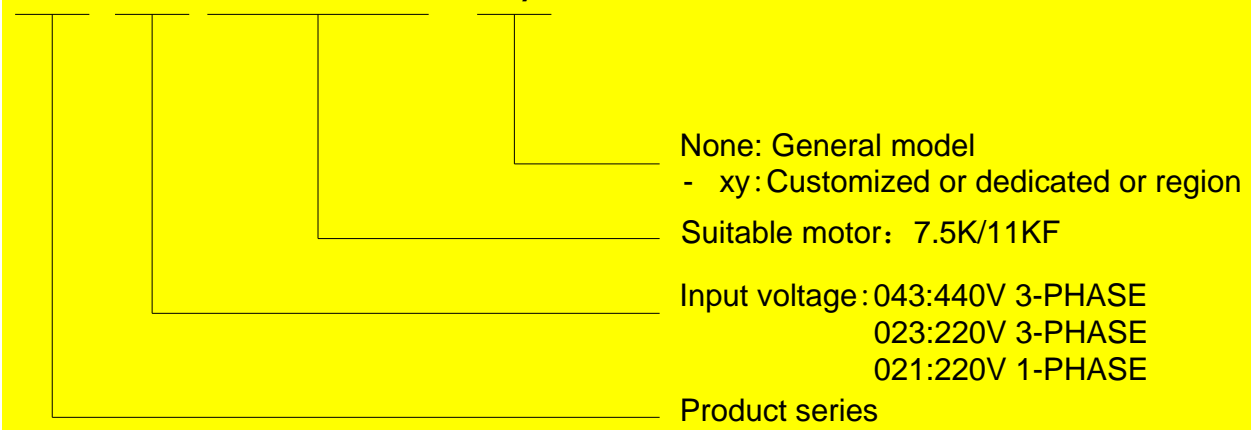

2.3 Order code description

Example:

Inverter specification	Specification description	Order code
SC3-021-1.5K	SC3 series single phase 220V 1.5kW inverter	SNKSC30211R5K
SC3-023-1.5K	SC3 series three phase 220V 1.5kW inverter	SNKSC30231R5K
SC3-043-1.5K	SC3 series 440V 1.5kW inverter	SNKSC30431R5K

3. INVERTER INTRODUCTION

3.1 Electric specification

3.1.1 440V series three-phase

Frame		A			B		
SC3-043-□□□K-xy		0.4	0.75	1.5	2.2	3.7	5.5
Inverter Output	Rated output capacity (kVA)	1	2	3	4.6	6.9	9.2
	Rated output current (A)	1.5	2.6	4.2	6	9	12
	Applicable motor capacity (HP)	0.5	1	2	3	5	7.5
	Applicable motor capacity (kW)	0.4	0.75	1.5	2.2	3.7	5.5
	Overload current rating	150% 60 seconds, 200% 1 seconds (inverse-time characteristics)					
	Carrier frequency (kHz)	1~15kHz					
	Maximum output voltage	3 phase 380-480V					
Power Supply	Rated input current (A) *Note 1	3 phase 380-480V 50Hz / 60Hz					
	Rated input AC voltage/ frequency	3 phase 323-528V 50Hz / 60Hz					
	Permissible AC voltage fluctuation	±5%					
	Permissible frequency fluctuation	1.5	2.5	4.5	6.9	10.4	11.5
	Power supply capacity (kVA)	1.8	3.2	4.3	7.1	10	14
Cooling method		No fan	Fan cooling				
Weight (kg)		0.74	0.74	0.81	1.37	1.37	1.42

Frame		C		D			
Model SC3-043-□□K□KF-xy		7.5/11	11/15	15/18.5	18.5/22	22	
Inverter Output	HD	Rated output capacity kVA	14	18	25	29	34
		Rated output current A	18	24	32	38	45
		Applicable motor capacity HP	10	15	20	25	30
		Applicable motor capacity kW	7.5	11	15	18.5	22
		Overload current rating	150% 60 seconds (inverse-time characteristics)				
		Carrier frequency kHz	1~15kHz				
	ND	Rated output capacity kVA	18	25	29	34	46
		Rated output current A	24	32	38	45	49
		Applicable motor capacity HP	15	20	25	30	30
		Applicable motor capacity kW	11	15	18.5	22	22
		Overload current rating	120% 60 seconds (inverse-time characteristics)				
		Carrier frequency kHz	1~15kHz		1~10kHz		
	Maximum output voltage		3 phase 380-480V				
Power Supply	Rated input AC voltage/ frequency		3 phase 380-480V 50Hz / 60Hz				
	Permissible AC voltage fluctuation		3 phase 323-528V 50Hz / 60Hz				
	Permissible frequency fluctuation		±5%				
	Power supply capacity kVA		16	20	27	32	41
	Rated input current A	HD	20	26	35	40	47
ND		26	35	40	47	54	
Cooling method		Fan cooling					
Weight kg		2.07	2.15	3.45	3.57	3.70	

Note 1: The value indicates the current at rated output. The rated input current value is not only affected by power transformer, input side reactor, wiring condition, but also fluctuates with the impedance of the power supply side.

3.1.2 220V series three-phase

Frame		A				B	
Model SC3-023-□□□K-xy		0.2	0.4	0.75	1.5	2.2	3.7
Inverter Output	Rated output capacity (kVA)	0.6	1.2	2	3.2	4.2	6.7
	Rated output current (A)	1.8	3	5	8	11	17.5
	Applicable motor capacity (HP)	0.25	0.5	1	2	3	5
	Applicable motor capacity (kW)	0.2	0.4	0.75	1.5	2.2	3.7
	Overload current rating	150% 60 seconds, 200% 1 seconds (inverse-time characteristics)					
	Carrier frequency (kHz)	1~15kHz					
	Maximum output voltage	3 phase 200-240V					
Power Supply	Rated input current (A) *Note 1	3 phase 200-240V				50Hz / 60Hz	
	Rated input AC voltage/ frequency	3 phase 170-264V				50Hz / 60Hz	
	Permissible AC voltage fluctuation	±5%					
	Permissible frequency fluctuation	0.75	1.5	2.5	4.5	6.4	10
	Power supply capacity (kVA)	2.1	3.2	5.6	9.3	15	20.6
Cooling method		No fan	Fan cooling				
Weight (kg)		0.69	0.69	0.70	0.73	1.32	1.4

Note 1: The value indicates the current at rated output. The rated input current value is not only affected by power transformer, input side reactor, wiring condition, but also fluctuates with the impedance of the power supply side.

3.1.3 220V series single phase

Frame		A			B	
Model SC3-021-□□□K-xy		0.2	0.4	0.75	1.5	2.2
Inverter Output	Rated output capacity (kVA)	0.6	1	1.5	2.5	4.2
	Rated output current (A)	1.8	2.7	4.5	8	11
	Applicable motor capacity (HP)	0.25	0.5	1	2	3
	Applicable motor capacity (kW)	0.2	0.4	0.75	1.5	2.2
	Overload current rating	150% 60 seconds, 200% 1 seconds (inverse-time characteristics)				
	Carrier frequency (kHz)	1~15kHz				
	Maximum output voltage	3 phase 200-240V				
Power Supply	Rated input current (A) *Note 1	single phase 200-240V 50Hz / 60Hz				
	Rated input AC voltage/ frequency	single phase 170-264V 50Hz / 60Hz				
	Permissible AC voltage fluctuation	±5%				
	Permissible frequency fluctuation	0.75	1.5	2.5	3.5	6.4
	Power supply capacity (kVA)	5.4	6.5	9.3	15.7	24
Cooling method		No fan	Fan cooling			
Weight (kg)		0.66	0.68	0.73	1.38	1.4

Note 1: The value indicates the current at rated output. The rated input current value is not only affected by power transformer, input side reactor, wiring condition, but also fluctuates with the impedance of the power supply side.

3.2 General specification

Control method		SVPWM , V/F control , General flux vector control
Output frequency range		0~599Hz (*1)
Frequency setting resolution	Digital setting	Within 100Hz, the resolution is 0.01Hz Above 100Hz, the resolution is 0.1Hz.
	Analog setting	DC 0~5V or 4~20mA signal: 11 bit, DC 0~10V signal: 12 bit.
Output frequency accuracy	Digital setting	Maximum target frequency±0.01%.
	Analog setting	Maximum target frequency±0.1%.
Starting torque		Under General flux vector control: 180%/3Hz, 200%/5Hz
V/F characteristics		Constant torque curve, variable torque curve, five-point VF curve
Acceleration / deceleration curve characteristics		Linear acceleration /deceleration curve, S shape acceleration /deceleration curve 1 & 2 & 3
Drive motor		Induction motor (IM)
Stalling protection		The stalling protection level can be set from 0~250%. Default value 150%
Target frequency setting		Built-in keypad setting, DC 0~5V/10V signal, DC 4~20 mA signal, multi-speed stage level setting, communication setting.
Built-in keypad	Operation monitoring	Output frequency, output current, output voltage, PN voltage , electronic thermal accumulation rate, temperature rising accumulation rate, output power, analog input signal value, digital input and output terminal status...; alarm history 12 sets with operation details of the latest two set.
	LED indicator (6)	Frequency monitoring indicator, voltage monitoring indicator, current monitoring indicator, motor running indicator, mode switch indicator, PU mode indicator.
Communication function		RS485 communication, choose between Shihlin/Modbus communication protocol, baud rate up to 115200bps.
Protection mechanism / alarm function		Output short circuit protection, over-current protection, over-voltage protection, under-voltage protection, motor over-heat protection (06-00(P.9)), IGBT module over-heat protection, communication error protection, PID error protection, memory error protection, CPU error protection, stall prevention, module over-heat protection, input power fail protection, terminal 3-5 disconnect protection, over torque protection, Current leakage to ground protection, hardware detect circuit error protection
Environment	Ambient temperature	-10 ~ +50°C(non-freezing) , side by side installation-10~ +40°C(non-freezing).
	Ambient humidity	Below 90%Rh (non-condensing).
	Storage temperature	-20 ~ +65°C.
	Surrounding environment	Indoor, no corrosive gas, no flammable gas, no flammable powder.
	Altitude	Altitude below 2000 meters, when altitude is above 1,000 m, derate the rated current 2% per 100m
	Vibration	Vibration below 5.9m/s ² (0.6G)
	Grade of protection	IP20
	Over voltage level	II
	Degree of environmental pollution	2
	Class of protection	Class I
International certification		CE

*1: Even if the frequency related parameter setting is greater than 599Hz, the actual output frequency upper limit is still 599Hz.

3.3 Appearance and dimensions

3.3.1 Frame A

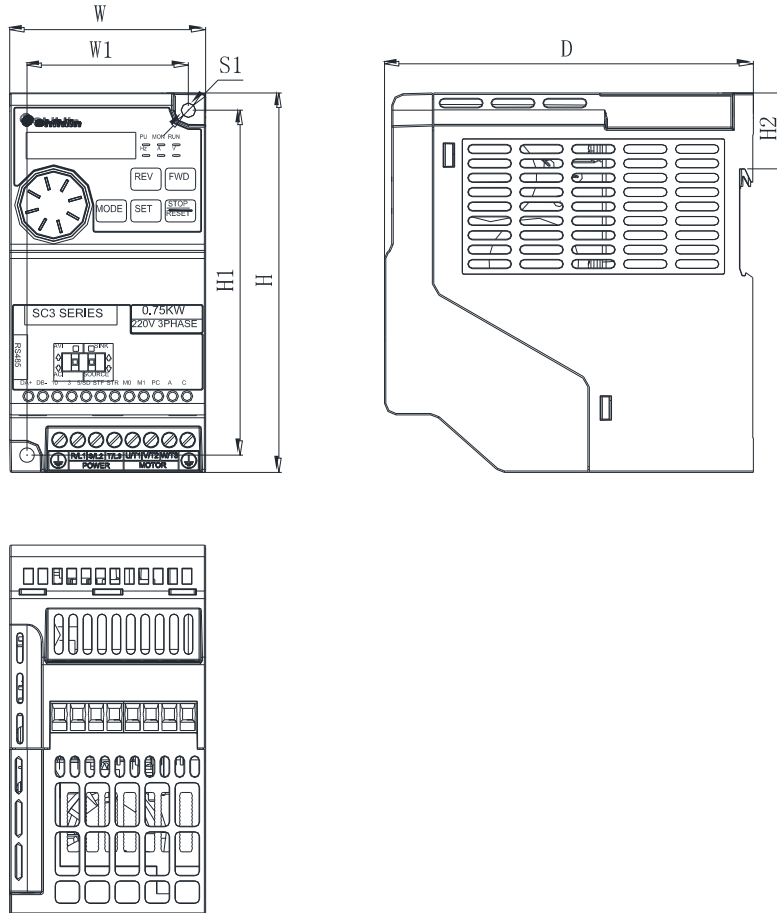

unit : mm

Model	W	W1	H	H1	H2	D	S1
SC3-021-0.2K	68	56	132	120	26.5	128	5 (tighten torque 20~25kgf.cm)
SC3-021-0.4K							
SC3-021-0.75K							
SC3-023-0.2K							
SC3-023-0.4K							
SC3-023-0.75K							
SC3-023-1.5K							
SC3-043-0.4K							
SC3-043-0.75K							
SC3-043-1.5K							

3.3.2 Frame B/C/D

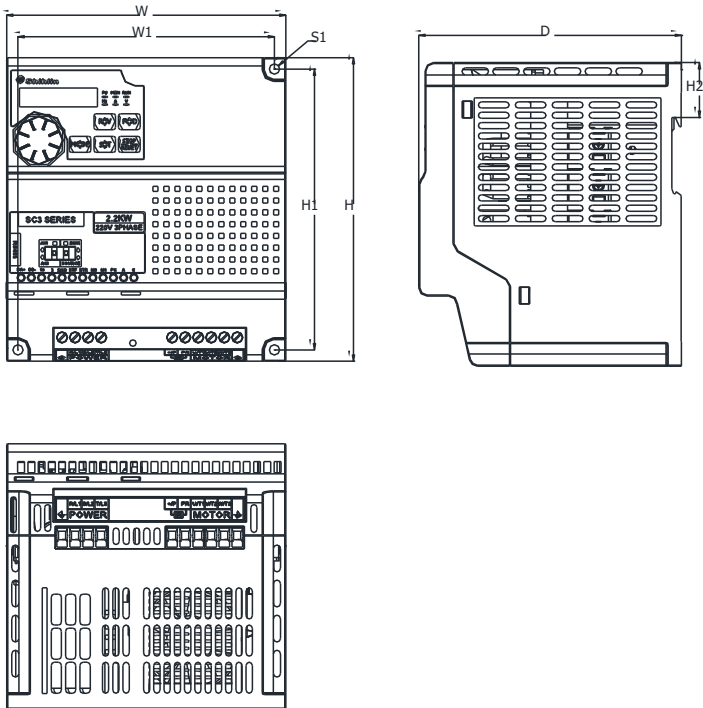

unit : mm

Model	W	W1	H	H1	H2	D	S1
SC3-021-1.5K	136	125	147	136	26.5	128	5 (tighten torque 20~25kgf.cm)
SC3-021-2.2K							
SC3-023-2.2K							
SC3-023-3.7K							
SC3-043-2.2K							
SC3-043-3.7K							
SC3-043-5.5K							
SC3-043-7.5K/11KF	132	115.6	215	198.6	Note 1	150	6.2 (tighten torque 20~25kgf.cm)
SC3-043-11K/15KF	175	158.6	260	243.6	Note 1	180	6.2 (tighten torque 20~25kgf.cm)
SC3-043-15K/18.5KF							
SC3-043-18.5K/22KF							
SC3-043-22K							

Note1: Frame C and frame D do not have this feature, that is, they do not support DIN rail installation

3.4 Name of each component

3.4.1 Frame A/B

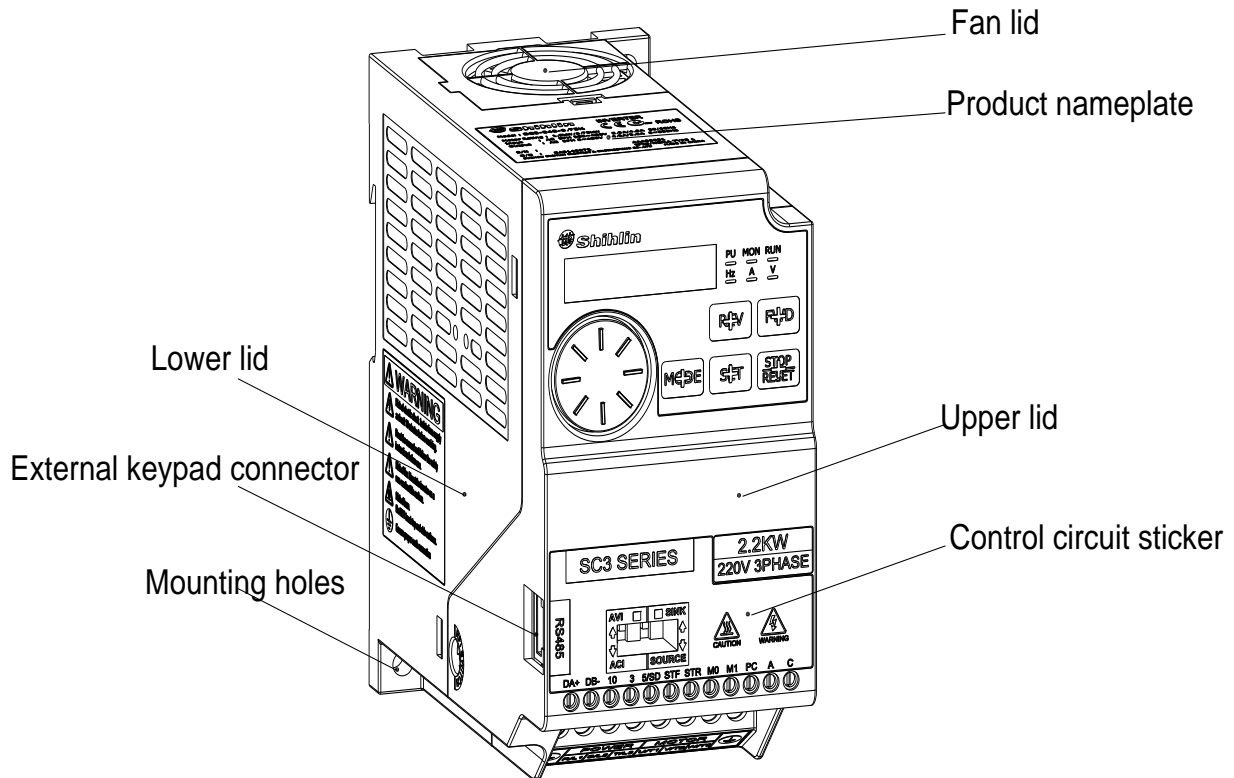

3.4.2 Frame C/D

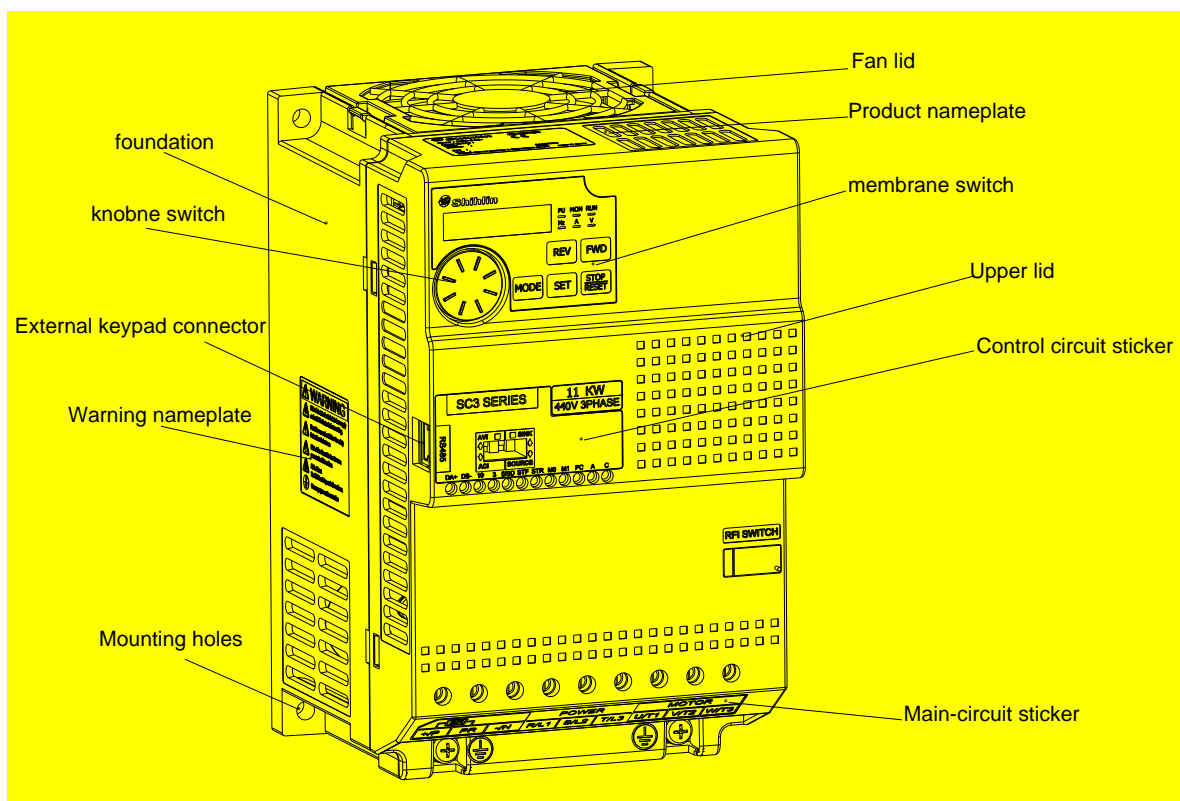

3.5 Installation and wiring

3.5.1 Transportation

Hold the body when carrying and don't only hold the cover or any part of the inverter, otherwise it may drop down.

3.5.2 Stockpile

The product must be placed in the packaging box before installation. In order to make the product conform to the scope of warranty of the company and facilitate maintenance in the future, please pay attention to the following matters when storing if the inverter will not be used temporarily:

1. Must be placed in dry places without dirt and dust.
2. The environment temperature for storage place must range from -20°C to $+65^{\circ}\text{C}$.
3. The relative humidity for storage place must range from 0% to 95%, and no condensation.
4. Avoid storing in the environment containing corrosive gas or liquid.
5. It's better to be packed properly and kept on shelf or table.

Note: 1. Even if the storing place humidity meets the standard requirements, icing and condensation can also occur if the temperature changes rapidly, thus should be avoided.

2. Don't place it on the ground, it should be placed on a shelf. If the environment is bad, put desiccant in the packaging bag.
3. If the storage period is more than 3 months, the storing temperature should not be higher than 30°C . Considering that capacitors will easily degrade in high temperature without being powered on.
4. If the inverter is installed in a machine or control panel when not in use (especially in construction site or humid and dusty places), the inverter should be removed and put in suitable environment according to the above storage conditions.
5. If the inverter isn't power on for a long time, the capacitors will degrade. Do not place it for more than one year without being powered on.

3.5.3 Installation notice

It is recommended that when installing the inverter, it must be far away from heat and radiation sources that can damage the inverter.

✓ Before installing, please confirm whether meet the conditions listed in the table below:

Ambient temperature	$-10 \sim +50^{\circ}\text{C}$ (non-freezing), side by side installation $-10 \sim +40^{\circ}\text{C}$ (non-freezing)
Ambient humidity	Below 90%Rh (non-condensing).
Storage temperature	$-20 \sim +65^{\circ}\text{C}$
Surrounding environment	Indoor, no corrosive gas, no flammable gas, no flammable powder.
Altitude	Altitude below 2000 meters, when altitude is above 1,000 m, derate the rated current 2% per 100 m
Vibration	Vibration below 5.9m/s^2 (0.6G).
Grade of protection	IP20
The degree of environmental pollution	2

✓ Please install the inverter vertically in order not to reduce the heat dissipation effect:

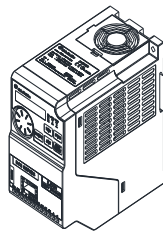

(a) Vertical installation

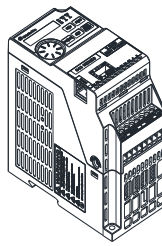

(b) Horizontal installation

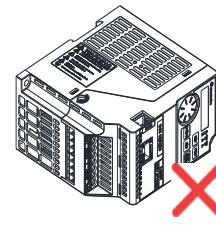

(c) Transverse installation

✓ Please follow the installation restrictions shown below to ensure enough ventilation space for inverter cooling and wiring space:

• Arrangement of single or paralleling inverter :

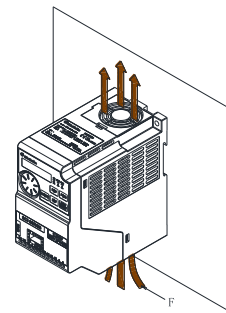
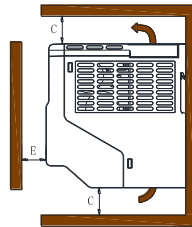
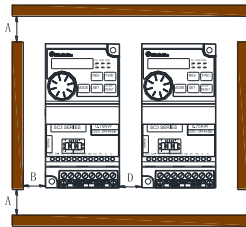

unit : mm

Size	Frame A	Frame B
A	50	50
B	50	50
C	100	100
D	50	50
E	50	50
F	Ventilation direction	

• Arrangement of multiple inverters:

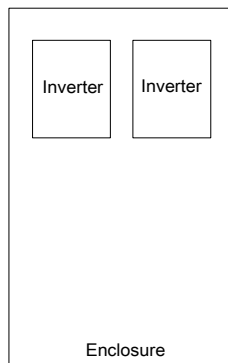

(a) Horizontal arrangement

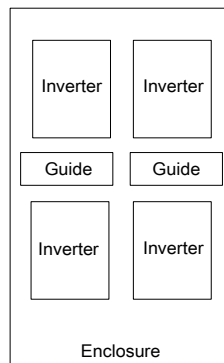

(b) Vertical arrangement

- Note : 1. When installing inverters of different sizes in parallel, please align the upper positions of the inverters before installing. For easier replacement of the cooling fan.
2. When it is inevitable to arrange inverters vertically to minimize space , install guides since heat from the bottom inverters can increase the temperature on the top inverters, causing inverter failures.
3. Side-by-side installation, that is, when “D” is 0, ensure that the ambient temperature in the cabinet is not higher than 40°C, and it is not possible to use external keypad or communicate with upper computer through RS485 interface.

- Din rail installation :

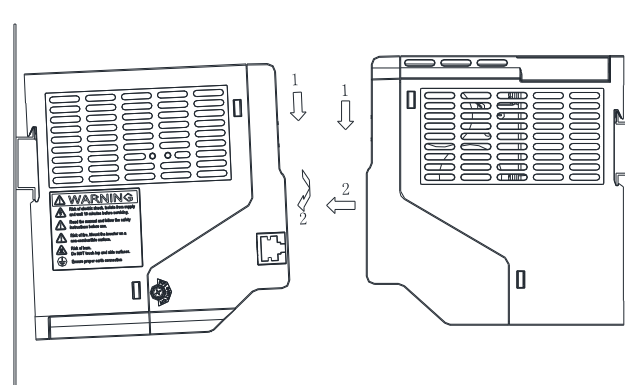

(a) DIN rail mounting

(b) DIN rail remove

Note: Not suitable for frame C and frame D

3.5.4 EMC installation instructions

Just as other electrical and electronic equipment, an inverter is the source of electromagnetic interference and an electromagnetic receiver when working with a power system. The amount of electromagnetic interference and noise is determined by the working principles of an inverter. In order to guarantee the inverter working reliably in the electromagnetic environment, it must have a certain ability of anti-electromagnetic interference in design. In order to make the drive system work normally, please meet the following several aspects requirements in installation:

✓ Field wiring

Power line supply electric independently from power transformer, five or four core line are generally used, null line and ground sharing a single line is forbidden.

Commonly signal wire (weak) and power wire (heavy) are in control cabinet, for the inverter, power wire is divided into input line and output line. Signal wire is easily interfered by power wire, so that causing the misoperation of the device. When wiring, signal wire and power wire should be distributed in different areas, parallel lines and interlaced lines are forbidden at close range(within 20cm), and especially don't bundle up the two lines. If the signal cables must pass via the power lines, the two should keep 90 degree angle. Interlace lines and banding together is also forbidden for the input and output line of power wire, especially on the occasions which noise filter is installed. It will cause the coupling of electromagnetic noise via the distributed capacitance of the input and output lines, thus the noise filter will out of action.

Generally a control cabinet has different electric equipment such as inverter, filter, PLC, measurement instrument, their ability of emitting and bearing electromagnetic noise are diverse from each other, and this requires classifying these equipment. The classification can be divided into strong noise equipment and noise sensitive equipment, Install the similar equipment in the same area and, and keep a distance more than 20cm among inhomogeneous equipment.

✓ Input noise filter, input and output magnet ring (Zero phase reactor)

Adding noise filter to the input terminal, the inverter will be isolated from the other equipment, and its ability of conduction and radiation will be reduced effectively. By adding winding ferrite bead to the input and output terminal and coordinating with internal filter, the inverters will have a better effect.

✓ Shielding

Good shielding and grounding can greatly reduce the interference of inverter, and can improve the anti-interference ability of the inverter. Sealing off the inverter with the good conductive sheet metal and connecting the sheet metal to ground, the radiation interference will be reduced effectively. To reduce the interference of inverter and improve the anti-interference ability, cable with shielding layer should be used in input and output and the both ends of it should be connected to ground. Shielding cable is suggested to be used in control connecting and communication connecting of the inverter external terminals under bad electromagnetic environment. Generally, the both ends of shielding layer should be connected to the control /communication ground, and they can also be connected to ground.

✓ Grounding

The inverter must be connected to the ground safely and reliably. Grounding is not only for equipment and personal safety, but also the simplest, the most efficient and the lowest cost method to solving the EMC problem, so it should be prioritized. Please refer to the section of "3.7 Terminal wiring".

✓ Carrier wave

The leakage current contains the leakage current from line to line or over the ground. It depends on the size of the distributed capacitance when wiring and the carrier frequency of the frequency. The higher the carrier frequency, the longer the motor cable, and the larger the cable cross-sectional area is, the larger the leakage current is. Reducing the carrier frequency can effectively reduce the leakage current. When the motor line is long (50m above), the output side should be installed with ac reactor or sine wave filter, when the motor line is longer, a reactor should be installed every other distance. At the same time, reducing carrier frequency can effectively reduce the conduction and radiation interference.

3.6 Peripheral devices

3.6.1 System Wire Arrangement

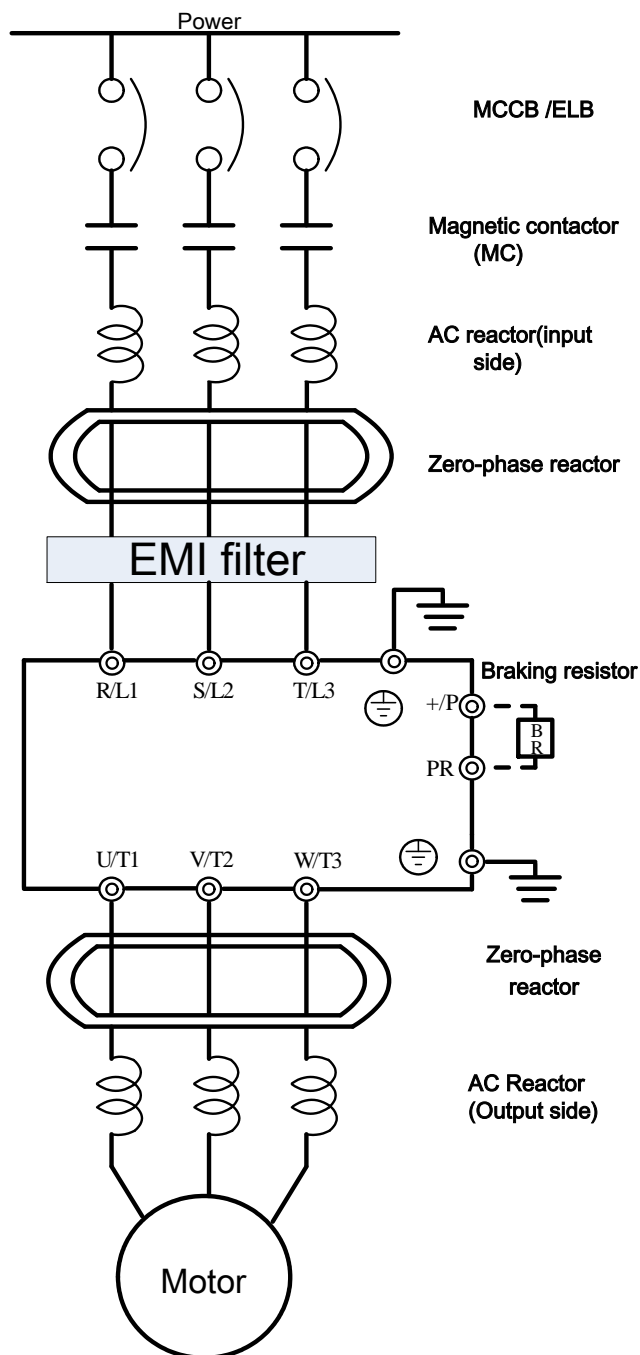

Power	please provide power specified in manual
Molded case circuit breaker (MCCB) or earth leakage current breaker (ELB)	When power ON there might be huge inrush current flows to inverter. Refer to chapter 3.6.2 for model selection.
Magnetic contactor (MC)	Do not use contactor to power on/off inverter. Doing so will shorten the life span of the inverter.
AC reactor(input side)	
Zero-phase reactor	It is recommend to install AC reactor to improve the power factor. The wire distance should be within 10 meters.
AC reactor(input side)	
Zero-phase reactor	Zero-phase reactors are used to reduce radio noise especially when audio equipment is installed near the inverter. Effective for noise reduction on both the input and output sides. The frequency band effective range is from AM to 10 MHz
EMI filter	Used to reduce electromagnetic interference
Braking unit	Used to reduce motor deceleration time
Output AC Line Reactor	Motor surge voltage amplitude depends on motor cable length. Recommend to install.

3.6.2 No-fuse breaker and magnetic contactor

Inverter model	Motor capacity	Power source capacity	Applicable no-fuse switch (NFB/MCCB) type (Shihlin Electric)	Applicable electromagnetic contactor (MC) type (Shihlin Electric)
SC3-043-0.4K	440V 0.5HP	1.5kVA	BM30SN3P3A	S-P11
SC3-043-0.75K	440V 1HP	2.5kVA	BM30SN3P5A	S-P11
SC3-043-1.5K	440V 2HP	4.5kVA	BM30SN3P10A	S-P11
SC3-043-2.2K	440V 3HP	6.9kVA	BM30SN3P15A	S-P21
SC3-043-3.7K	440V 5HP	10.4kVA	BM30SN3P20A	S-P21
SC3-043-5.5K	440V 7.5HP	13.8kVA	BM30SN3P30A	S-P21
SC3-043-7.5K/11KF	440V 10HP	16 kVA	BM30SN3P30A	S-P21
SC3-043-11K/15KF	440V 15HP	20 kVA	BM60SN3P50A	S-P30T
SC3-043-15K/18.5KF	440V 20HP	27 kVA	BM60SN3P60A	S-P40T
SC3-043-18.5K/22KF	440V 25HP	32 kVA	BM100SN3P75A	S-P40T
SC3-043-22K	440V 30HP	41 kVA	BM100SN3P100A	S-P50T
SC3-023-0.2K	220V 0.25HP	0.5kVA	BM30SN3P5A	S-P11
SC3-023-0.4K	220V 0.5HP	1.5kVA	BM30SN3P5A	S-P11
SC3-023-0.75K	220V 1HP	2.5kVA	BM30SN3P10A	S-P11
SC3-023-1.5K	220V 2HP	4.5kVA	BM30SN3P15A	S-P11
SC3-023-2.2K	220V 3HP	6.4kVA	BM30SN3P20A	S-P11 / S-P12
SC3-023-3.7K	220V 5HP	10kVA	BM30SN3P30A	S-P21
SC3-021-0.2K	220V 0.25HP	0.5 kVA	BM30SN3P5A	S-P11
SC3-021-0.4K	220V 0.5HP	1.5kVA	BM30SN3P5A	S-P11
SC3-021-0.75K	220V 1HP	2.5kVA	BM30SN3P10A	S-P11
SC3-021-1.5K	220V 2HP	3.5kVA	BM30SN3P15A	S-P11
SC3-021-2.2K	220V 3HP	6.4kVA	BM30SN3P20A	S-P11/ S-P12

3.6.3 Regeneration brake resistor

Voltage	Applicable motor (kW)	brake resistor (10%ED , 125%braking torque)	Max. braking torque limit		
		Equivalent resistor specs	Min. resistance (Ω)	Max. braking current (A)	Max. peak power (kW)
021	1.5	150W 100Ω	60	6	2.2
	2.2	220W 68.2Ω	60	6	2.2
023	2.2	220W 68.2Ω	60	6	2.2
	3.7	370W 40.5Ω	40	9	3.2
043	2.2	220W 272.8Ω	160	5	3.2
	3.7	370W 162.2Ω	120	6	4.3
	5.5	550W 109.1Ω	75	10	6.9
	7.5	750W 80Ω	75	10	6.9
	11	1100W 54.6Ω	50	14	10.4
	15	1500W 40Ω	40	18	13.0
	18.5	1850W 32.4Ω	32	23	16.2
22	2200W 27.3Ω	27.2	26	19.1	

Note:1. The duty of brake resistors for built-in braking unit is based on 10% regenerative brake duty (when used for 5 seconds, the machine has to be stopped for another 45 seconds for heat dissipation). For models without a built-in brake unit, the duty of brake resistors is based on the brake duty of the selected external brake unit. The regenerative brake resistor wattage can be reduced according to the user's application (quantity of heat) and the regenerative brake duty. But the resistance must be larger than or equal to the value (ohms) listed in the above table (otherwise the inverter will be damaged).

2. In case frequent start and stop operations are required, a larger regenerative brake duty should be set. Meanwhile, a large brake resistor should be used correspondingly. Please feel free to contact us if there is any problem regarding the selection of brake resistors.

To prevent the braking resistor from overheating or burning out when the brake unit is damaged, it is recommended to use the sequence control program shown in the figure below.

Example 1 :

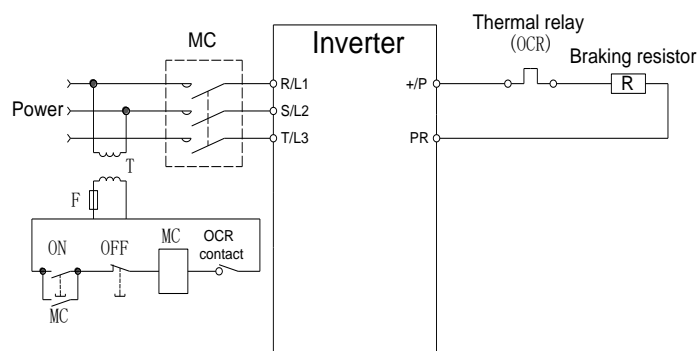

Example 2 :

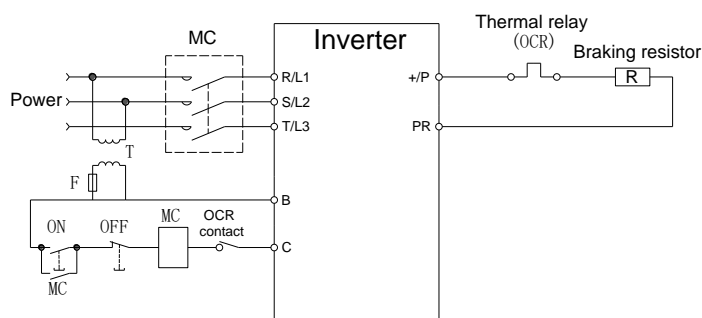

3.7 Terminal wire arrangement

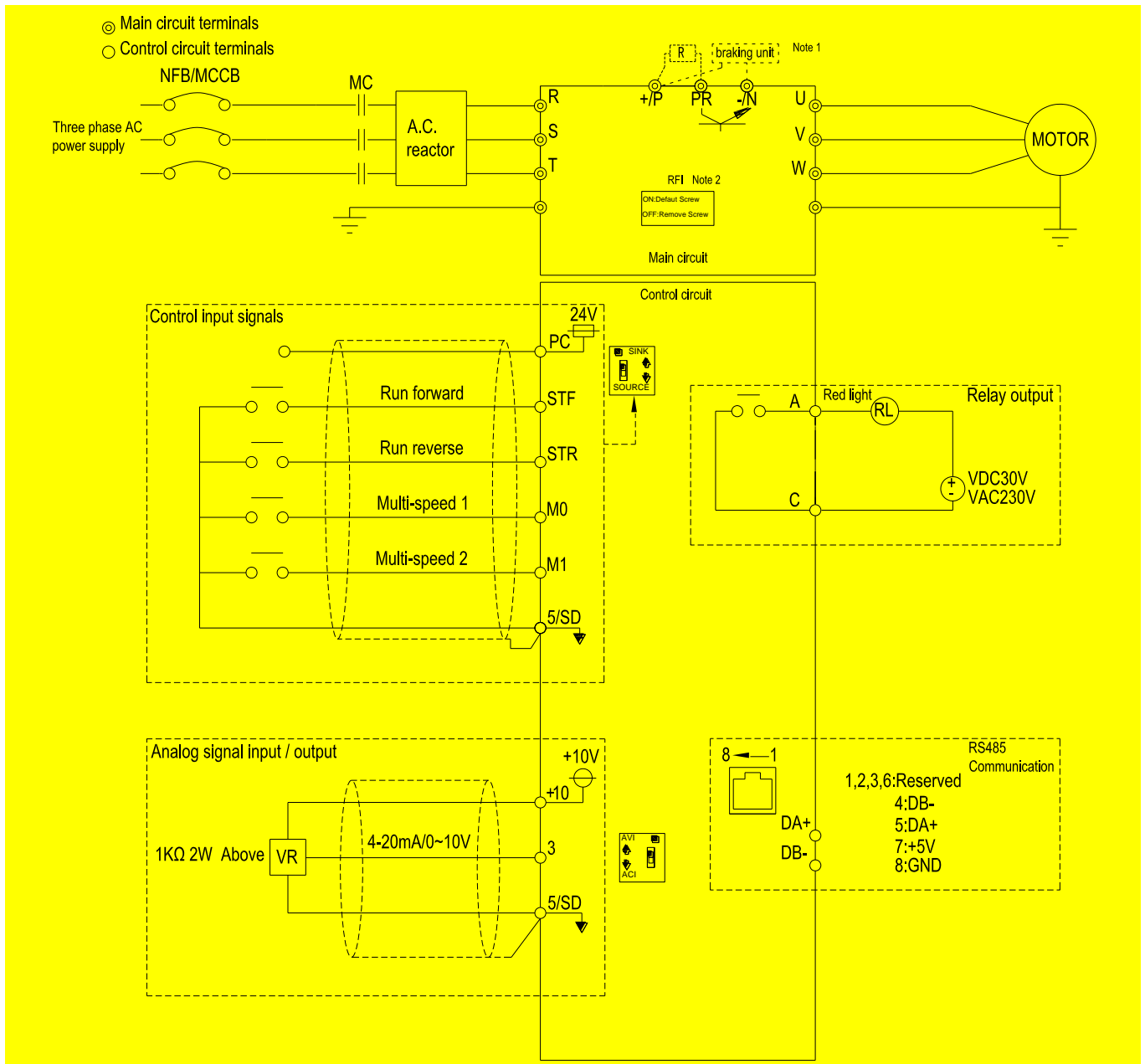

Note: 1. SC3-043-0.4K~1.5K , SC3-023-0.2K~1.5K , SC3-021-0.2K~0.75K without +P , PR and N terminals;
 SC3-043-2.2K~5.5K , SC3-023-2.2K~3.7K , SC3-021-1.5K~2.2K without N terminals.

2.All series includes built-in RFI filters, in order to comply with CE regulations, please refer to related parts in this manual .

3.7.1 Main circuit Terminals

✓ Description

Main circuit terminals description	
R/L1-S/L2-T/L3	Connect to commercial power supply
U/T1-V/T2-W/T3	Connect to three-phase induction motor.
(+P)-PR	Connect to braking resistor (frame B built-in braking unit)
	Connect to ground

Note: There's no "+P" and "PR" terminals in Frame A (no built-in braking unit).

✓ Terminal layout of the main circuit terminals

• Frame A

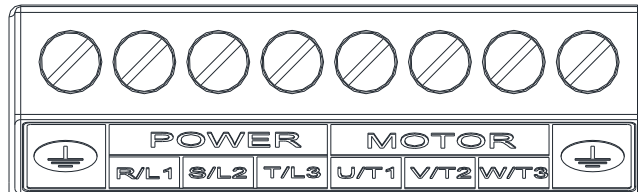

• Frame B

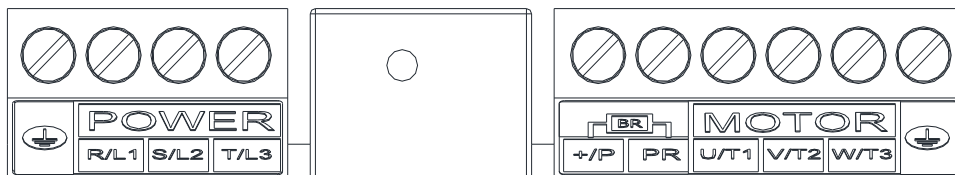

• Frame C

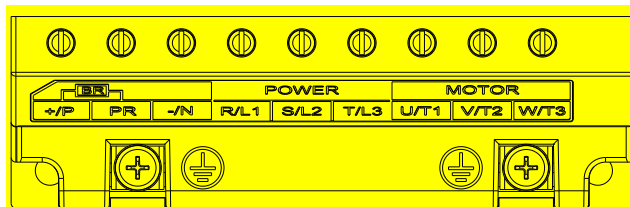

• Frame D

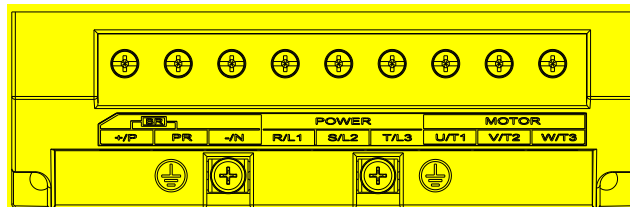

✓ Connect to braking resistor

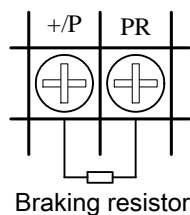

Note: There is built-in braking unit in frame B, which can be equipped with braking resistor. Please refer to Section 3.3 Appearance and dimensions for the description of the frame.

3.7.2 Main circuit wiring and terminal specification

Inverter model	Terminal screw specifications	Tightening torque (Kgf.cm)	Recommended wiring specification(mm ²)				Recommended wiring specification (AWG)			
			R, S, T	U, V, W	+P, PR	Grounding Cable	R, S, T	U, V, W	+P, PR	Grounding Cable
SC3-021-0.2K	M3	4~6	2.5	1.5	---	1.5	14	16	---	16
SC3-023-0.2K			1.5	1.5	---	1.5	16	16	---	16
SC3-043-0.4K			1.5	1.5	---	1.5	16	16	---	16
SC3-021-0.4K			2.5	2.5	---	2.5	14	14	---	14
SC3-023-0.4K			2.5	2.5	---	2.5	14	14	---	14
SC3-043-0.75K			2.5	2.5	---	2.5	14	14	---	14
SC3-021-0.75K			2.5	2.5	---	2.5	14	14	---	14
SC3-023-0.75K			2.5	2.5	---	2.5	14	14	---	14
SC3-043-1.5K			2.5	2.5	---	2.5	14	14	---	14
SC3-023-1.5K			2.5	2.5	---	2.5	14	14	---	14
SC3-021-1.5K			2.5	2.5	2.5	2.5	14	14	14	14
SC3-043-2.2K			2.5	2.5	2.5	2.5	14	14	14	14
SC3-021-2.2K			4	4	4	4	12	12	12	12
SC3-023-2.2K			4	4	4	4	12	12	12	12
SC3-043-3.7K			2.5	2.5	2.5	2.5	10	14	14	14
SC3-043-5.5K			2.5	2.5	2.5	2.5	14	14	14	14
SC3-023-3.7K			4	4	4	4	12	12	12	12
SC3-043-7.5K/11KF			M4	9.5~10.5	6	6	6	6	10	10
SC3-043-11K/15KF	M4	9.5~10.5	10	10	10	10	8	8	8	
SC3-043-15K/18.5KF	M5	19~20	10	10	10	10	8	8	8	8
SC3-043-18.5K/22KF			16	16	16	16	6	6	6	6
SC3-043-22K			25	25	25	25	4	4	4	4

- Note:1. Do not connect power wire to motor terminals (U/T1)(V/T2)(W/T3) on inverter, otherwise it will cause damage.
2. Do not add phase capacitor, surge absorber or magnetic contactor on the output side of the inverter.

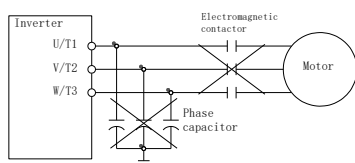

3. Do not use "magnetic contactor" or "no fuse switch" to start and stop the motor.
4. Please do grounding for the inverter and motor to avoid electric shock.
5. For specifications of no-fuse breaker and magnetic contactor, please refer to section 3.6.2.
6. If the distance between the inverter and motor is long, please use thick wires, make sure wire voltage drop is under 2V (wire length below 500 meters).
7. Use "insulation crimp sleeve " for power supply side and load side connection.
8. After the power is cut off, there is still high voltage between the terminals of the main circuit within a short period of time. Please do not touch the terminals within 10 minutes to avoid electric shock.

3.7.3 Ground

For safety and to reduce noise, the grounding \oplus of the inverter must be well grounded. To avoid electric shocks and fire accident, the external metal ground wire of the equipment should be short and thick, and should be connected to specific grounding terminals on the inverter. If several inverters are placed together, all inverters must be connected to the common ground. Please refer to the following diagrams and ensure that no loop is formed between grounding terminals.

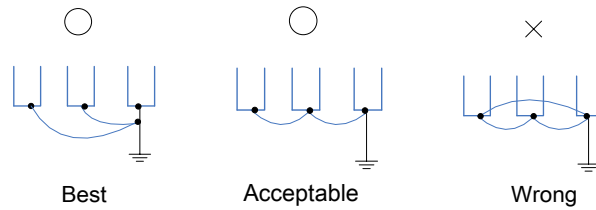

3.7.4 RFI filter

SC3 series inverters are equipped with built-in RFI filters. These filters are effective in reducing electromagnetic interference, but to meet CE standard, please refer to section 3.5.4 for installation and wiring.

✓ Frame A/B

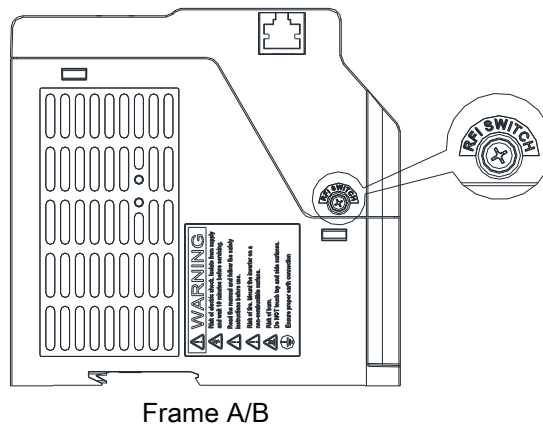

✓ Frame C/D

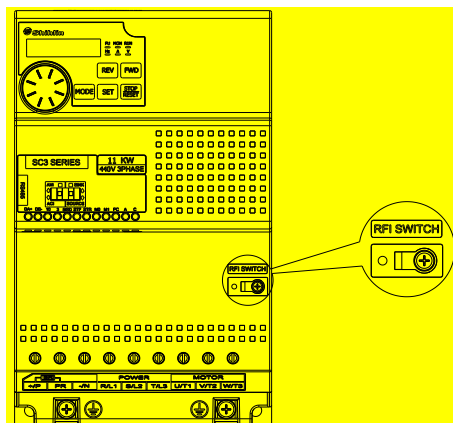

RFI filter ON : Screw lock (Default)

RFI filter OFF : Screw out

Frame	Screw used	Tightened torque
A	M3*10	2.5kgf.cm
B	M3*14	2.5kgf.cm

3.7.5 Control circuit

✓ Control terminal name

Terminal type	Terminal name	Function instructions	Terminal specifications
Digital signal input	STF	These 4 are multi-function control terminals, can switch between SINK/SOURCE.	Input impedance:4.7 kΩ Action current :5mA(when 24VDC) Voltage range:10~28VDC Maximum frequency : 1kHz
	STR		
	M0		
	M1		
Analog signal input	10	+10.5±0.5V	Maximum current:10mA
	3	0~10V/4~20mA	Input impedance:10kΩ
Relay output	A	Multi-function relay output terminals. A-C is normal open contact, C is common terminal.	Maximum voltage:30VDC or 250VAC Maximum current: Resistor load 5A NO/3A NC Inductance load 2A NO/1.2A NC (cosΦ=0.4)
	C		
Communication terminal	RJ45	RS485, optical coupling isolation RJ45 and "DA+/DB-" won't work at the same time	Highest rate:115200bps Longest distance:500m
	DA+		
	DB-		
Common terminal	5/SD	COM terminal for STF, STR, M0, M1,3 (SINK)	---
	PC	COM terminal for STF, STR, M0, M1 (SOURCE)	---

✓ Switching SINK/SOURCE control logic

The multi-function digital input terminals on SC3 series inverter can be switched between sink and source by the toggle switch. The diagram is as follows:

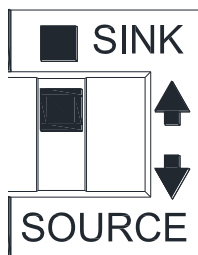

No matter which mode the multi-function digital input terminal is in, all of them can be considered as a simple switch. If the switch is "┌ on ┘," the control signal will be apply into the terminal. If the switch is "└ off ┘," the control signal is shut off.

If "Sink Input" mode is selected, when the multi-function digital input terminal is short-circuited to SD or connected to an external PLC, the function of this terminal is valid. In this mode, the current flows from the corresponding terminal when it is short. Terminal "SD" is common terminal of the contact input signals. When the output transistor is powered by an external power supply, use PC terminal as a common terminal to prevent malfunction due to leakage current.

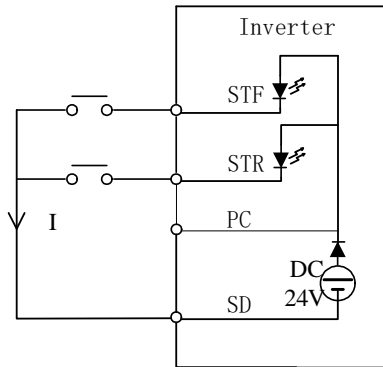

Sink input: Digital input control terminal connect to SD directly

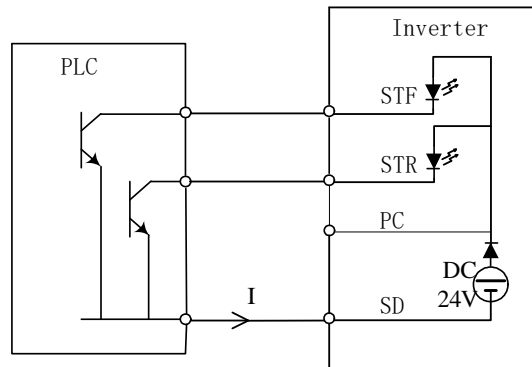

Sink input: Digital input control terminal connect to open collector PLC directly

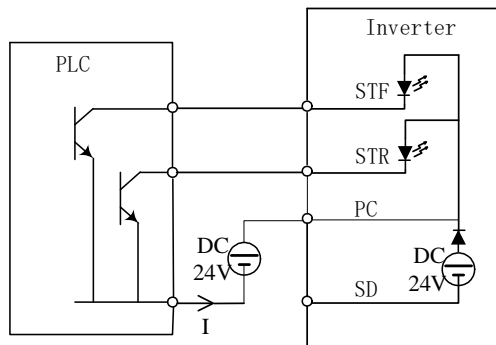

Sink input: Digital input control terminal connect to open collector PLC with exterior power supply

If "Source Input" mode is selected, when the multi-function digital input terminal is short-circuited to PC or connected to an external PLC, the function of this terminal is valid. In this mode, the current flows into the corresponding terminal when it is short. Terminal "PC" is common terminal of the contact input signals. When the output transistor is powered by an external power supply, use SD terminal as a common terminal to prevent malfunction due to leakage current.

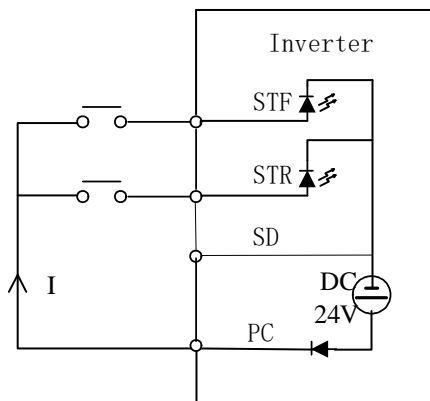

Source Input: Digital input control terminal connect to PC directly

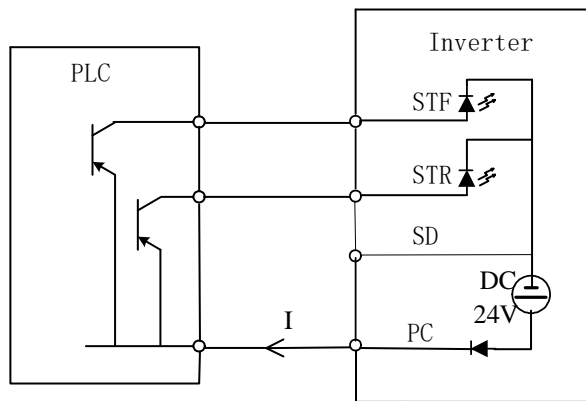

Source Input: Digital input control terminal connect to open emitter PLC directly

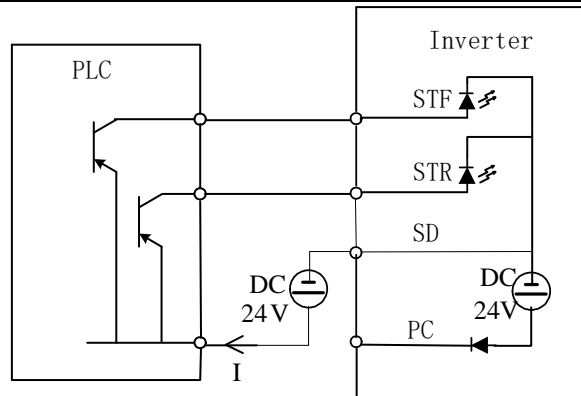

Source Input: Digital input control terminal connect to open emitter PLC with exterior power supply

✓ Arrangement of control terminal

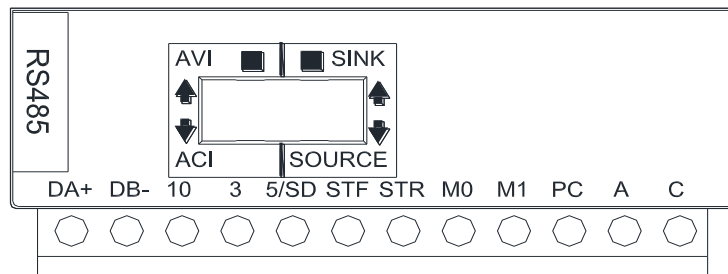

● Wires connection

For the control circuit wiring, strip off the sheath of a cable, and use it with a blade terminal. For a single wire, strip off the sheath of the wire and apply directly.

(1) Strip off the sheath for the below length. If the length of the sheath peeled is too long, a short circuit may occur with neighboring wires. If the length is too short, wires might come off. Wires should be well connected to avoid messiness. In addition, don't need to solder it.



(2) Insert the wire to blade terminal and crimping.

Insert wires to a blade terminal, and check that the wires come out for about 0 to 0.5 mm from a sleeve.

Check the condition of the blade terminal after crimping. Do not use a blade terminal of which the crimping is inappropriate, or the face is damaged.

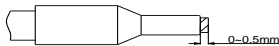

● Please do use blade terminals with insulation sleeve. Blade terminals commercially available:

Cable gauge (mm ²)	Blade terminals model	L (mm)	d1 (mm)	d2 (mm)	Manufacturer	Crimping tool product number
0.3	AI 0,25-6 WH	10.5	0.8	2	Phoenix Contact Co., Ltd.	CRIMPFOX 6
0.5	AI 0,5-6 WH	12	1.1	2.5		
0.75	AI 0,75-6 GY	12	1.3	2.8		
0.75 (for two wires)	AI-TWIN 2×0,75-6 GY	12	1.3	2.8		

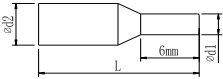

- Note: 1. Please Use a small flathead screwdriver (tip thickness: 0.6mm, width: 3.0mm). If a flathead screwdriver with a narrow tip is used, terminal block maybe damaged.
2. Tightening torque is 3.2~4.8 kgf.cm, too large tightening torque can cause screw slippage, too little tightening torque can cause a short circuit or malfunction.

✓ Toggle switch

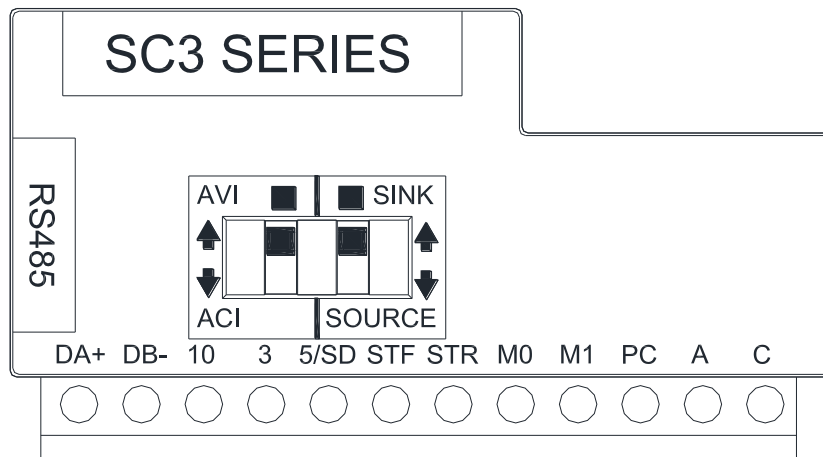

Switch number	Switch state	Explanation	Remarks
SINK/SOURCE	*	Selects Sink Input	Refer to chapter 3.7.5 Switching SINK/SOURCE control logic
		Selects Source Input	
AVI/ACI	*	Input 4~20mA current signal into terminal 3	Also requires setting 02-20(P.17),refer to chapter 5.3.3
		Input 0~10V voltage signal into terminal 3	

- Note: 1. The state with “ * ” mark is the default state.
2. Black part represents the toggle switch handle.

3.8 Replacement procedure of fan

3.8.1 Frame A/B

1. Press the hooks on both sides of the fan cover to remove the fan cover, as shown in the figure below.

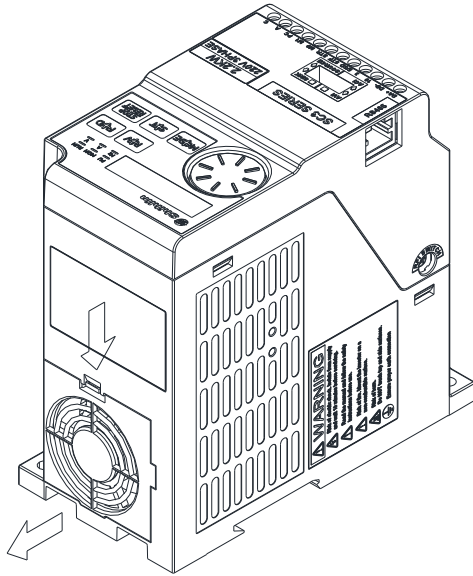

2. After disconnecting the fan connector, take out the fan, as shown in the figure below.

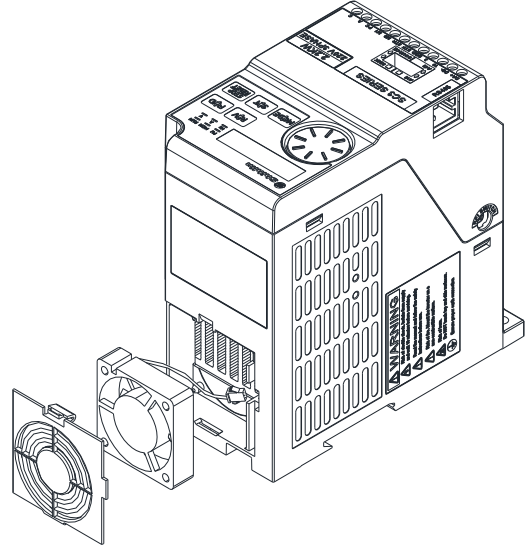

3.8.2 Frame C/D

1. Press the hooks on both sides of the fan cover to remove the fan cover, as shown in the figure below.

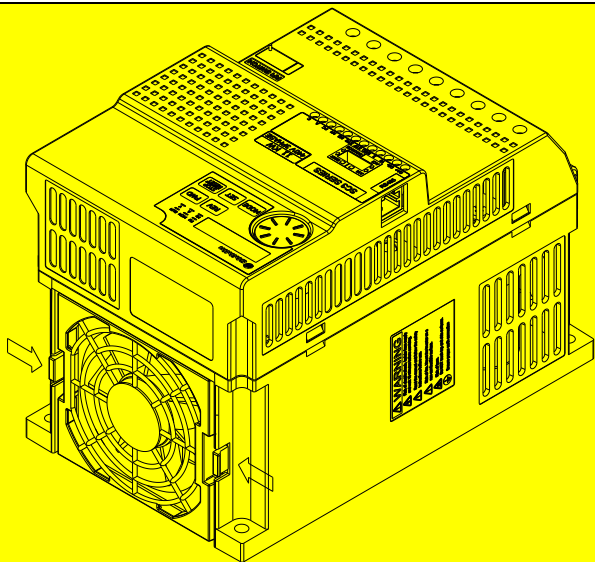

2. After disconnecting the fan connector, take out the fan, as shown in the figure below.

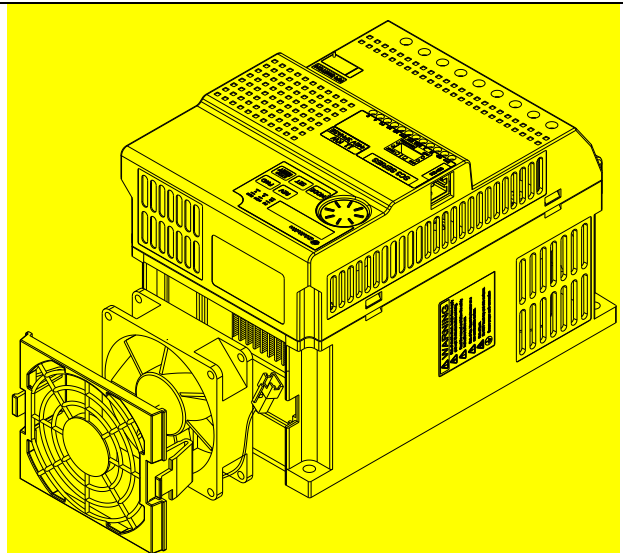

4. BASIC OPERATION



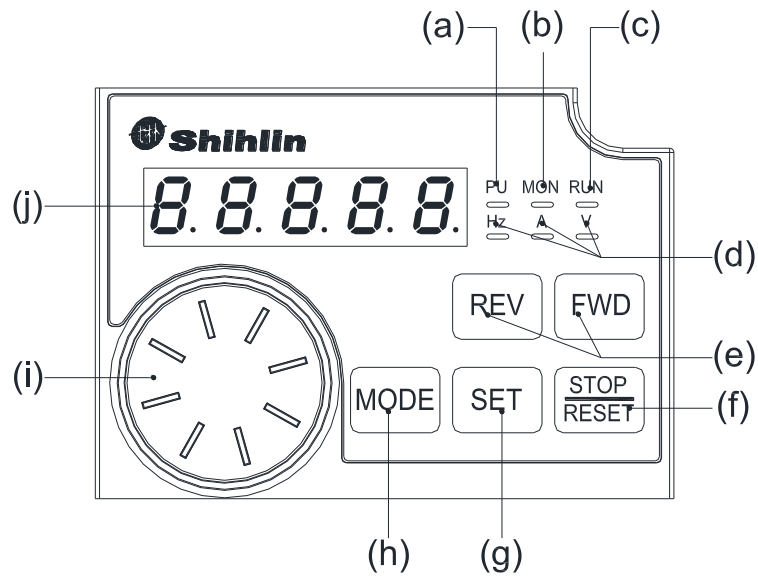



4.1 Component name of keypad



NO.	Operation parts	Name	Content
(a)	PU —	Operation mode indicator	PU: On when in PU/JOG operation mode, flickers in H1~H5 operation mode.
(b)	MON —	Keypad status indicator	MON : On to indicate keypad is in monitoring mode
(c)	RUN —	RUN indicator	Flickers when running.
(d)	Hz A V — — —	Unit for the monitoring value	Hz: On when monitoring frequency. A: On when monitoring output current. V: On when monitoring optional values (output voltage by default). Can be set by 00-07 (P.161) to monitor different values.
(e)	FWD REV	FWD button REV button	FWD: Forward rotation start, RUN light is on during forward rotation. REV: Reverse rotation start, RUN light is on during reverse operation.
(f)	STOP RESET	STOP/RESET button	Stop command. Reset the inverter when alarm.
(g)	SET	SET button	Long press this key to write parameter values, frequency, etc. Short press this key to read the parameter value. Enter the next menu.
(h)	MODE	MODE button	Switch between different modes.
(i)		M setting dial	Clockwise rotation equals to a UP button. Counter clockwise rotation equals to a DOWN button
(j)	8.8.8.8.8	Monitor (5-digit LED)	Shows the frequency, parameter number, and parameter value, etc.

4.2 Operation modes of inverter

- Operation modes are related to signal source for the target frequency and signal source for motor starting. In Shihlin SC3 inverter there are nine kinds of operation modes: "PU mode (PU)", "JOG mode (JOG)", "External mode (Ext)", "Communication mode (CU)", "Combined mode 1 ($H1$)", "Combined mode 2 ($H2$)", "Combined mode 3 ($H3$)", "Combined mode 4 ($H4$)", "Combined mode 5 ($H5$)".
- Users can use the built-in keypad to monitor output frequency, monitor output voltage, monitor output current, browse alarm messages, parameter settings, and frequency settings. There are 5 working modes in the built-in keypad: "Operation Mode", "Monitoring Mode", "Frequency Setting Mode", "Parameter Setting Mode", and "HELP Mode".

Related parameters	Value	Operation mode	Signal source for target frequency	Signal source for motor starting	Remarks
Operation mode selection 00-16(P.79)	0	PU mode (PU)	Built-in keypad	 or  button on built-in keypad	"PU mode", "JOG mode" and "external mode" are interchangeable.
		JOG mode (JOG)	Value set in parameter 01-13(P.15)	 or  button on built-in keypad	
		External mode (Ext)	"External voltage/current signal", "multi-speed terminal" and external JOG signal (01-13(P.15)) Frequency of each section in the programmed operation mode 04-19~04-26 / P.131~P.138	External STF/STR terminals External STF terminal	
	1	PU mode (PU)	Equals to 00-16(P.79) = 0 when 00-16(P.79) = 0		"PU mode" and "JOG mode" are interchangeable.
		JOG mode (JOG)	Equals to "JOG mode" when 00-16(P.79) = 0		
	2	External mode (Ext)	Equals to "External mode" when 00-16(P.79) = 0		
	3	Communication mode (CU)	Communication	Communication	
	4	Combined mode 1 ($H1$)	Built-in keypad	External STF/STR terminals	
	5	Combined mode 2 ($H2$)	External voltage / current signal, multi-speed terminal	 or  button on built-in keypad	
	6	Combined mode 3 ($H3$)	Communication, multi-speed terminal and external JOG (01-13(P.15))	External STF/STR terminals	
7	Combined mode 4 ($H4$)	External voltage / current signal, multi-speed terminal	Communication		
8	Combined mode 5 ($H5$)	Communication, multi-speed terminal and external JOG (01-13(P.15))	External STF/STR terminals		

- When 00-16(P.79) = 0, the external mode (Ext) is the default mode after inverter is turned on. Use 00-16(P.79) to switch the operation mode.

4.2.1 Flow chart for switching operation mode

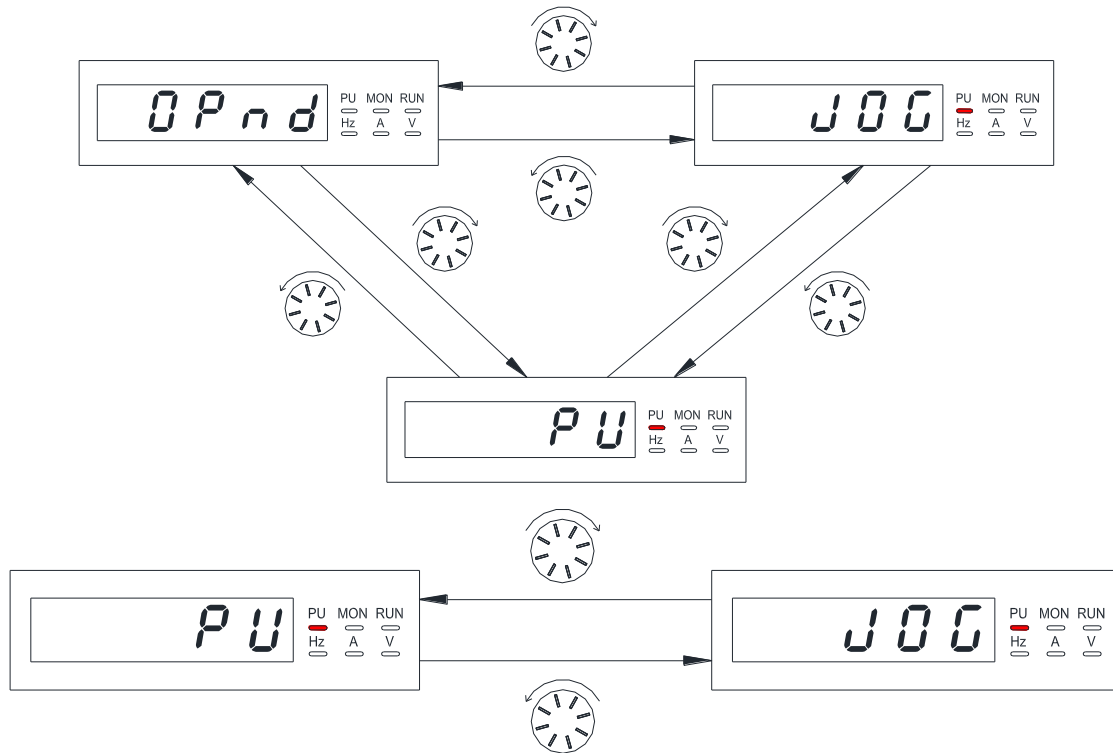

- Note: 1. In "PU mode", keypad screen displays *PU* and the indicator in **PU** will light up.
2. In "External mode", keypad screen displays *OPnd*.
3. In "Combined mode 1, 2, 3, 4, or 5", the indicator in **PU** will flicker.
4. In "JOG mode", the indicator in **PU** will light up, and show *JOG* when motor is not running.
5. No flow chart when 00-16(P.79) is set to =2, 3, 4, 5, 6, 7 or 8 since the operation mode will not switch.

4.2.2 Flow chart for switching built-in keypad working mode

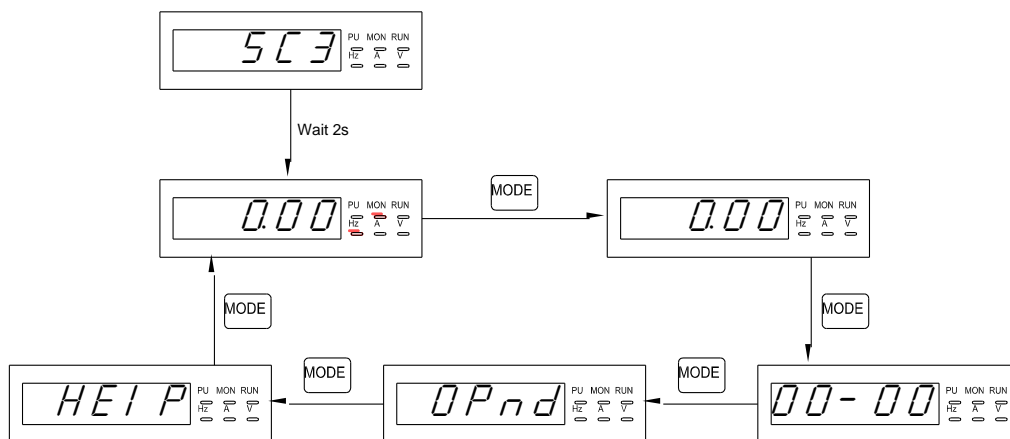

- Note: 1. Please refer to section 4.2.3 for detailed operation steps under monitoring mode.
2. Please refer to section 4.2.4 for detailed operation steps under frequency setting mode.
3. Please refer to section 4.2.5 for detailed operation steps under parameter setting mode.
4. Please refer to Section 4.2.1 for detailed operation steps under switching operation mode.
5. Please refer to Section 4.2.6 for detailed operation steps under HELP mode.

4.2.3 Operation flow chart for monitoring mode

•Take PU mode as an example :

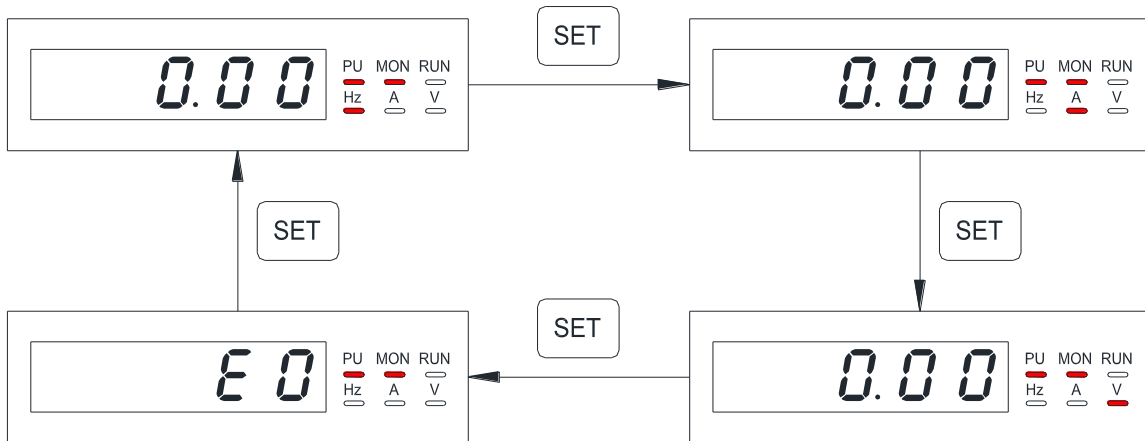

- Note: 1. In “monitoring output frequency” mode, indicator in **MON** and **Hz** will light up, and the screen will display current output frequency.
2. In “monitoring optional value” mode, indicator in **MON** and **V** will light up, and the screen will display current optional value. The optional value is chosen by parameter 00-07(P.161), the default setting is monitor output voltage.
3. In “monitoring output current” mode, indicator in **MON** and **A** will light up, and the screen will display current output current.
4. When in “browsing alarm record” mode, indicator in **MON** will light up, and the screen will display current alarm code.
5. For alarm codes, please refer to Appendix 2.

4.2.4 Operation flow chart for frequency setting

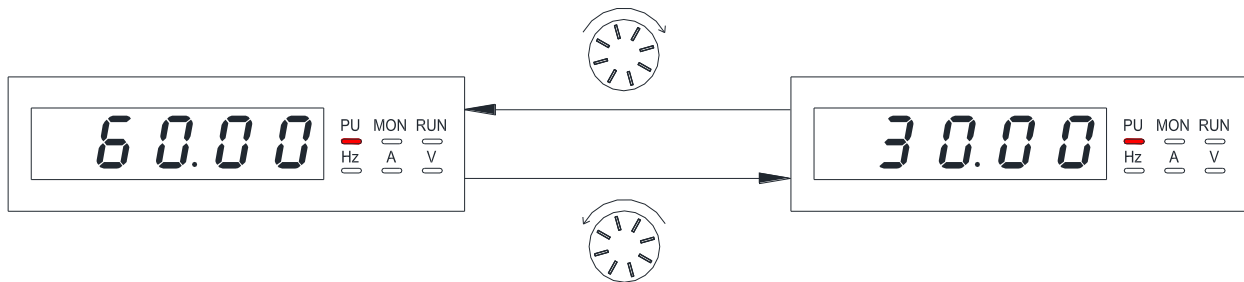

- Note: 1. Use dial to change the frequency when the inverter is running.
2. Under frequency setting mode, indicator in **Hz** and **MON** will not light up.
3. When setting frequency with keypad, the set value cannot exceed the upper frequency. When high frequency is needed, the upper frequency should be changed first.

4.2.5 Operation flow chart for parameter setting

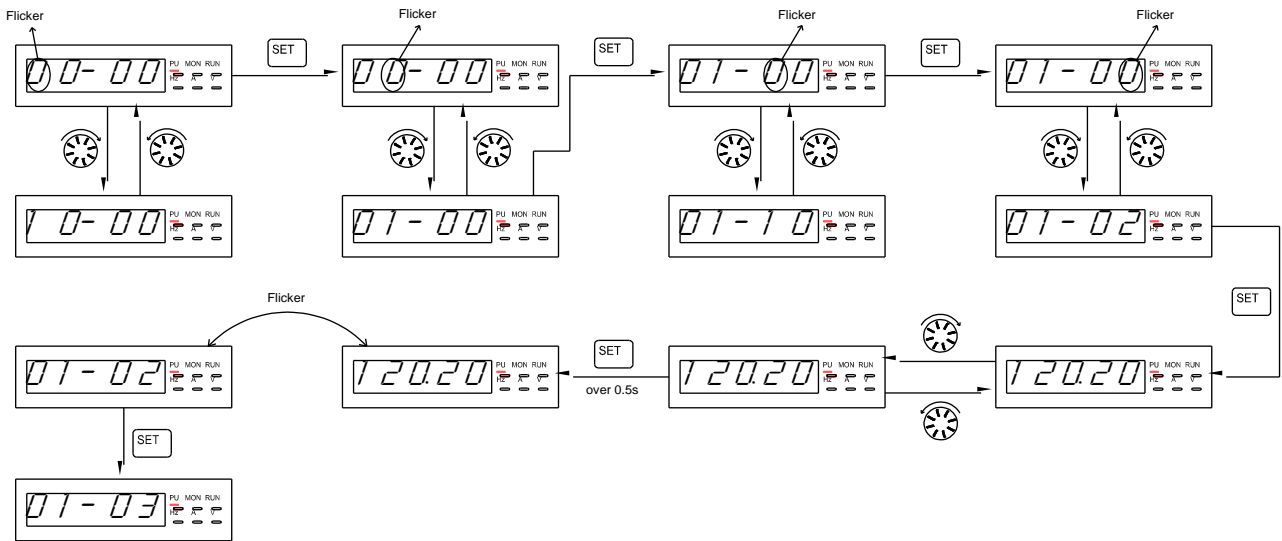

Note: Indicator in **Hz** and **MON** will NOT light up under parameter setting mode. Be sure to hold **SET** key and keep it above 0.5s.

4.2.6 Operation flow chart for HELP mode

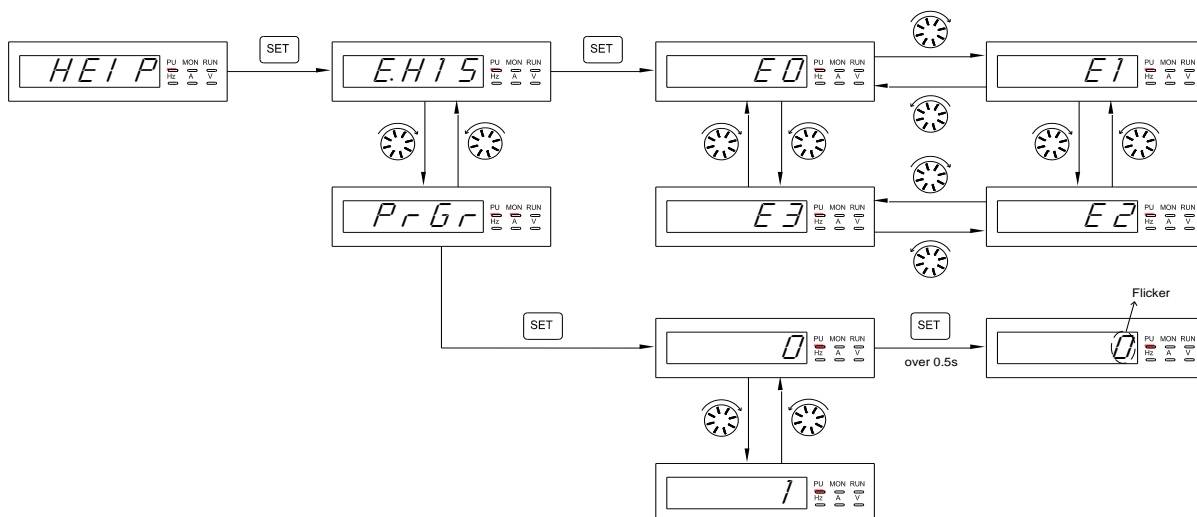

Note: 1. When browsing alarm record, the screen will display 4 most recent alarm codes.
 2. For alarm codes, please refer to Appendix 2.

4.3 Basic operation steps for different modes

4.3.1 Basic operation steps for PU mode (00-16(P.79) = 0 or 1)

Step	Description
1	<ul style="list-style-type: none"> Switch operation mode to PU mode, and indicator in PU will light up. <p>Note: 1. When 00-16(P.79) =0, the inverter will first be in external mode after power on or reset. 2. For selecting and switching operation mode, please refer to section 4.2.</p>
2	<ul style="list-style-type: none"> Enter frequency setting mode and write target frequency into memory. <p>Note: For detailed setting procedures, please refer to section 4.2.4.</p>
3	<ul style="list-style-type: none"> Press FWD or REV to run the motor. At this point, indicator RUN will flicker to indicate that the motor is running. The keypad will automatically switch to monitor mode and display the current monitor item. <p>Note: 1. For detailed operation steps for monitoring mode, please refer to section 4.2.3. 2. While the motor is running, the user can enter frequency setting mode to change target frequency for regulating the motor speed.</p>
4	<ul style="list-style-type: none"> Press STOP/RESET and the motor will begin to decelerate until it comes to a full stop. Indicator in RUN will not turn off until the inverter stops outputting voltage.

4.3.2 Basic operation steps for external mode (00-16(P.79) = 0 or 2)

Step	Description
1	<ul style="list-style-type: none"> Switch operation mode to External mode, screen will display <i>Opnd</i>. <p>Note: 1. When 00-16(P.79) =0, after power on or reset, press MODE to switch to operation mode, inverter will first switch to external mode, then use dial on keypad to switch to PU mode; 2. When 00-16(P.79) =2, inverter will always be in external mode ; 3. For selecting and switching operation mode, please refer to section 4.2.</p>
2	<ul style="list-style-type: none"> Target frequency is set by external terminals (default priority from high to low): If program operating mode is chosen, please refer to section 5.4.1 function selection of digital input and 5.5.2 programmed operation mode. If target frequency is set by multi-speed stage levels, please refer to section 5.5.1 16 step speed. If target frequency is set by input signal across terminal 3-5, please refer to section 5.3.3 terminal 3-5 signal selection and processing .
3	<ul style="list-style-type: none"> Turn on STF or STR to run the motor. At this point, indicator in RUN will flicker, indicating that the motor is running. <p>Note: 1. For setting up the starting terminals STF and STR, please refer to section 5.1.8 stop operation selection and 5.4.1 function selection of digital input. 2. For detailed operation steps for the monitor mode, please refer to section 4.2.3 Operation flow chart for monitoring mode. 3. If programmed operation mode is chosen, then STF and STR will become the starting signal and the pause signal, instead of being forward or reverse terminals.</p>
4	<ul style="list-style-type: none"> Turn off STF or STR to decelerate the motor until it comes to a full stop. Indicator in RUN will not turn off until the inverter stops outputting voltage.

4.3.3 Basic operation steps for JOG mode (00-16(P.79) = 0 or 1)

Step	Description
1	<ul style="list-style-type: none"> Switch operation mode to JOG mode and indicator in PU will light up, the display shows U00. <p>Note: 1. For detailed operating procedures for the monitor mode, please refer to section 4.2 Operation modes of inverter.</p>
2	<ul style="list-style-type: none"> Press FWD or REV to run the motor. At this point, indicator in RUN will flicker, indicating that the motor is running. Release FWD or REV to decelerate the motor until it comes to a full stop. Indicator in RUN will not turn off until the inverter stops the output. <p>Note: 1. For detailed operating procedures for monitor mode, please refer to section 4.2.3.</p> <p>2. In JOG mode, target frequency is the value of 01-13(P.15), and the acceleration / deceleration time is the value of 01-14(P.16). Please refer to section 5.2.7 JOG operation.</p>

4.3.4 Basic operation steps for communication mode (00-16(P.79) = 3)

- ◆ In communication mode, user can set parameters and run/stop or reset inverters by communication. Please refer to [Communication function related parameters](#) for details.

4.3.5 Basic operation steps for combined mode 1 (00-16(P.79) = 4)

Step	Description
1	<ul style="list-style-type: none"> In Combined Mode 1, indicator PU will light up. <p>Note: 1. For detailed operation procedures for monitor mode, please refer to section 4.2.</p>
2	<ul style="list-style-type: none"> Enter frequency setting mode and write target frequency into memory. <p>Note: For setting details, please refer to section 4.2.4.</p>
3	<ul style="list-style-type: none"> Set target frequency by built-in keypad and start the inverter by terminal STF/STR . At this point, indicator in RUN will flicker, indicating that the motor is running. <p>Note: For detailed operation procedures for monitor mode, please refer to section 4.2.3.</p>
4	<ul style="list-style-type: none"> When terminal STF/STR signals turn off, motor will decelerate until it comes to a full stop. Indicator in RUN will not turn off until the inverter stops outputting.

4.3.6 Basic operation steps for combined mode 2 (00-16(P.79) = 5)

Step	Description
1	<ul style="list-style-type: none"> In Combined Mode 2, indicator in PU will light up. <p>Note: For selecting and switching the operation mode, please refer to section 4.2 Operation modes of inverter.</p>
2	<ul style="list-style-type: none"> Target frequency is set by external terminals (default priority from high to low): If the programmable operating mode is chosen, please refer to section 5.4.1 function selection of digital input and 5.5.2 programmed operation mode. If target frequency is set by multi-speed stage levels, please refer to section 5.5.1 16 step speed. If target frequency is set by input signal across terminal 3-5, please refer to section 5.3.3 terminal 3-5 signal selection and processing.
3	<ul style="list-style-type: none"> Press REV or FWD to run the motor. At this point, indicator RUN will flicker to indicate that the motor is running. <p>Note: 1. For detailed operation steps for monitoring mode, please refer to section 4.2.3. 2. While the motor is running, the user can enter frequency setting mode to change target frequency for regulating the motor speed.</p>
4	<ul style="list-style-type: none"> Press STOP/RESET and the motor will begin to decelerate until it comes to a full stop. Indicator in RUN will not turn off until the inverter stops outputting voltage.

4.3.7 Basic operation steps for combined mode 3(00-16(P.79) = 6)

Step	Description
1	<ul style="list-style-type: none"> In Combined Mode 3, indicator in PU will flicker. <p>Note: 1. For detailed operation procedures for monitor mode, please refer to section 4.2.</p>
2	<p>Default priority from high to low :</p> <ul style="list-style-type: none"> When external JOG is "on", target frequency is determined by 01-13(P.15). Acceleration / deceleration time is set by the value of 01-14(P.16). When RL, RM, RH and REX of multi-speed stage levels are "on", target frequency is determined by combination of multi-speed stage levels, please refer to section 5.5.1 16 step speed. Target frequency is set by communication.
3	<ul style="list-style-type: none"> Give STF/STR signal to run the motor. At this point, indicator RUN will flicker to indicate that the motor is running. Functions of 00-02 (P.996~P.999) can be accomplished by communication. <p>Note: For detailed operation procedures for the monitor mode, please refer to Section 4.2.3.</p>
4	<ul style="list-style-type: none"> When terminal STF/STR signals turn off, motor will decelerate until it comes to a full stop. Indicator in RUN will not turn off until the inverter stops outputting.

4.3.8 Basic operation steps for combined mode 4(00-16(P.79) = 7)

Step	Description
1	<ul style="list-style-type: none"> In Combined Mode 4, indicator in PU will flicker. <p>Note: 1. For detailed operation procedures for monitor mode, please refer to Section 4.2.</p>
2	<p>Default priority from high to low :</p> <ul style="list-style-type: none"> If target frequency is set by multi-speed stage levels, please refer to section 5.5.1 16 step speed. If target frequency is set by input signal across terminal 3-5, please refer to section 5.3.3 terminal 3-5 signal selection and processing .
3	<ul style="list-style-type: none"> Inverter is start by communication (including "Reset"). At this point, indicator RUN will flicker indicating that the motor is running. <p>Note: 1. For detailed operation procedures for the monitoring mode, please refer to Section 4.2.3.</p> <p>2. While the motor is running, the user can enter into the frequency setting mode to change the target frequency for regulating the motor speed.</p>
4	<ul style="list-style-type: none"> When communication sends the stop command, motor will decelerate until it comes to a full stop. Indicator in RUN will not turn off until the inverter stops output.

4.3.9 Basic operation steps for combined mode 5(00-16(P.79) = 8)

Step	Description
1	<ul style="list-style-type: none"> In Combined Mode 5, indicator PU will light up. <p>Note: For detailed operating procedures for monitor mode, please refer to Section 4.2.</p>
2	<ul style="list-style-type: none"> Target frequency of the inverter is set by keypad: When RL, RM, RH and REX for multi-speed stage levels are "on", target frequency is determined by the combination of multi-speed stage levels , please refer to section 5.5.1 16 step speed. When external JOG is "on", target frequency is determined by 01-13(P.15). Acceleration / deceleration time is set by the value in 01-14(P.16).
3	<ul style="list-style-type: none"> Inverter starting is triggered by external STF or STR terminals. <p>Note: 1. For detailed operation procedures for the monitoring mode, please refer to section 4.2.3.</p> <p>2. While the motor is running, the user can enter frequency setting mode to change the target frequency for regulating motor speed.</p>
4	<ul style="list-style-type: none"> When terminal STF/STR signals turn off, motor will decelerate until it comes to a full stop. Indicator in RUN will not turn off until the inverter stops outputting.

4.4 Operation

4.4.1 Check and preparation before running

Before running, the following shall be checked:

1. Check if the wiring is correct. Inverter output terminals (U/T1, V/T2, W/T3) cannot be connected to the power. Confirm that grounding terminal (⊕) is well grounded.
2. Confirm that there is no short circuit or short circuit to ground between the terminals or each exposed live part.
3. Confirm all terminal connections, and check if plug connectors (optional) and screws are all fastened.
4. Confirm that the motor is not connected to any load or mechanism.
5. All external switches are in off state before the power is turned on. When the power is turned on, the inverter will not start and no abnormal action will occur.
6. Turn on the power only after the cover is well placed.
7. Do not touch the switch with wet hands.
8. Make sure the following after power on:
No alarm on built-in keypad, check both indicator in **Hz** and **MON** are light up.



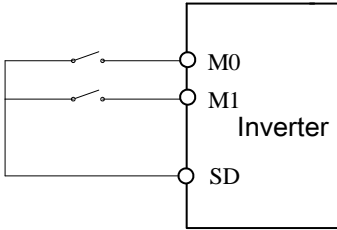
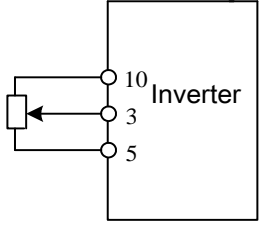

4.4.2 Running methods

For every running method, please refer to basic operation procedures in chapter 4 and parameter description in chapter 5. Select the most appropriate operation methods according to the application requirements and regulations. The most commonly used operation methods are shown below:

Operation method	Source of the target frequency	Source of the operating signal
Built-in keypad operation		<input type="button" value="FWD"/> or <input type="button" value="REV"/>
External terminal signal operation	 <p style="margin-left: 200px;">Parameter setting: 04-01(P.5)=30 04-02(P.6)=10</p>	Input by digital input terminal: STF-SD STR-SD
	 <p style="text-align: center;">terminal 3-5 input</p>	

4.4.3 Test run

- Check cables and abnormalities before the test run. After power on, the inverter is in external mode.
 1. After power on, make sure no alarm on built-in keypad, make sure indicator **Hz** and **MON** is on.
 2. Connect a switch between STF/SD and STR/SD.
 3. Connect a potentiometer between 3-5-10 or provide 0~5V DC between 3 and 5.
 4. Adjust potentiometer or 0~5V DC to a minimum value (under 1V).
 5. If STF is on, forward rotation is activated. If STR is on, reverse rotation is activated. Turn off STF or STR to decelerate the motor until it stops completely.
 6. Check the following:
 - 1). Whether the direction of motor rotation is correct.
 - 2). Whether the rotation is smooth (check for noise and vibration).
 - 3). Whether the acceleration / deceleration is smooth.

- If there is an optional keypad, do the following:
 1. Make sure the keypad is connected to the inverter properly.
 2. Change the operation mode to PU mode after power on, check the target frequency is 50/60Hz.
 3. Use the dial  to set the target frequency at about 5Hz.
 4. Press  for forward rotation and  for reverse rotation. Press  to decelerate the motor until it stops completely.
 5. Check the following:
 - 1) Whether the direction of motor rotation is correct.
 - 2) Whether the rotation is smooth (check for noise and vibration).
 - 3) Whether the acceleration / deceleration is smooth.

- If it runs successfully, continue the test run by increasing the frequency and go through the above procedure. After confirming that there are no abnormalities, it can be put into operation.

Note: If the operation of the inverter and motor is abnormal, stop the operation immediately and check the cause of the abnormality according to "Troubleshooting". After the inverter stops outputting, if the main circuit power terminals R/L1, S/L2, T/L3 are not disconnected, if the inverter's output terminals U/T1, V/T2, W/T3 are touched, it may cause an electric shock. In addition, even if the main circuit power supply is turned off, due to the charging voltage on the filter capacitor, it will take a certain time for the discharge to end. After the main circuit power supply is cut off, wait for 10 minutes and test the intermediate DC circuit voltage with a voltmeter to confirm that it is below the safe voltage value before you can touch the internal circuit of the inverter.

5. PARAMETER DESCRIPTION

5.1 System parameter group 00

Group	Parameter Number	Name	Setting Range	Default	Page
00-00	P.90	Inverter model	Read only	---	49
00-01	P.188	Firmware version	Read only	---	49
00-02	P.996 ~ P.999	Parameter restoration	0: Off	0	50
			1: Clear alarm history (P.996=1)		
			2: Reset inverter (P.997=1)		
			3: Restore all parameters to default (P.998=1)		
			4: Restore some parameters to default 1 (P.999=1)		
			5: Restore some parameters to default 2 (P.999=2)		
00-03	P.77	Selection of parameters write protection	0: Parameters can be written only when the motor stops.	0	52
			1: Parameters cannot be written.		
			2: Parameters can also be written when the motor is running.		
			3: Parameters cannot be read when in password protection.		
00-04	P.294	Password parameter	0~65535	0	52
00-05	P.295	Password setup	2~65535	0	52
00-06	P.110	Built-in keypad monitor selection	X0 :When inverter starts, built-in keypad enters monitor mode automatically, screen displays output frequency (with slip compensation).	2	54
			X1 : When inverter starts, built-in keypad displays target frequency.		
			X2 :When inverter starts, built-in keypad enters monitor mode automatically, screen displays steady state output frequency		
			X3 :When inverter starts, built-in keypad enters monitor mode automatically, screen displays current pressure and feedback pressure of the constant pressure system in percentage		
			X4 : When inverter starts, built-in keypad doesn't enter monitor mode but enter the previous mode before power off		
			X5 :When inverter starts, built-in keypad enters monitor mode automatically, screen displays current pressure and feedback pressure of the constant pressure system		
			4X : When the inverter is standby, the keypad goes into target frequency mode automatically and figure blinks on the keypad panel		

Group	Parameter Number	Name	Setting Range	Default	Page
00-07	P.161	Multi-function display	0: Output AC voltage (V)	0	54
			1: DC bus voltage. (V)		
			2: Inverter temperature rising accumulation rate (%)		
			3: Target pressure of the constant pressure system (%)		
			4: Feedback pressure of the constant pressure system (%)		
			5: Running frequency (Hz)		
			6: Electronic thermal accumulation rate (%)		
			7 : Reserved		
			8: Signal value (mA) of 3-5 input terminals (mA/V).		
			9: Output power (kW).		
			10 : Reserved		
			11: Forward reverse rotation signal. Built-in keypad: Frd is forward , rEv is reverse , STOP is not operating status. External keypad:1 is forward , 2 is reverse, 0 is not operating status.		
			12: NTC temperature (°C)		
			13 : Motor electronic thermal accumulation rate (%)		
			14~18 : Reserved		
19: Digital terminal input state					
20: Digital terminal output state					
21: Actual working carrier frequency					
00-08	P.37	Speed display	0 : Display output frequency(not mechanical speed)	0.0	55
			0.1~5000.0		
			1~50000		
00-09	P.259	Speed display unit selection	0: Speed display unit is 1	1	55
			1: Speed display unit is 0.1		
00-10	P.59	Built-in keypad set target frequency selection	XXX0: Use wheel on built-in keypad or external keypad to set frequency	0	56
			XXX1: Use keypad knob on external keypad to set frequency		
			X0XX:Frequency change done and setting saves in 30 seconds		
			X1XX:Frequency change done and setting saves in 10 seconds		
			X2XX: Every frequency change will not save		
			0XXX: Set frequency will work immediately when use wheel on built-in keypad		
			1XXX: Set frequency will work after pressing SET when use wheel on built-in keypad		
00-11	P.72	Carrier frequency	11K/15KF and below model : 1~15 kHz	5 kHz	57
			15K/18.5KF and above Heavy Duty : 1~15 kHz		
			15K/18.5KF and above Normal Duty : 1~10 kHz		

System parameter group 00

Group	Parameter Number	Name	Setting Range	Default	Page
00-12	P.31	Soft-PWM carrier function selection	0: Off	0	57
			1: When 00-11(P.72)<5,Soft-PWM is on(only apply to V/F control)		
			2 : When 00-11(P.72) > 9, if the IGBT temperature is higher than 60°C, carrier frequency will decrease automatically, when temperature go back to under 40°C, carrier frequency go back to 00-11(P.72) value		
00-13	P.71	Idling brake / DC brake	0: Idling brake	1	58
			1: DC brake		
00-14	P.75	Stop function selection	0: Press STOP button and inverter stop running in PU and H2 mode	1	58
			1: Press STOP button and inverter stop running in all mode.		
00-15	P.78	Prevent forward/reverse rotation selection	0: Forward/reverse rotation are both permitted.	0	59
			1: Prevent reverse rotation (Giving reverse signal decelerates and stops the motor).		
			2: Prevent forward rotation (Giving forward signal decelerates and stops the motor).		
00-16	P.79	Operation mode selection	0: "PU mode", "external mode" and "Jog mode" are interchangeable.	0	59
			1: "PU mode" and "JOG mode" are interchangeable.		
			2: "External mode" only		
			3: "Communication mode" only		
			4: "Combined mode 1"		
			5: "Combined mode 2"		
			6: "Combined mode 3"		
			7: "Combined mode 4"		
8: "Combined mode 5"					
00-17	P.97	Second target frequency selection	0: Frequency set by built-in keypad	0	59
			1: Frequency set by RS485 communication		
			2: Frequency set by analog input		
00-19	P.35	Communication mode selection	0: In communication mode, run signal and frequency is given by communication.	0	59
			1: In communication mode, run signal and frequency is given by external signal.		
00-21	P.300	Motor control mode selection	0 : Induction motor V/F control	0	60
			1 : Reserved		
			2 : Induction motor simple vector control		
00-23	P.186	Motor types selection	0: Normal Duty (ND), on fan and pump duty type.	1	60
			1: Heavy Duty (HD), apply to other duties.		
00-24	P.189	50Hz/60Hz switch selection	0: Frequency related parameter default value is 60Hz.	0	61
			1: Frequency related parameter default value is 50Hz.	1	
00-25	P.990	Parameter display mode setting	0: Parameter is displayed in "group mode"	0	61
			1: Parameter is displayed in "sequence P mode"		

5.1.1 Inverter information

➤ For checking inverter model, control board firmware version, etc.

Parameter	Name	Default	Setting Range	Content
00-00 P.90	Inverter model	Read only	Read only	---
00-01 P.188	Firmware version	Read only	Read only	Inverter control board firmware version

◆ Inverter model

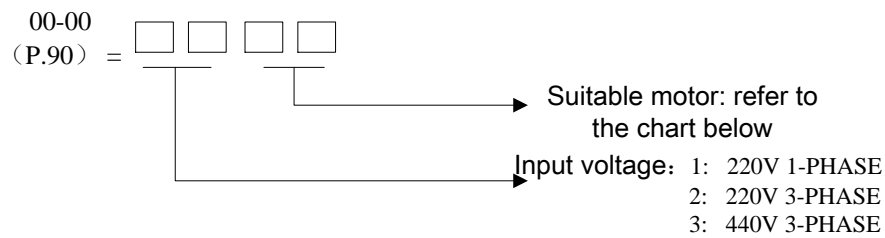

Read Applicable motor capacity:

Value(value of the two low-order bits of 00-00(P.90))	Capacity (kw)
1	0.2K
2	0.4K
3	0.75K
4	1.5K
5	2.2K
6	3.7K
7	5.5K
8	7.5K/11KF
9	11K/15KF
10	15K/18.5KF
11	18.5K/22KF
12	22K

Note: The parameters above are read only, not for write.

5.1.2 Parameter restoration

➤ Set parameters back to default.

Parameter	Name	Default	Setting Range	Content
00-02	Parameter restoration	0	0	Off
			1	Clear alarm history (P.996=1)
			2	Reset inverter (P.997=1)
			3	Restore all parameters to default (P.998=1)
			4	Restore some parameters to default 1 (P.999=1)
			5	Restore some parameters to default 2 (P.999=2)
			6	Restore some parameters to default 3 (P.999=3)

Setting Parameter restoration

- ◆ 1: When 00-02(P.996~P.999) is set to 1, screen will flash **ErLL**, the alarm record will be erased after writing, and 00-02(P.996~P.999) is reset to 0.
- ◆ 2: When 00-02(P.996~P.999) is set to 1, screen will flash **rEST**, and inverter will be reset, then 00-02(P.996~P.999) is reset to 0. After resetting the inverter, the accumulated values in “electronic thermal relay” and “IGBT module thermal relay” will be set to zero.
- ◆ 3: When 00-02(P.996~P.999) is set to 3, screen will flash **ALLC**, all the parameters will be restored to the default values except the parameters in table 1 below. After parameters are restored, 00-02(P.996~P.999) is reset to 0.

Exception The parameters in table 1 below will not be restored to the default values:

Group	No.	Name
00-00	P.90	Inverter model
00-01	P.188	Firmware version
00-23	P.186	Motor types selection
00-24	P.189	50Hz/60Hz switch selection
00-25	P.990	Parameter display mode setting
01-08	P.21	Acceleration/deceleration time increments
06-27	P.292	Total inverter operation time (minutes)
06-28	P.293	Total inverter operation time (days)
06-29	P.296	Total inverter power on time (minutes)
06-30	P.297	Total inverter power on time (days)

- ◆ 4 : When 00-02(P.996~P.999) is set to 4, screen will flash **PrLL**, all the parameters will be restored to the default values except the parameters in table 1 and table 2 below after writing. After parameters are restored, 00-02(P.996~P.999) is reset to 0.

Exception The parameters in table 2 below and table 1 will not be restored to default values:

Group	No.	Name
00-21	P.300	Motor control mode selection
02-25	P.198	Terminal 3-5 minimum input current/ voltage
02-26	P.199	Terminal 3-5 maximum input current/ voltage
02-27	P.196	Percentage corresponds to terminal 3-5 minimum input current/ voltage
02-28	P.197	Percentage corresponds to terminal 3-5 maximum input current/ voltage
02-61	P.141	Polarity of percentage corresponds to terminal 3-5 current/ voltage signal
05-00	P.301	Motor specifications automatic measurement
05-01	P.302	Motor rated power
05-02	P.303	Motor poles
05-03	P.304	Motor rated voltage
05-04	P.305	Motor rated frequency
05-05	P.306	Motor rated current
05-06	P.307	Motor rated rotation speed
05-07	P.308	IM Motor excitation current
05-08	P.309	IM motor stator resistance
11-00	P.320	Slip compensation gain
11-01	P.321	Torque boost filter coefficient

- ◆ 5: User registered parameter 15-00~15-19(P.900~P.919) and the parameters set in 15-00~15-19(P.900~P.919) and the parameters in table 1 above will not be restored to default values. After parameters are restored, 00-02(P.996~P.999) is reset to 0.
- ◆ 6: User registered parameter 15-00~15-19(P.900~P.919) and the parameters set in 15-00~15-19(P.900~P.919) and the parameters in table 1 and table 2 above will not be restored to default values. After parameters are restored, 00-02(P.996~P.999) is reset to 0.

Note: When the parameter is restored to default value or some of the parameters are restored to default value, be sure to wait for the screen to display *End*, which means that it's complete, and then perform other operations.

5.1.3 Parameter protection

➤ It is used to select whether parameters can be written to prevent changing parameter values due to misoperation.

Parameter	Name	Default	Setting Range	Content
00-03 P.77	Selection of parameters write protection	0	0	Parameters can be written only when the motor stops.
			1	Parameters cannot be written.
			2	Parameters can also be written when the motor is running.
			3	Parameters cannot be read when in password protection.
00-04 P.294	Password parameter	0	0~65535	Write the registered password to decrypt parameter protection.
00-05 P.295	Password setup	0	2~65535	Register password for parameter protection setting.

Setting Selection of parameters write protection

◆ Write parameters only during stop (00-03(P.77)="0"initial value)

Exception When running, the parameters below can still be written:

Group	No.	Name
00-03	P.77	Selection of parameters write protection
00-07	P.161	Multi-function display
02-25	P.198	Terminal 3-5 minimum input current/ voltage
02-26	P.199	Terminal 3-5 maximum input current/ voltage
02-27	P.196	Percentage corresponds to terminal 3-5 minimum input current/ voltage
02-28	P.197	Percentage corresponds to terminal 3-5 maximum input current/ voltage
02-52	P.56	Inverter rated current display level
04-00	P.4	Speed 1 (high speed)
04-01	P.5	Speed 2 (medium speed)
04-02	P.6	Speed 3 (low speed)
04-03	P.24	Speed 4
04-04	P.25	Speed 5
04-21	P.133	Programmed operation mode speed 3
04-22	P.134	Programmed operation mode speed 4
04-23	P.135	Programmed operation mode speed 5
04-24	P.136	Programmed operation mode speed 6
04-25	P.137	Programmed operation mode speed 7
04-26	P.138	Programmed operation mode speed 8
06-17	P.261	Maintenance alarm function

Group	No.	Name
04-05	P.26	Speed 6
04-06	P.27	Speed 7
04-07	P.142	Speed 8
04-08	P.143	Speed 9
04-09	P.144	Speed 10
04-10	P.145	Speed 11
04-11	P.146	Speed 12
04-12	P.147	Speed 13
04-13	P.148	Speed 14
04-14	P.149	Speed 15
04-19	P.131	Programmed operation mode speed 1
04-20	P.132	Programmed operation mode speed 2
06-40	P.288	Alarm record code query
06-42	P.290	Alarm record message query
08-03	P.225	PID target value
08-18	P.223	Analog feedback signal bias
08-19	P.224	Analog feedback signal gain
10-19	P.230	Dwell frequency at acceleration
10-21	P.232	Dwell frequency at deceleration
10-46	P.268	Voltage stall level

- ◆ Most parameters cannot be written. (00-03(P.77)="1")

Exception Parameters below can be written:

Group	No.	Name
00-03	P.77	Selection of parameters write protection
00-16	P.79	Operation mode selection

- ◆ When running, most parameters can be written. (00-03(P.77)="2")

Exception When running, the parameters below cannot be written:

Group	No.	Name
00-00	P.90	Inverter model
00-01	P.188	Firmware version
00-11	P.72	Carrier frequency
00-15	P.78	Prevent forward/reverse rotation selection
00-16	P.79	Operation mode selection
00-19	P.35	Communication mode selection
06-01	P.22	Stall prevention operation level

Group	No.	Name
06-08	P.155	Over torque detection level
06-27	P.292	Total inverter operation time (minutes)
06-28	P.293	Total inverter operation time (days)
06-41	P.289	Alarm record code display
06-43	P.291	Alarm record message display
06-29	P.296	Total inverter power on time (minutes)
06-30	P.297	Total inverter power on time (days)

- ◆ When in password protection, parameters cannot be read. (00-03(P.77)="3")

Exception Parameters below can still be read:

Group	No.	Name
00-00	P.90	Inverter model
00-01	P.188	Firmware version
00-04	P.294	Password parameter
00-05	P.295	Password setup
00-08	P.37	Speed display
00-10	P.59	Built-in keypad set target frequency selection
00-16	P.79	Operation mode selection
00-25	P.990	Parameter display mode setting
01-00	P.1	Maximum frequency
01-01	P.2	Minimum frequency
02-21	P.39	Terminal 3-5/ keypad knob maximum operation frequency
06-41	P.289	Alarm record code display
06-43	P.291	Alarm record message display

Setting

Password protection

- ◆ Register a password
 1. Write a number (2 ~ 65535) in 00-05(P.295) as a password, password protection takes effect immediately;
 2. After registering a password, 00-05(P.295)=1;
- ◆ Unlock password protection
 1. Write the correct password in 00-04(P.294), and then password protection will be unlocked;
 2. After unlocking the password, 00-04(P.294)=0, 00-05(P.295)=1;
 3. If turn the power off and then turn on, inverter will still restore to the password protection status.

System parameter group 00

◆ Password all clear

1. Write the correct password in 00-04(P.294) to unlock the password protection;
2. Write 0 in 00-05(P.295), password will be all cleared.

Note: If password is forgotten, enter the same incorrect password three times in 00-04(P.294), and the interval between two consecutive times is not more than 10s. The password can be cleared and the user parameters will be automatically restored to default.

5.1.4 Monitoring function

➤ Item to monitor on built-in keypad can be selected.

Parameter	Name	Default	Setting Range	Content
00-06 P.110	Built-in keypad monitor selection	2	X0	When inverter starts, built-in keypad enters monitor mode automatically, screen displays output frequency (Note 1).
			X1	When inverter starts, built-in keypad displays target frequency.
			X2	When inverter starts, built-in keypad enters monitor mode automatically, screen displays steady state output frequency
			X3	When inverter starts, built-in keypad enters monitor mode automatically, screen displays current pressure and feedback pressure of the constant pressure system in percentage(Note 2)
			X4	When inverter starts, built-in keypad doesn't enter monitor mode but enter the previous mode before power off
			X5	When inverter starts, built-in keypad enters monitor mode automatically, screen displays current pressure and feedback pressure of the constant pressure system
			4X	When the inverter is standby, the keypad goes into target frequency mode automatically and figure blinks on the keypad panel
00-07 P.161	Multi-function display	0	0	Output AC voltage (V)
			1	DC bus voltage. (V)
			2	Inverter temperature rising accumulation rate (%)
			3	Target pressure of the constant pressure system (%)
			4	Feedback pressure of the constant pressure system (%)
			5	Running frequency (Hz)
			6	Electronic thermal accumulation rate (%)
			8	Signal value (mA) of 3-5 input terminals (mA/V).
			9	Output power (kW).
			11	Forward reverse rotation signal. Built-in keypad: Frd is forward , rEv is reverse , STOP is not operating status. External keypad:1 is forward , 2 is reverse, 0 is not operating status.
			12	NTC temperature (°C)
			13	Motor electronic thermal accumulation rate (%)
			14~18	Reserved
			19	Digital terminal input state (Note 3)
20	Digital terminal output state (Note 4)			
21	Actual working carrier frequency			

Note: 1. The “output frequency” here is the value after slip compensation.

2. The multi-function display function is implemented in the monitor voltage mode. For switching to monitor voltage mode, refer to section 4.2.3.

3. Digital terminal input state detail



b3	b2	b1	b0
M1	M0	STR	STF

4. Digital terminal output state detail

b1	b0
A-C	0

Display

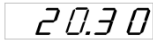
Keypad monitoring selection

- ◆ Display current pressure and feedback pressure of the constant pressure system in percentage (00-06(P.110)=3)
The screen shows two sections. A decimal point is used to separate the boundaries, on the left is the target pressure and on the right is the feedback pressure of the constant pressure system in percentage.
As shown in this figure :  , “20” means the target pressure of the constant pressure system is 20%, the target value will be 20%*08-43(P.251) ; “30” means the feedback pressure of the constant pressure system is 30%, the feedback value will be 30%*08-43(P.251).
- ◆ Displays current pressure and feedback pressure of the constant pressure system (00-06(P.110)=5)
The screen shows two sections. A space is used to separate the boundaries, on the left is the target pressure and on the right is the feedback pressure of the constant pressure system
As shown in this figure:  ; “2.0” means the target pressure of the constant pressure system is 2.0 , “3.0” means the feedback pressure of the constant pressure system is 3.0.

Display

Multi-function display

- ◆ The display value will show in the monitor voltage mode. Please refer to 4.2.3 for flow chart of monitoring mode.

5.1.5 Speed display

- In “monitoring output frequency” mode, the screen displays corresponding machine speed.

Parameter	Name	Default	Setting Range	Content
00-08 P.37	Speed display	0.0	0	Display output frequency(not mechanical speed)
			0.1~5000.0	When 00-09(P.259)=1
			1~50000	When 00-09(P.259)=0
00-09 P.259	Speed display unit selection	1	0	Speed display unit is 1
			1	Speed display unit is 0.1

Setting

Speed display

- ◆ The setting value of 00-08(P.37) is the speed of motor when output frequency is 60Hz.
For example:
 1. If the transmitting belt speed is 950 m/minute when the inverter output frequency is 60Hz, set 00-08(P.37) = 950.
 2. After setting, in the keypad “output frequency monitor mode” , the screen will display the speed of the transmitting belt.

Note: The machine speed on the screen is the theoretical value calculated proportionately by the inverter output frequency and the setting value of 00-08(P.37). So there’s minute discrepancy between the displayed machine speed and the actual one.

5.1.6 Built-in keypad set target frequency selection

➤ Select different frequency setting mode of the built-in keypad.

Parameter	Name	Default	Setting Range	Content
00-10 P.59	Built-in keypad set target frequency selection	0	XXX0	Use wheel on built-in keypad or external keypad to set frequency
			XXX1	Use keypad knob on external keypad to set frequency
			X0XX	Frequency change done and setting saves in 30 seconds
			X1XX	Frequency change done and setting saves in 10 seconds
			X2XX	Every frequency change will not save
			0XXX	Set frequency will work immediately when use wheel on built-in keypad
			1XXX	Set frequency will work after pressing SET when use wheel on built-in keypad

Setting Built-in keypad set target frequency selection

◆ 00-10 (P.59) is set by unit, 4 in total.

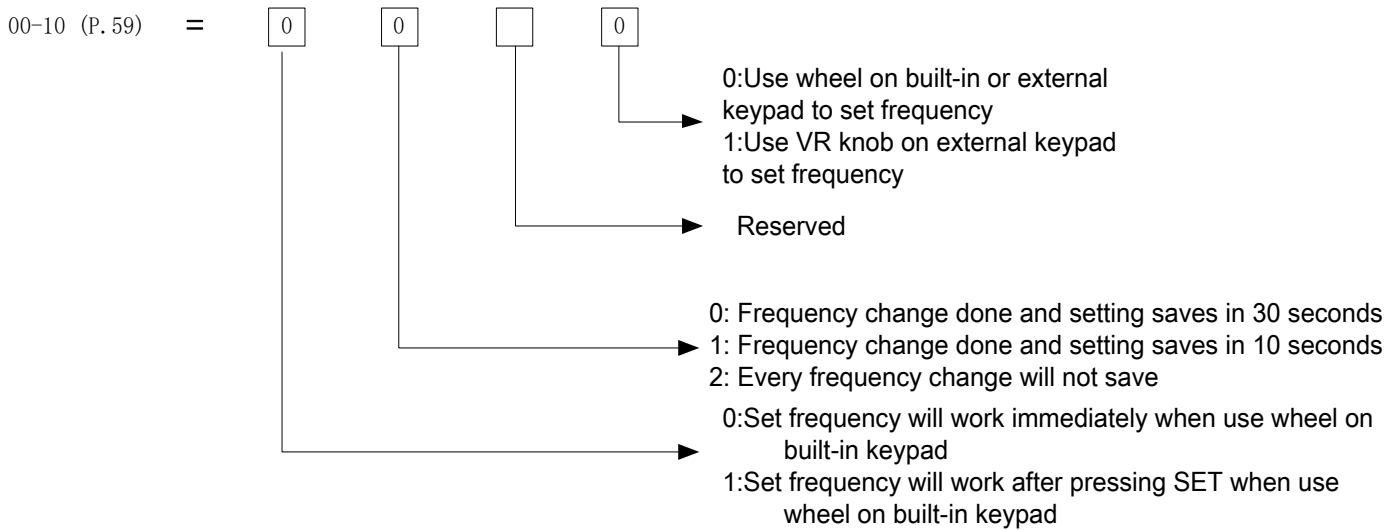

Note: 1. The set value on the hundreds digit of 00-10 (P.59) is only for the frequency set by dial on keypad.
 2. When 00-10 (P.59) ones digit is 1, if the external keypad has a VR knob, the VR knob setting frequency is valid. If the external keypad does not have a VR knob, then up down keys of the external keypad is valid.

5.1.7 PWM carrier frequency

➤ The motor sound can be changed by adjusting PWM carrier frequency properly.

Parameter	Name	Default	Setting Range	Content
00-11 P.72	Carrier frequency	5kHz	1~15kHz	11K/15KF and below mode
			1~15kHz	15K/18.5KF and above Heavy Duty
			1~10kHz	15K/18.5KF and above Normal Duty
00-12 P.31	Soft-PWM carrier function selection	0	0	Off
			1	When 00-11(P.72)<5, Soft-PWM is on(only apply to V/F control)
			2	When 00-11(P.72) > 9, if the IGBT temperature is higher than 60°C, carrier frequency will decrease automatically, when temperature go back to under 40°C, carrier frequency go back to 00-11(P.72) value.

Setting

Carrier frequency

- ◆ The higher the carrier frequency, the lower the motor acoustic noise, but will result in greater leakage current and larger noise generated by the inverter.
- ◆ The higher the carrier frequency, the more energy inverter will consume, and temperature will also be higher.
- ◆ If mechanical resonance occurred in a system, 00-11(P.72) can also be adjusted to lower the vibration.
- ◆ The higher the carrier frequency, the lower the rated current of the inverter. This is to prevent the inverter from overheating and prolong the service life of the IGBT, so such protective measures are necessary. The relationship curve between rated current and carrier frequency is shown in the figure below:

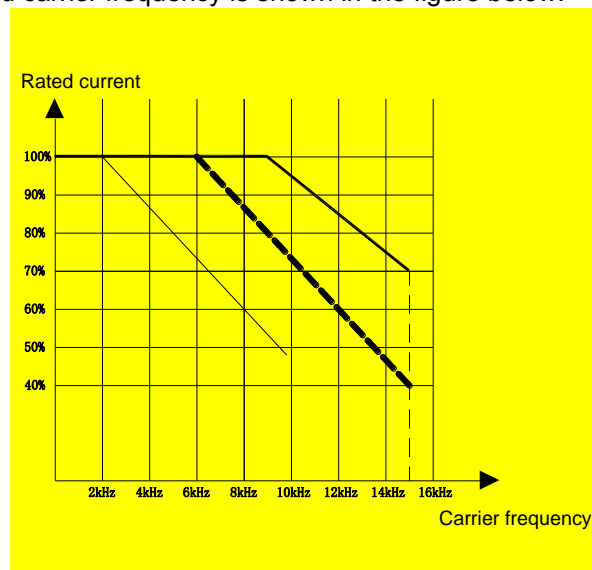

The corresponding frame is as follows:

A/B frame

C/D frame Normal Duty

C/D frame Heavy Duty

Note: The setting value of carrier frequency is best to be 8 times larger than the target frequency.



Setting

Carrier operation selection V/F

- ◆ Soft-PWM control is a control method that changes the motor noise from a metallic sound into an inoffensive, complex tone.
- ◆ Motor noise modulation control is when the inverter changes its carrier frequency from time to time during operation, metal noises generated by the motor will not be in a single frequency, so sharp single frequency noises will be reduced.
- ◆ This action is only valid under V/F control, that is, it is valid when 00-21 (P.300)=0.

5.1.8 Stop operation selection

➤ Select the inverter stop method

Parameter	Name	Default	Setting Range	Content
00-13 P.71	Idling brake / DC brake	1	0	Idling brake
			1	DC brake
00-14 P.75	STOP RESET function selection	1	0	Press  button and inverter stop running in PU and H2(combine mode 2) mode
			1	Press  button and inverter stop running in all mode.

Setting Idling brake / DC brake

◆ Idling brake (00-13(P.71)=0)

After receiving stop signal, inverter stops output immediately, and the motor idle freely.

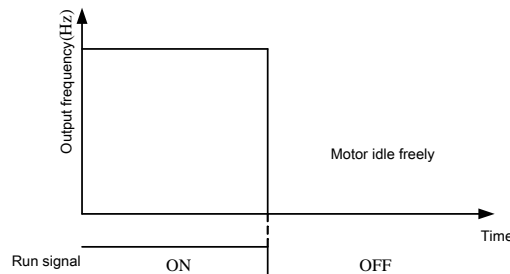

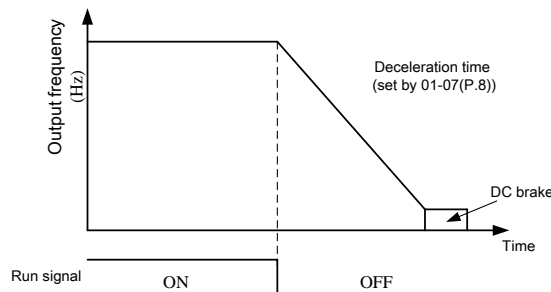

◆ DC braking(00-13(P.71)=1)

After receiving stop signal, inverter decelerates according to the acceleration/deceleration curve until it stops.



Setting button function selection

◆ Press  button to stop during operation (00-14(P.75)=1)

Note: When running in non-PU and H2 modes, pressing the  button will display E0 and inverter will stop and cannot run. Please follow the steps below to cancel this state:

1. If the start signal is given from digital input terminal, switch off the signal (Note 1);
2. Press  button for over 1.0 second to remove E0 state.

◆ No matter in what setting, after an alarm occurs, press the  key for more than 1.0 second to reset the inverter.

Note : 1. In programmed operation mode, it is not necessary to switch off the start signal. Inverter will run at the section where it stopped after reset.
2. After the inverter is reset, accumulated heat values in "electronic thermal relay" and "IGBT module thermal relay" will clear to zero.

5.1.9 Forward/reverse rotate prevent function

- Set this parameter to limit the motor rotation to only one direction, and prevent reverse rotation fault resulting from the incorrect input of the start signal.

Parameter	Name	Default	Setting Range	Content
00-15 P.78	Prevent forward/ reverse rotation selection	0	0	Forward/reverse rotation are both permitted.
			1	Prevent reverse rotation (Giving reverse signal decelerates and stops the motor).
			2	Prevent forward rotation (Giving forward signal decelerates and stops the motor).

Note: It is valid to all start signals.

5.1.10 Operation mode selection

- Select the operation mode of the inverter, and determine the source of start signal and target frequency.

Parameter	Name	Default	Setting Range	Content
00-16 P.79	Operation mode selection	0	0	"PU mode", "external mode" and "Jog mode" are interchangeable.
			1	"PU mode" and "JOG mode" are interchangeable.
			2	"External mode" only
			3	"Communication mode" only
			4	"Combined mode 1"
			5	"Combined mode 2"
			6	"Combined mode 3"
			7	"Combined mode 4"
			8	"Combined mode 5"
00-17 P.97	Second target frequency selection	0	0	Frequency set by built-in keypad
			1	Frequency set by RS485 communication
			2	Frequency set by analog input
00-19 P.35	Communication mode selection	0	0	In communication mode, run signal and frequency is given by communication.
			1	In communication mode, run signal and frequency is given by external signal.

 Setting Operation mode selection

- ◆ Please refer to Section 4.3 for detailed setting and usage.

 Setting Communication mode instruction selection

- ◆ When 00-16(P.79)=3, select communication mode:
If 00-19(P.35)=0, start and frequency command is given by communication;
If 00-19(P.35)=1, start and frequency command is given by external terminals.

5.1.11 Motor control mode selection

➤ Choose control mode for the AC motor

Parameter	Name	Default	Setting Range	Content
00-21 P.300	Motor control mode selection	0	0	Induction motor V/F control
			2	Induction motor simple vector control

Setting Motor control mode

- ◆ Induction motor V/F control: user can design proportion of V/F as required and can control multiple motors simultaneously.
- ◆ Induction motor simple vector control: Output voltage is increased to compensate the frequency change when motor load is increased.

Note : 1. The motor capacity must be the same level or one level lower than the inverter capacity.
 2. When the automatic measurement function is used, if motor can rotate, please set 05-00(P.301)=1 (dynamic measurement). The load must be completely separated from motor. During Auto-tuning if the motor cannot rotate due to environment, please set 05-00 (P.301) = 2 (static measurement).
 3. General flux vector control: The control performance can be enhanced by Auto-tuning.

5.1.12 Motor types selection

➤ Modify the applicable load type of the inverter.

Parameter	Name	Default	Setting Range	Content
00-23 P.186	Motor types selection	1	0	Normal Duty (ND), on fan and pump duty type.
			1	Heavy Duty (HD), apply to other duties.

Setting Motor types selection

- ◆ In order to switch to heavy duty setting (00-23(P.186)="0") , be sure to perform the following steps. After these steps are completed, the duty type will be successfully switched.
 1. Set 00-23(P.186)=0 ;
 2. Set 00-02=3 (P.998=1) to set all parameters to default;
 3. Set 00-02=2 (P.997=1) to reset inverter.

Note: 1.00-23(P.186) is only effective to frame C/D

5.1.13 50/60Hz switch selection

- Select between 50Hz or 60Hz according to different power source frequency or default motor frequency, this effects all frequency-related parameters.

Parameter	Name	Default	Setting Range	Content
00-24	50Hz/60Hz	0	0	Frequency related parameter default value is 60Hz.
P.189	switch selection	1	1	Frequency related parameter default value is 50Hz.

Setting 50/60Hz switch selection

- ◆ The following two steps shows how to set frequency related parameter to 60Hz system:
 1. Set 00-24(P.189)=0;
 2. Set 00-02=3(P.998=1) to set all parameters to default, at this point frequency-related parameters of the inverter will be reset to 60Hz.
- ◆ The following parameters are affected:

Group	No.	Name
01-03	P.3	Base frequency
01-09	P.20	Acceleration/deceleration reference frequency
02-21	P.39	Terminal 3-5input signal maximum operation frequency
05-03	P.304	Motor rated voltage

Group	No.	Name
05-04	P.305	Motor rated frequency
05-06	P.307	Motor rated rotation speed
06-03	P.66	Stall prevention operation reduction starting frequency
08-14	P.182	Upper integral limit

5.1.14 Parameter mode setting

- Select “Sequence P mode” or “group mode” to display parameters.

Parameter	Name	Default	Setting Range	Content
00-25 P.990	Parameter display mode setting	0	0	Parameter is displayed in “group mode”
			1	Parameter is displayed in “sequence P mode”

Display Parameter mode setting

- ◆ “Group mode” displaying

00-25

- ◆ “Sequence P mode” displaying

P. 0

Note: After setting 1.00-25(P.990), please reset the inverter or restarter the inverter,It will be effective after the parameter displays mode selection

5.2 Basic Parameter Group 01

Group	Parameter Number	Name	Setting Range	Default	Page
01-00	P.1	Maximum frequency	0.00 ~ 01-02 (P.18) Hz	120.00Hz	64
01-01	P.2	Minimum frequency	0 ~ 120.00Hz	0.00Hz	64
01-02	P.18	High-speed maximum frequency	01-00 (P.1) ~ 650.00Hz	120.00Hz	64
01-03	P.3	Base frequency	50Hz system setting: 0 ~ 650.00Hz	50.00Hz	65
			60Hz system setting: 0 ~ 650.00Hz	60.00Hz	
01-04	P.19	Base voltage	0 ~ 1000.0V	99999	65
			99999 : Change according to the input voltage		
01-05	P.29	Acceleration/deceleration curve selection	0: Linear acceleration /deceleration curve	0	66
			1: S shape acceleration /deceleration curve 1		
			2: S shape acceleration /deceleration curve 2		
			3: S shape acceleration /deceleration curve 3		
01-06	P.7	Acceleration time	3.7K and below model : 0 ~ 360.00s/0 ~ 3600.0s	5.00s	66
			5.5K model : 0 ~ 360.00s/0 ~ 3600.0s	10.00s	
			7.5K/11KF and above model : 0 ~ 360.00s/0 ~ 3600.0s	20.00s	
01-07	P.8	Deceleration time	3.7K and below model : 0 ~ 360.00s/0 ~ 3600.0s	5.00s	66
			5.5K~7.5K/11KF model : 0 ~ 360.00s/0 ~ 3600.0s	10.00s	
			11K/15KF and above model : 0 ~ 360.00s/0 ~ 3600.0s	30.00s	
01-08	P.21	Acceleration/deceleration time increments	0: Time increment is 0.01s	0	66
			1: Time increment is 0.1s		
01-09	P.20	Acceleration/deceleration reference frequency	50Hz system setting: 1.00 ~ 650.00Hz	50.00Hz	66
			60Hz system setting: 1.00 ~ 650.00Hz	60.00Hz	
01-10	P.0	Torque boost	0.75K and under :0 ~ 30.0%	6.0%	68
			1.5K~3.7K model : 0 ~ 30.0%	4.0%	
			5.5K~7.5K/11KF model : 0 ~ 30.0%	3.0%	
			11K/15KF and above model : 0 ~ 30.0%	2.0%	
01-11	P.13	Starting frequency	0 ~ 60.00Hz	0.50Hz	68
01-12	P.14	Load pattern selection	0: For constant torque loads (conveyor belt, etc.)	0	69
			1: For variable torque loads (fans and pumps, etc.)		
			2 ~ 3 : For Lifting loads		
			4: Multipoint V/F curve		
			5~13: Special two-point V/F curve		
01-13	P.15	JOG frequency	0 ~ 650.00Hz	5.00Hz	71
01-14	P.16	JOG Acc/ Dec time	0 ~ 360.00s/0 ~ 3600.0s	0.50s	71
01-15	P.28	Output frequency filter time	0 ~ 31	0	72
01-16	P.91	Frequency jump 1A	0 ~ 650.00Hz	99999	72
			99999 : Off		
01-17	P.92	Frequency jump 1B	0 ~ 650.00Hz	99999	72
			99999 : Off		

Group	Parameter Number	Name	Setting Range	Default	Page
01-18	P.93	Frequency jump 2A	0 ~ 650.00Hz	99999	72
			99999 : Off		
01-19	P.94	Frequency jump 2B	0 ~ 650.00Hz	99999	72
			99999 : Off		
01-20	P.95	Frequency jump 3A	0 ~ 650.00Hz	99999	72
			99999 : Off		
01-21	P.96	Frequency jump 3B	0 ~ 650.00Hz	99999	72
			99999 : Off		
01-22	P.44	Second acceleration time	0 ~ 360.00s/0 ~ 3600.0s	99999	74
			99999 : Off		
01-23	P.45	Second deceleration time	0 ~ 360.00s/0 ~ 3600.0s	99999	74
			99999 : Off		
01-24	P.46	Second torque boost	0 ~ 30.0%	99999	74
			99999 : Off		
01-25	P.47	Second base frequency	0 ~ 650.00Hz	99999	74
			99999 : Off		
01-26	P.98	Middle frequency 1	0 ~ 650.00Hz	3.00Hz	75
01-27	P.99	Output voltage 1 of middle frequency	0 ~ 100.0%	10.0%	75
01-28	P.162	Middle frequency 2	0 ~ 650.00Hz	99999	75
			99999 : Off		
01-29	P.163	Output voltage 2 of middle frequency	0 ~ 100.0%	0.0%	75
01-30	P.164	Middle frequency 3	0 ~ 650.00Hz	99999	75
			99999 : Off		
01-31	P.165	Output voltage 3 of middle frequency	0 ~ 100.0%	0.0%	75
01-32	P.166	Middle frequency 4	0 ~ 650.00Hz	99999	75
			99999 : Off		
01-33	P.167	Output voltage 4 of middle frequency	0 ~ 100.0%	0.0%	75
01-34	P.168	Middle frequency 5	0 ~ 650.00Hz	99999	75
			99999 : Off		
01-35	P.169	Output voltage 5 of middle frequency	0 ~ 100.0%	0.0%	75
01-36	P.255	S curve time at the beginning of acceleration	0 ~ 25.00s/0 ~ 250.0s	0.20s	76
01-37	P.256	S curve time at the end of acceleration	0 ~ 25.00s/0 ~ 250.0s	99999	76
			99999 : Off		
01-38	P.257	S curve time at the beginning of deceleration	0 ~ 25.00s/0 ~ 250.0s	99999	76
			99999 : Off		
01-39	P.258	S curve time at the end of deceleration	0 ~ 25.00s/0 ~ 250.0s	99999	76
			99999 : Off		
01-40	P.219	Remote function acc/dec time selection	0 : Use default acc/dec time (same as regular mode)	0	77
			1 : Use second acc/dec time		

5.2.1 Limiting the output frequency

➤ Output frequency can be limited. Fix the output frequency at the upper and lower limits.

Parameter	Name	Default	Setting Range	Content
01-00 P.1	Maximum frequency	120.00Hz	0.00 ~ 01-02 (P.18) Hz	--
01-01 P.2	Minimum frequency	0.00Hz	0 ~ 120.00Hz	Output minimum frequency
01-02 P.18	High-speed maximum frequency	120.00Hz	01-00 (P.1) ~ 650.00Hz	Set when need inverter to run over 120Hz

Setting Maximum frequency, high-speed maximum frequency

- ◆ The “maximum frequency” and the “high-speed maximum frequency” are interrelated:
 1. If the target frequency upper limit is set below 01-00(P.1), use 01-00(P.1) as the maximum frequency;
 2. If the target frequency upper limit is above 01-00(P.1), use 01-02(P.18) as the maximum frequency.
- ◆ If $01-00(P.1) < 01-01(P.2)$, the steady output frequency will be fix at 01-00(P.1) value.
- ◆ When setting the target frequency in PU mode, the frequency set value cannot exceed the value of 01-00(P.1).

Setting Minimum frequency

- ◆ If the target frequency $\leq 01-01(P.2)$, the steady output frequency equals to = 01-01(P.2).
- ◆ If $01-01(P.2) < \text{target frequency} \leq 01-00(P.1)(01-02(P.18))$, the steady output frequency equals to target frequency.

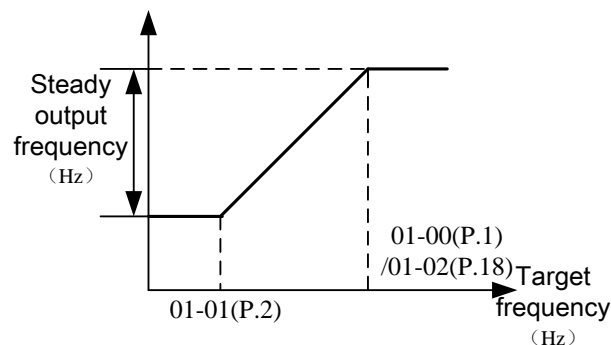

5.2.2 Base frequency, base voltage

- Use this function to adjust the inverter outputs (voltage, frequency) to match with the motor rating.

Parameter	Name	Default	Setting Range	Content
01-03 P.3	Base frequency	50.00Hz	0.00 ~ 650.00Hz	50Hz system (00-24(P.189)=1)
		60.00Hz		60Hz system (00-24(P.189)=0)
01-04 P.19	Base voltage	99999	0 ~ 1000.0V	Set base voltage according to motor rating.
			99999	Base voltage is equal to power source voltage.

Setting Base frequency

- ◆ Generally, 01-03(P.3) is set as the rated frequency of motor.
When the rated frequency on the motor nameplate is "50 Hz", make sure to set base frequency to "50 Hz". If set it to "60 Hz" the voltage will drop too much, causing torque to drop. As a result, the inverter may trip due to overload.
- ◆ When running the motor requires switching to the commercial power supply, set the commercial power supply voltage value in 01-03(P.3).

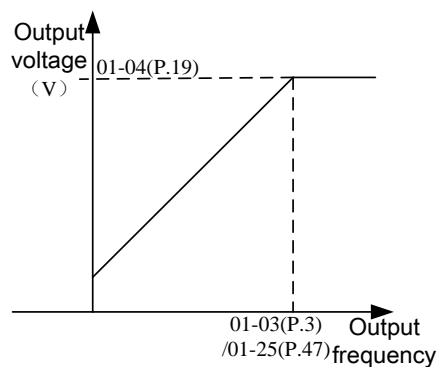

Note: For second base frequency please refer to 5.2.10 the second function.

Setting Base voltage

- ◆ When the output frequency is lower than the base frequency, the output voltage of the inverter will increase as the output frequency increases; when the output frequency reaches the base frequency 01-03(P.3), the output voltage will reach the base voltage. If the output frequency exceeds the base frequency and still rising, the output voltage will be fixed at the base voltage.

5.2.3 Acceleration/deceleration time setting

➤ Use this function to set motor acceleration/deceleration time.

Parameter	Name	Default	Setting Range	Content
01-05 P.29	Acceleration/ deceleration curve selection	0	0	Linear acceleration /deceleration curve
			1	S shape acceleration /deceleration curve 1 (Note 1)
			2	S shape acceleration /deceleration curve 2 (Note 2)
			3	S shape acceleration /deceleration curve 3 (Note 3)
01-06 P.7	Acceleration time	5.00s	0 ~ 360.00s/ 0 ~ 3600.0s	2.2K and below
		10.00s		5.5K model
		20.00s		7.5K/11KF and above model
01-07 P.8	Deceleration time	5.00s	0 ~ 360.00s/ 0 ~ 3600.0s	3.7K and below
		10.00s		5.5K~7.5K/11KF model
		30.00s		11K/15KF and above model
01-08 P.21	Acceleration/ deceleration time increments	0	0	Time increment is 0.01s
			1	Time increment is 0.1s
01-09 P.20	Acceleration/ deceleration reference frequency	50.00Hz	1.00 ~ 650.00Hz	50Hz system setting (00-24(P.189)=1)
		60.00Hz		60Hz system setting(00-24(P.189)=0)

Setting Acceleration/deceleration curve selection

◆ Linear acceleration /deceleration curve (01-05(P.29)=0)

An acceleration slope is formed by the combination of 01-06(P.7) and 01-09(P.20). A deceleration slope is formed by the combination of 01-07(P.8) and 01-09(P.20).

When the target frequency varies, it increases according to the “acceleration slope” or decreases according to the “deceleration slope” linearly. See the figure below:

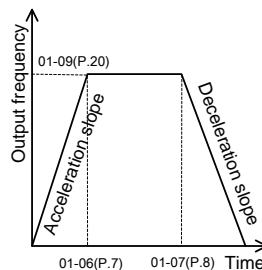

◆ S shape acceleration /deceleration curve 1 (01-05(P.29)=1)

An acceleration slope is formed by the combination of 01-06(P.7) and 01-03(P.3). A deceleration slope is formed by the combination of 01-07(P.8) and 01-03(P.3).

The acceleration / deceleration curve has an S-shape change according to the “acceleration / deceleration slope”.

The S-shape equation between 0 and 01-03 (P.3) is:

$$f = [1 - \cos(\frac{90^\circ \times t}{01-06(P.7)})] \times 01-03(P.3)$$

The S-shape equation above 01-03 (P.3) is:

$$t = \frac{4}{9} \times \frac{01-06(P.7)}{01-03(P.3)^2} \times f^2 + \frac{5}{9} \times 01-06(P.7)$$

t = time; f = output frequency

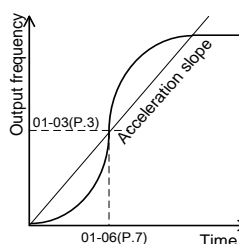

◆ S shape acceleration /deceleration curve 2(01-05(P.29)=2)

An acceleration slope is formed by the combination of 01-06(P.7) and 01-09(P.20). A deceleration slope is formed by the combination of 01-07(P.8) and 01-09(P.20).

When the target frequency varies, the acceleration increases S-shape according to the “acceleration slope”. The deceleration decreases S-shape according to the “deceleration slope”. As shown in the figure below, when frequency is adjusted from f_0 to f_2 , it accelerates S-shape once, and the time is $01-06(P.7) \times (f_2-f_0) / 01-09(P.20)$. Then if the frequency is adjusted from f_2 to f_3 , it accelerates S-shape the second time, and the time is $01-06(P.7) \times (f_3-f_2) / 01-09(P.20)$.

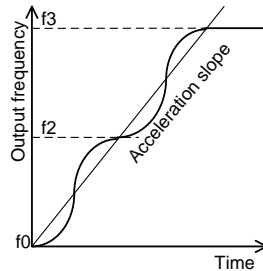

◆ S shape acceleration /deceleration curve 3(01-05(P.29)=3)

Please refer to 5.2.12 S pattern time setting.

Setting Acceleration/deceleration time increments

- ◆ When 01-08(P.21)=0, minimum acceleration / deceleration time (01-06(P.7), 01-07(P.8), 01-14(P.16), 01-22(P.44), 01-23(P.45), 01-36~01-39(P.255~P.258), 04-35(P.111)~04-42(P.118), 10-27~10-28(P.238~P.239) increment is 0.01s.
- ◆ When 01-08(P.21)=1, minimum acceleration / deceleration time (01-06(P.7), 01-07(P.8), 01-14(P.16), 01-22(P.44), 01-23(P.45), 01-36~01-39(P.255~P.258), 04-35(P.111)~04-42(P.118), 10-27~10-28(P.238~P.239) increment is 0.1s.

Setting Acceleration / deceleration reference frequency

- ◆ When the output frequency of the inverter is accelerated from 0Hz to 01-09(P.20), the required time is defined as “acceleration time”.
- ◆ When the output frequency of the inverter is decelerated from 0Hz to 01-09(P.20), the required time is defined as “deceleration time”.

Note: 1. S shape acceleration /deceleration curve 1 is used when acceleration/deceleration is required in a short time in high-speed area equal to or higher than the base frequency, such as spindle motor.
 2. S shape acceleration /deceleration curve 2 can effectively reduce motor vibration during the acceleration / deceleration, and thus prevent the belts and gears from failing.
 3. S shape acceleration /deceleration curve 3 is used to start the inverter gradually without impact.
 4. Please refer to Section 5.2.10 second function for the second acceleration/deceleration time.
 5. When RT is “on”, the second function is on. For the operation characteristics of the motor, please refer to Section 5.2.10 Second function. RT mentioned in this section is the function name of the “multi-function digital input terminal”. Please refer to 03-00(P.83)、03-01(P.84)、03-03(P.80)、03-04(P.81) for function selection and purposes of the multi-function digital input terminal. For related wiring, please refer to Section 3.7 Terminal wire arrangement.

5.2.4 Torque boost V/F

- For an inverter controlled by V/F mode, when the motor starts up, the starting torque is usually insufficient since the output voltage of the inverter is low. In this case, the output voltage can be elevated by setting the torque boost 01-10(P.0) properly, and thus getting a better starting torque.

Parameter	Name	Default	Setting Range	Content
01-10 P.0	Torque boost	6.0%	0 ~ 30.0%	0.75K and under
		4.0%		1.5K ~ 3.7K models
		3.0%		5.5K~7.5K/11KF models
		2.0%		11K/15KF and above model

Setting Torque boost

- ◆ If 01-10(P.0)=6% and 01-04(P.19)=220V, and when output frequency of the inverter is 0.2Hz, the output voltage is:

$$01-04(P.19) \times \left(\frac{100\% - 01-10(P.0)}{01-03(P.3)} \times f + 01-10(P.0) \right) = 220V \times \left(\frac{100\% - 6\%}{50Hz} \times 0.2Hz + 6\% \right) = 14.03V$$

- ◆ If RT is “on,” “the second torque boost” on 01-24(P.46) is valid (Note 2).

Note: 1. If the set value of 01-10(P.0) is too high, it will activate inverter over current protection and fail to start.
 2. Please refer to Section 5.2.10 for the second function.
 3. RT mentioned in this section is the function name of the “multi-function digital input terminal”. Please refer to 03-00(P.83), 03-01(P.84), 03-03(P.80), 03-04(P.81) for function selection of the multi-function digital input terminal. For related wiring, please refer to Section 3.7 Terminal wire arrangement.

5.2.5 Starting frequency

- When the motor starts up, the instantaneous output frequency of the inverter is called “starting frequency”.

Parameter	Name	Default	Setting Range	Content
01-11 P.13	Starting frequency	0.50Hz	0 ~ 60.00Hz	---

Setting Starting frequency

- ◆ If target frequency of inverter is lower than 01-11(P.13) value, the motor will not run. When given the start signal to motor, the output frequency will go up from the value of 01-11(P.13).

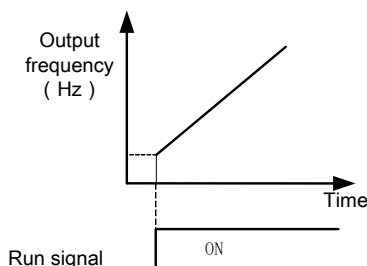

5.2.6 Load pattern selection V/F

➤ In V/F control, you can choose the best output characteristics for different applications and load.

Parameter	Name	Default	Setting Range	Content
01-12 P.14	Load selection pattern	0	0	For constant torque loads (conveyor belt, etc.)
			1	For variable torque loads (fans and pumps, etc.)
			2 ~ 3	For Lifting loads
			4	Multipoint V/F curve
			5 ~ 13	Special two-point V/F curve

Setting Load pattern selection

- ◆ When 01-12(P.14) = 4, suppose that 01-04(P.19)=220V, 01-26(P.98)=5Hz, 01-27(P.99)=10%, when the inverter is running at 5Hz, the output voltage equals to 01-04(P.19)×01-27(P.99) = 220V×10% = 22V.
- ◆ If RT is “on”, 01-24(P.46) “the second torque boost” is valid.

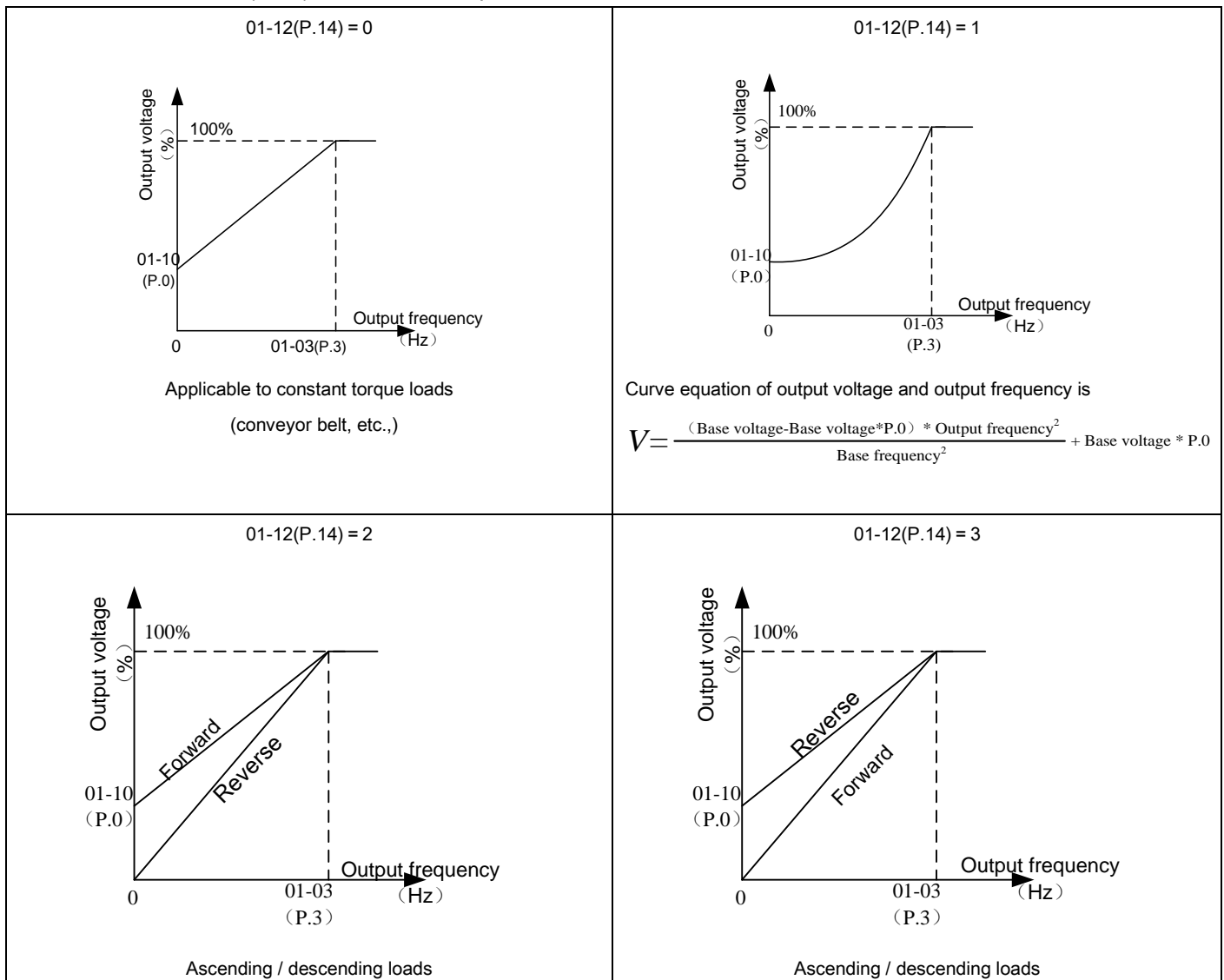

Basic Parameter Group 01

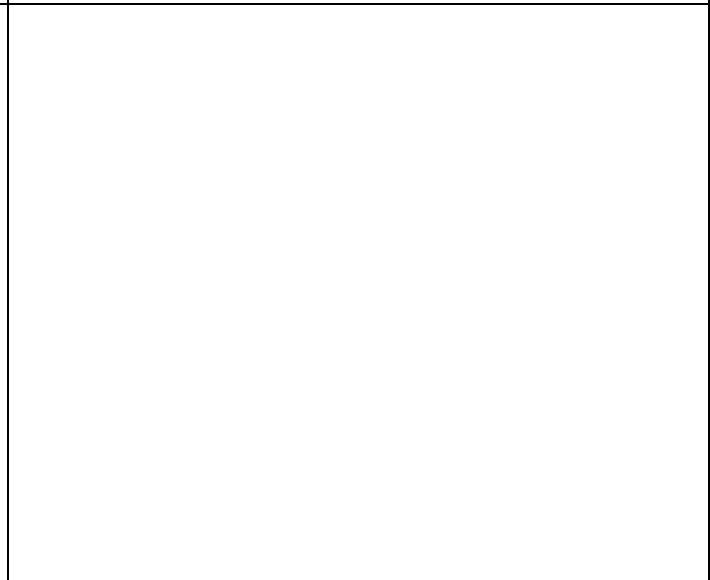
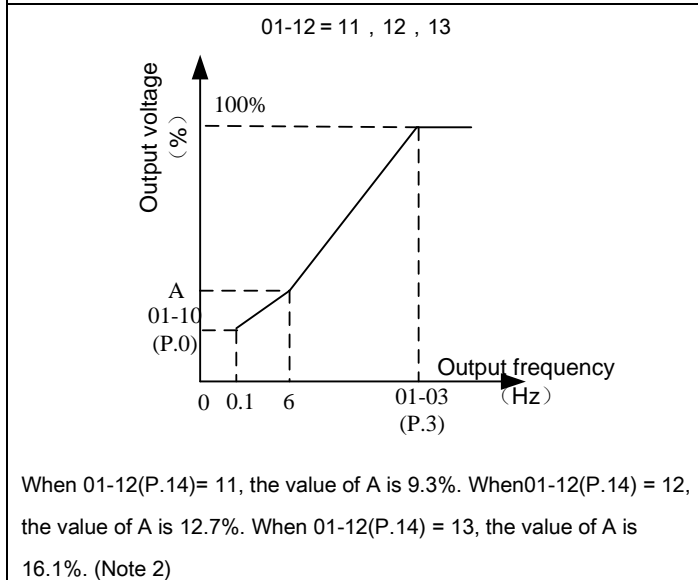
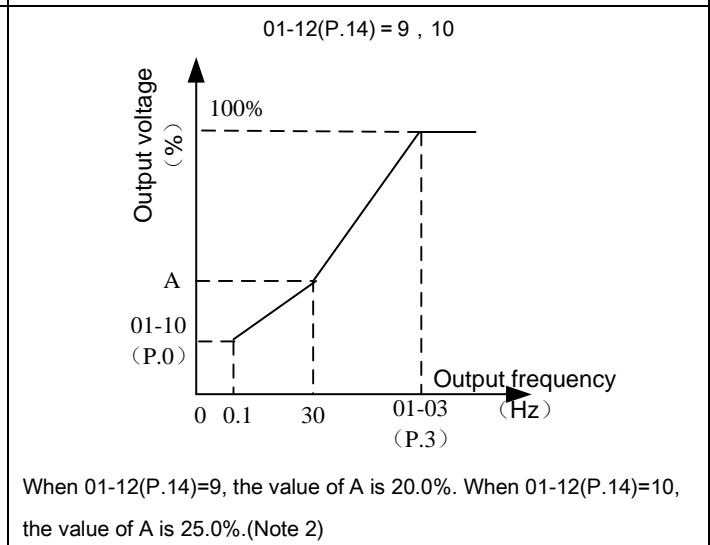
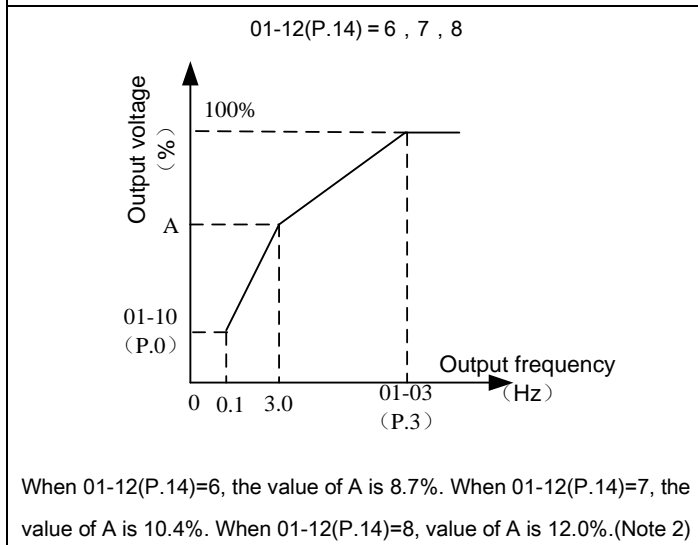
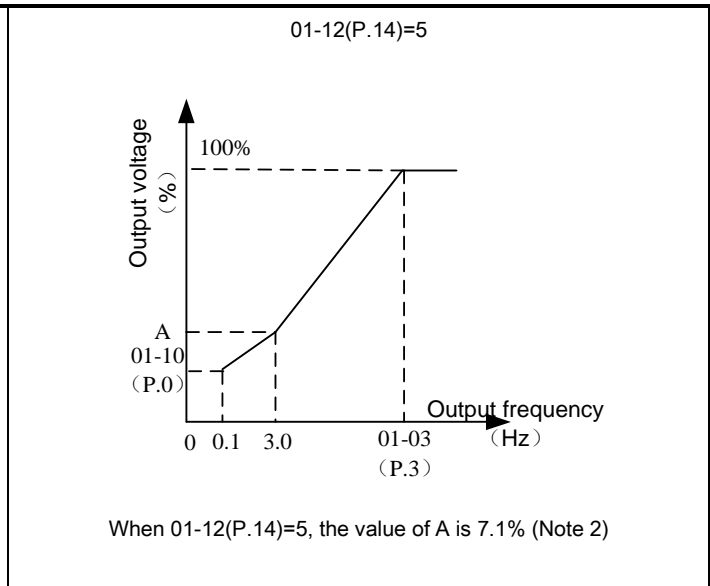
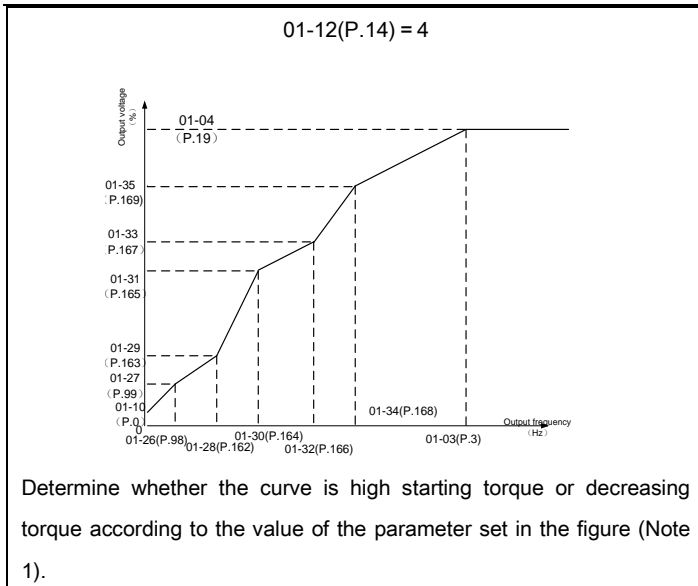

Note: 1. Referring to the diagrams above, set 01-26(P.98) and 01-27(P.99) if one point is needed. Set 01-26(P.98), 01-27(P.99), 01-28(P.162) and 01-29(P.163) if two points are needed. 01-26(P.98), 01-27(P.99), 01-28(P.162), 01-29(P.163), 01-30(P.164) and 01-31(P.165) if three points are needed.

2. When set 01-12(P.14) between 5 and 13, if 01-10(P.0) is larger than the point A, point A equals to 01-10(P.0).

5.2.7 JOG run

- The frequency and acceleration/deceleration time for JOG running can be set. JOG can be used for conveyor positioning, test run, etc.

Parameter	Name	Default	Setting Range	Content
01-13 P.15	JOG frequency	5.00Hz	0 ~ 650.00Hz	---
01-14 P.16	JOG Acc/ Dec time	0.50s	0 ~ 360.00s/ 0 ~ 3600.0s	01-08(P.21)=0/ 01-08(P.21)=1

Setting

JOG operation

- ◆ In JOG mode, the output frequency is the set value of 01-13(P.15), and the acceleration / deceleration time is the set value of 01-14(P.16).

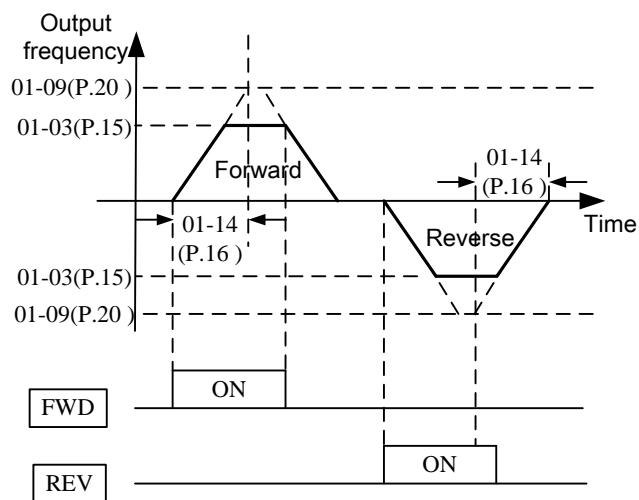

Note:1. Please refer to Section 4.3.3 Basic operation steps for JOG mode for how to enter the JOG mode.

5.2.8 Output frequency filter time

- This filter can reduce the impact when switching the frequency between high and low, and thus reduce the vibration of machine

Parameter	Name	Default	Setting Range	Content
01-15 P.28	Output frequency filter time	0	0 ~ 31	---

Setting Output frequency filter time

- ◆ The filtering effect is better when output frequency filter time is larger, but will also increase the response delay.
- ◆ If 01-15(P.28) is set to 0, the filtering function is off.

5.2.9 Frequency jump

- To avoid resonance from a mechanical system, these parameters allow jumping through resonant frequencies.

Parameter	Name	Default	Setting Range	Content
01-16 P.91	Frequency jump 1A	99999	0 ~ 650.00Hz	---
			99999	Invalid.
01-17 P.92	Frequency jump 1B	99999	0 ~ 650.00Hz	---
			99999	Invalid.
01-18 P.93	Frequency jump 2A	99999	0 ~ 650.00Hz	---
			99999	Invalid.
01-19 P.94	Frequency jump 2B	99999	0 ~ 650.00Hz	---
			99999	Invalid.
01-20 P.95	Frequency jump 3A	99999	0 ~ 650.00Hz	---
			99999	Invalid.
01-21 P.96	Frequency jump 3B	99999	0 ~ 650.00Hz	---
			99999	Invalid.

Setting Frequency jump

- ◆ To avoid system's mechanical resonance frequency when running the motor, the inverter provides three sets of jump frequencies: 01-16(P.91) and 01-17(P.92) (the first set), 01-18(P.93) and 01-19(P.94) (the second set), 01-20(P.95) and 01-21(P.96) (the third set)

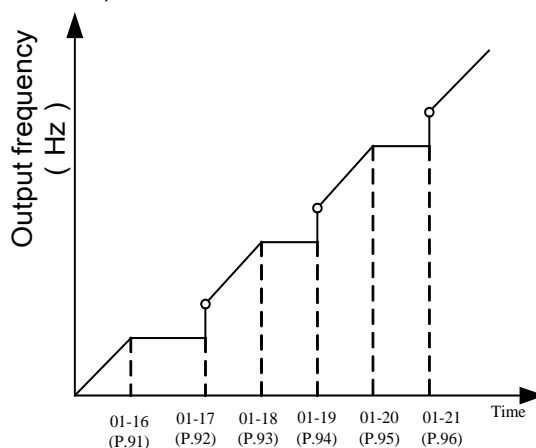

◆ For example: assuming 01-16(P.91)=45 and 01-17(P.92)=50;

If the target frequency \leq 45Hz, then the steady output frequency = the target frequency.

If 45Hz \leq target frequency $<$ 50Hz, then the steady output frequency = 45Hz.

If the target frequency \geq 50Hz, then the steady output frequency = the target frequency.

Note: 1. During acceleration / deceleration, output frequency of inverter will pass through the jump frequency.

2. When 01-16(P.91)=99999 or 01-17(P.92)=99999, the first set of frequency jump is invalid.

When 01-18(P.93)=99999 or 01-19(P.94)=99999, the second set of frequency jump is invalid.

When 01-20(P.95)=99999 or 01-21(P.96)=99999, the third set of frequency jump is invalid.

5.2.10 Second function

➤ When given RT signal, these parameters will work.

Parameter	Name	Default	Setting Range	Content
01-22 P.44	Second acceleration time	99999	0 ~ 360.00s/0 ~ 3600.0s	01-08(P.21)=0 / 01-08(P.21)=1
			99999	Off
01-23 P.45	Second deceleration time	99999	0 ~ 360.00s/0 ~ 3600.0s	01-08(P.21)=0 / 01-08(P.21)=1
			99999	Off
01-24 P.46	Second torque boost	99999	0 ~ 30.0%	---
			99999	Off
01-25 P.47	Second base frequency	99999	0 ~ 650.00Hz	---
			99999	Off

Setting Second function

- ◆ When 01-08(P.21)=0, minimum acceleration / deceleration time 01-22(P.44), 01-23(P.45) increment is 0.01s.
- ◆ When 01-08(P.21)=1, minimum acceleration / deceleration time 01-22(P.44), 01-23(P.45) increment is 0.1s.
- ◆ When RT is “on”, second function is valid. For the motor operation characteristics, please refer to the following second function setting.

If 01-22(P.44)≠99999 and 01-23(P.45)=99999, when RT is “on”, acceleration /deceleration time is the “set value of 01-22(P.44)”.

If 01-22(P.44)≠99999 and 01-24(P.46)=99999, when RT is “on”, torque boost is the “set value of 01-10(P.0)”.

If 01-22(P.44)≠99999 and 01-24(P.46)≠99999, when RT is “on”, torque boost is the “set value of 01-24(P.46)”.

If 01-22(P.44)≠99999 and 01-25(P.47)=99999, when RT is “on”, base frequency is the “set value of 01-03(P.3)”.

If 01-22(P.44)≠99999 and 01-25(P.47)≠99999, when RT is “on”, base frequency is the “set value of 01-25(P.47)”.

Note: RT mentioned here is the function name of “multi-function digital input terminal”. Please refer to 03-00(P.83), 03-01(P.84), 03-03(P.80), 03-04(P.81) for function selection of multi-function digital input terminal; please refer to Section 3.7 Terminal wire arrangement.

5.2.11 Middle frequency, output voltage of middle frequency V/F

➤ Parameters can be set when using special motors, especially to adjust motor torque.

Parameter	Name	Default	Setting Range	Content
01-26 P.98	Middle frequency 1	3.00Hz	0 ~ 650.00Hz	---
01-27 P.99	Output voltage 1 of middle frequency	10.0%	0 ~ 100.0%	---
01-28 P.162	Middle frequency 2	99999	0 ~ 650.00Hz	---
			99999	Off
01-29 P.163	Output voltage 2 of middle frequency	0.0%	0 ~ 100.0%	---
01-30 P.164	Middle frequency 3	99999	0 ~ 650.00Hz	---
			99999	Off
01-31 P.165	Output voltage 3 of middle frequency	0.0%	0 ~ 100.0%	---
01-32 P.166	Middle frequency 4	99999	0 ~ 650.00Hz	---
			99999	Off
01-33 P.167	Output voltage 4 of middle frequency	0.0%	0 ~ 100.0%	---
01-34 P.168	Middle frequency 5	99999	0 ~ 650.00Hz	---
			99999	Off
01-35 P.169	Output voltage 5 of middle frequency	0.0%	0 ~ 100.0%	---

Setting

Middle frequency, output voltage of middle frequency

◆ Please refer to the description for 01-12(P.14)=4 in Section 5.2.6 Load pattern selection.

5.2.12 S pattern time

➤ It is used to set the acceleration time of S pattern acceleration/deceleration.

Parameter	Name	Default	Setting Range	Content
01-36 P.255	S curve time at the beginning of acceleration	0.20s	0 ~ 25.00s/ 0 ~ 250.0s	01-08(P.21)=0/ 01-08(P.21)=1
01-37 P.256	S curve time at the end of acceleration	99999	0 ~ 25.00s/ 0 ~ 250.0s	01-08(P.21)=0/ 01-08(P.21)=1
			99999	Off
01-38 P.257	S curve time at the beginning of deceleration	99999	0 ~ 25.00s/ 0 ~ 250.0s	01-08(P.21)=0/ 01-08(P.21)=1
			99999	Off
01-39 P.258	S curve time at the end of deceleration	99999	0 ~ 25.00s/ 0 ~ 250.0s	01-08(P.21)=0/ 01-08(P.21)=1
			99999	Off

Setting S pattern time

◆ When 01-05(P.29) = 3, "S pattern acceleration /deceleration curve 3".

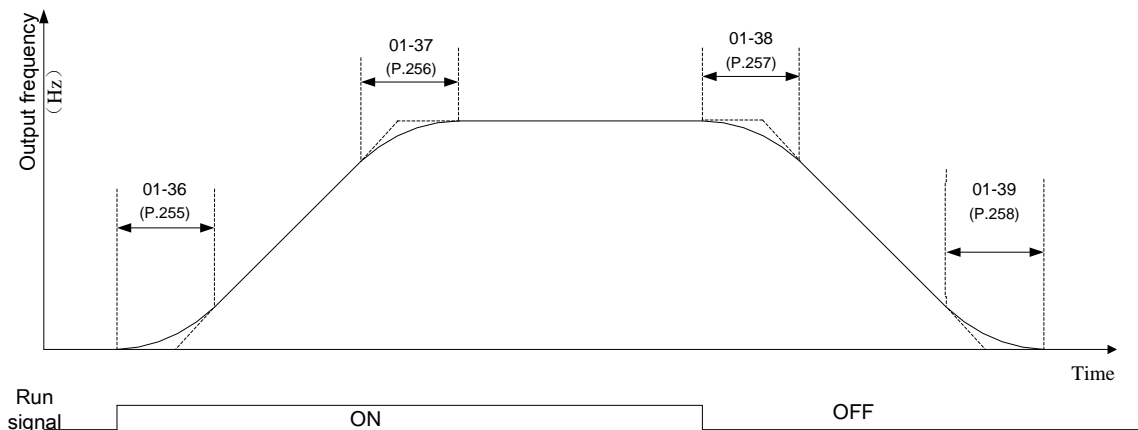

- Parameters 01-36(P.255), 01-37(P.256), 01-38(P.257) and 01-39(P.258) are used to start inverter gradually without impact. And adjust the value to vary degrees of S shape acceleration / deceleration curve. When the S shape acceleration / deceleration curve is started, the inverter will accelerate/decelerate with different speed according to the primary acceleration/deceleration time.
- When S shape acceleration/deceleration curve 3 is selected, the acceleration/ deceleration time will be longer, as follows
- When the selected acceleration time (01-06(P.7) or 01-22(P.44)) \geq 01-36(P.255) and 01-37(P.256), the actual acceleration time is as follows:
Actual acceleration time = the selected acceleration time +(01-36(P.255) + 01-37(P.256))/ 2
- When the selected deceleration time (01-07(P.8) or 01-23(P.45)) \geq 01-38(P.257) and 01-39(P.258), the actual deceleration time is as follows:
Actual deceleration time = the selected deceleration time +(01-38(P.257) + 01-39(P.258))/ 2

Example: when the parameters are in default value (60 Hz system), the actual acceleration time from stop state to 60Hz in accordance with S shape acceleration/deceleration curve 3 is as follows:

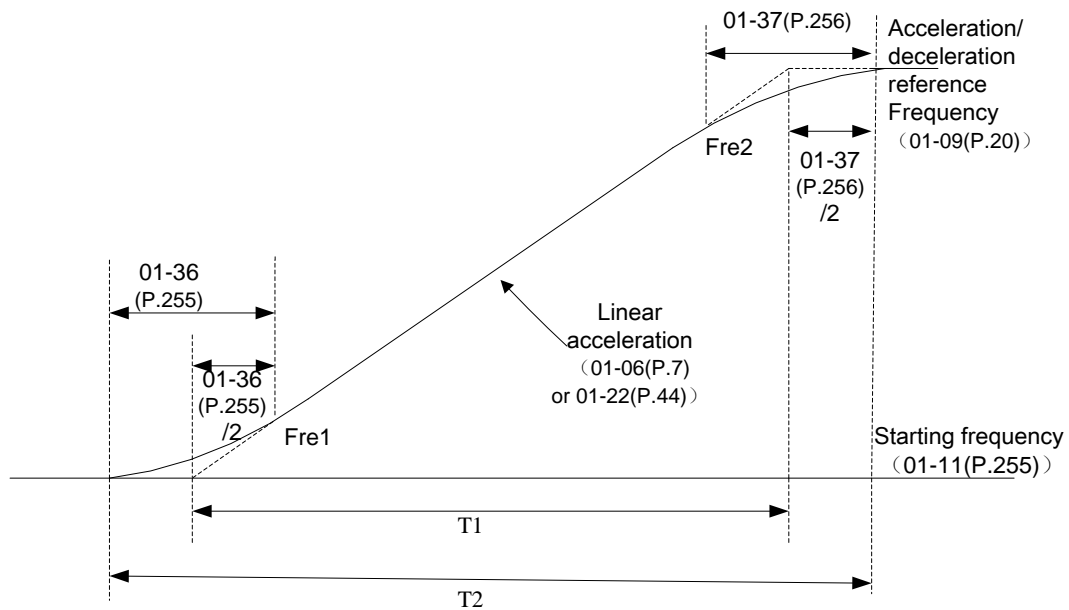

Set acceleration time $T1 = (01-09(P.20) - 01-11(P.13)) * 01-06(P.7) / 01-09(P.20)$

Actual acceleration time $T2 = T1 + (01-36(P.255) + 01-37(P.256)) * (01-09(P.20) - 01-11(P.13)) / 2 / 01-09(P.20)$

So $T1 = (60 - 0.5) * 5 / 60 = 4.96s$ (the actual acceleration time of linear acceleration)

Actual acceleration time $T2 = 4.96 + (0.2 + 0.2) * (60 - 0.5) / 2 / 60 = 5.16s$

Note: All calculations of acceleration/deceleration time are based on 01-09 (P.20).

5.2.13 Remote function acc/dec time selection

- Used to select the remote control function RM, RH to modify the acceleration and deceleration time of the remote control frequency.

Parameter	Name	Default	Setting Range	Content
01-40	Remote function	0	0	Use default acc/dec time (same as regular mode)
P.219	acc/dec time selection		1	Use second acc/dec time

Setting

Remote control frequency acceleration and deceleration time selection

- ◆ 01-40 (P.219) = 0, the acceleration and deceleration time of the remote control frequency is the current acceleration and deceleration time (the same as the acceleration and deceleration time of the output frequency);
- ◆ When 01-40 (P.219) = 1,
 - If 01-22 (P.44) ≠ 99999 , 01-23 (P.45) = 99999 , The acceleration time and deceleration of the remote control frequency are both "01-22 (P.44) set value" ;
 - If 01-22 (P.44) ≠ 99999 , 01-23 (P.45) ≠ 99999 , The acceleration time of the remote control frequency is "01-22 (P.44) setting value", and the deceleration time is "01-23 (P.45) setting value" ;
 - If 01-22 (P.44) = 99999 , the acceleration and deceleration time of the remote control frequency is the current acceleration and deceleration time (the same as the acceleration and deceleration time of the output frequency)

5.3 Analog input and output parameter group 02

Group	Parameter Number	Name	Setting Range	Default	Page
02-06	P.185	Proportional linkage gain	0 ~ 100%	0%	79
02-07	P.240	Auxiliary frequency	0: Off	0	79
			2: Output frequency = basic frequency + auxiliary frequency (given by terminal 3-5)		
			4: Output frequency = basic frequency - auxiliary frequency (given by terminal 3-5)		
			6: Output frequency = proportional linkage signal (given by terminal 3-5)		
02-10	P.60	Terminal 3-5 filter time	0 ~ 2000ms	31ms	80
02-20	P.17	Terminal 3-5 signal range selection	0: Signal sampling range from 4~20mA.	1	80
			1: Signal sampling range from 0 ~ 10V.		
			2: Signal sampling range from 0 ~ 5V.		
02-21	P.39	Terminal 3-5 maximum operation frequency	50Hz system:1.00 ~ 650.00Hz	50.00Hz	80
			60Hz system:1.00 ~ 650.00Hz	60.00Hz	
02-24	P.184	Terminal 3-5 disconnect selection	0: Off	0	80
			1: Inverter decelerates to 0Hz, multi-function digital output terminal set off alarm		
			2: Inverter stops immediately, and keypad displays "AErr" alarm		
			3: Inverter runs continuously according to the frequency command before disconnection. Digital output terminal will set off alarm.		
02-25	P.198	Terminal 3-5 minimum input current/ voltage	0 ~ 20.00 mA /V	0.00V	80
02-26	P.199	Terminal 3-5 maximum input current/ voltage	0 ~ 20.00 mA/ V	10.00V	80
02-27	P.196	Percentage corresponds to terminal 3-5 minimum input current/ voltage	0% ~ 100.0%	0.0%	80
02-28	P.197	Percentage corresponds to terminal 3-5 maximum input current/ voltage	0% ~ 100.0%	100.0%	80
02-52	P.56	Inverter rated current display level	0~500.00A	According to model	85
02-61	P.141	Polarity of percentage corresponds to terminal 3-5 current/ voltage signal	0~11	0	80

5.3.1 Proportional linkage gain

- This function is used to multiply frequency command from external analog input terminal. When multiple inverters are running in proportion, it is effective to use this function to fine-tune the frequency command from master inverter to slave inverter.

Parameter	Name	Default	Setting Range	Content
02-06 P.185	Proportional linkage gain	0%	0 ~ 100%	---

Setting

Proportional linkage gain

- ◆ When output frequency is lower than 01-01(P.2), it is equal to lower limit frequency 01-01(P.2). When output frequency is higher than 01-00(P.1), it is equal to upper limit frequency 01-00(P.1).
- ◆ After multiplying the setting frequency by 02-06(P.185) value, add and subtract can be performed as follows:
For example: When the setting frequency is 50Hz, 02-06(P.185)=50% and the external analog input signal is 0~10V.

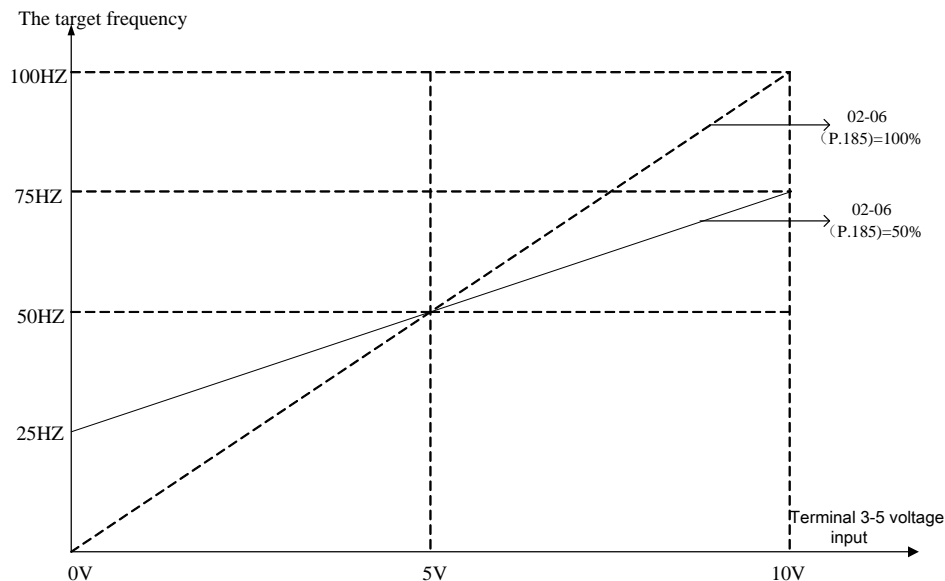

In the above figure, when 0V is given, the target frequency is $50\text{Hz} - (50\text{Hz} \times 50\%) = 25\text{Hz}$;

when 5V is given, the target frequency is $50\text{Hz} - (50\text{Hz} \times 0\%) = 50\text{Hz}$;

when 10V is given, the target frequency is $50\text{Hz} + (50\text{Hz} \times 50\%) = 75\text{Hz}$.

Note: 1. For proportional linkage signal input, please refer to the description of parameter 02-07 (P.240).

2. When use terminal 3-5 analog (voltage/current) signal as proportional linkage signal input terminal, please refer to parameter 02-20(P.17) ; for the setting of external analog signal frequency range, please refer to parameter 02-21(P.39).

5.3.2 Auxiliary frequency

- Frequency can be adjusted and synthesized flexibly to meet the different control requirements in different scenarios.

Parameter	Name	Default	Setting Range	Content
02-07 P.240	Auxiliary frequency	0	0	Off
			2	Output frequency = basic frequency + auxiliary frequency (given by terminal 3-5)
			4	Output frequency = basic frequency - auxiliary frequency (given by terminal 3-5)
			6	Output frequency = proportional linkage signal (given by terminal 3-5)

Setting Auxiliary frequency

- ◆ When output frequency is lower than 01-01(P.2), it equals to lower limit frequency 01-01(P.2). When output frequency is higher than 01-00(P.1), it equals to upper limit frequency 01-00(P.1).

Note: 1. Basic frequency command is given by keypad, communication or multi-speed terminal.

2. For proportional linkage signals, please refer to the description of parameter 02-06(P.185).

3. When use terminal 3-5 analog (voltage/current) signal as proportional linkage signal input terminal, please refer to parameter 02-20(P.17). For the setting of external analog signal frequency range, please refer to parameter 02-21(P.39).

5.3.3 Terminal 3-5 signal selection and processing

- Select terminal 3-5 signal specification and frequency compensation function.

Parameter	Name	Default	Setting Range	Content
02-10 P.60	Terminal 3-5 filter time	31ms	0 ~ 2000ms	---
02-20 P.17	Terminal 3-5 signal range selection	1	0	Signal sampling range from 4~20mA.
			1	Signal sampling range from 0 ~ 10V.
			2	Signal sampling range from 0 ~ 5V.
02-21 P.39	Terminal 3-5 maximum operation frequency	50.00Hz	1.00 ~ 650.00Hz	50Hz system (00-24(P.189)=1)
		60.00Hz		60Hz system (00-24(P.189)=0)
02-24 P.184	Terminal 3-5 disconnect selection	0	0	Off
			1	Inverter decelerates to 0Hz, multi-function digital output terminal set off alarm
			2	Inverter stops immediately, and keypad displays "AErr" alarm
			3	Inverter runs continuously according to the frequency command before disconnection. Digital output terminal will set off alarm.
02-25 P.198	Terminal 3-5 minimum input current/ voltage	0.00V	0 ~ 20.00mA/V	---

Parameter	Name	Default	Setting Range	Content
02-26 P.199	Terminal 3-5 maximum input current/ voltage	10.00V	0 ~ 20.00mA/V	---
02-27 P.196	Percentage corresponds to terminal 3-5 minimum input current/ voltage	0.0%	0% ~ 100.0%	---
02-28 P.197	Percentage corresponds to terminal 3-5 maximum input current/ voltage	100.0%	0% ~ 100.0%	---
02-61 P.141	Polarity of percentage corresponds to terminal 3-5 current/ voltage signal	0	0~11	---

Setting Terminal 3-5 signal selection, maximum input

- ◆ The setting value of 02-21 (P.39) is the target frequency value of the inverter when the input signal of terminal 3-5 is at 20mA (5V/10V).

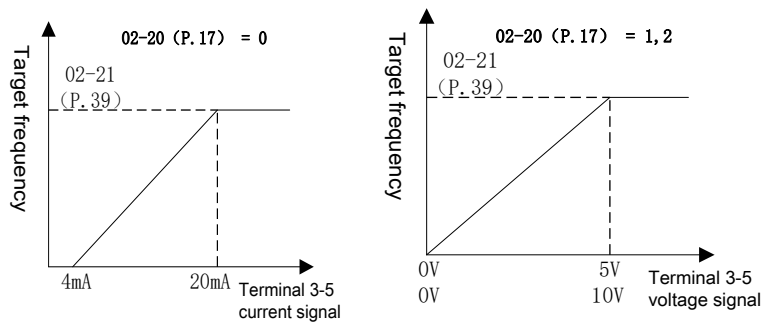

Setting Terminal 3-5 input signal processing

- ◆ Parameters above define the relationship between analog input voltage and set value in analog input. When analog input voltage exceeds maximum or minimum range of the set value, the excess part will be calculated as maximum and minimum input.
- ◆ There are two setting steps when setting maximum and minimum percentage:
 - 1) If users want to adjust the analog input to correspond with a certain type of proportional relationship, Adjust the analog input first and then set the corresponding proportional parameter. Inverter will calculate it by itself, don't need to set the voltage parameter (refer to Example 1.1).
 - 2) If users skip the adjustment of analog input and set proportional relationship directly, first set proportional parameter then set voltage parameters (refer to Example 1.2).

Example 1.1: User adjusts analog input voltage to minimum value A and sets parameter 02-27(P.196) adjusts input voltage to maximum value B, and sets parameter 02-28(P.197) . As shown below:

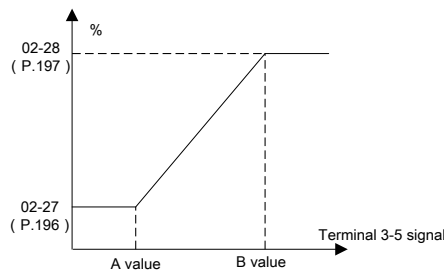

Example 1.2: Set 02-27(P.196) and 02-28(P.197) value, then set 02-25(P.198) and 02-26(P.199). Figure is shown as follows:

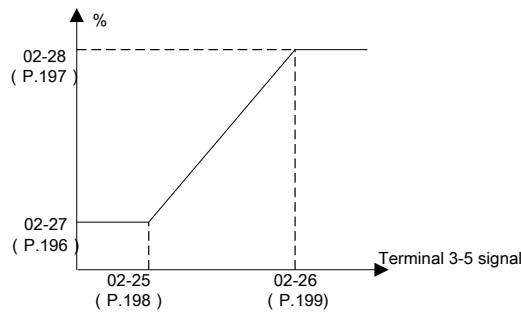

If the external analog frequency is selected, the ratio calculated according to the figure above is multiplied by 02-21 (P.39) to be the actual frequency input value (terminal 3-5 current/voltage input corresponding percentage selections are all positive 02-61(P.141) = 0).

Setting

Polarity of percentage corresponds to terminal 3-5 current/ voltage signal

- ◆ The setting of parameter 02-61 (P.141) is set in bits, a total of 2 bits, the meaning of each bit is as follows:

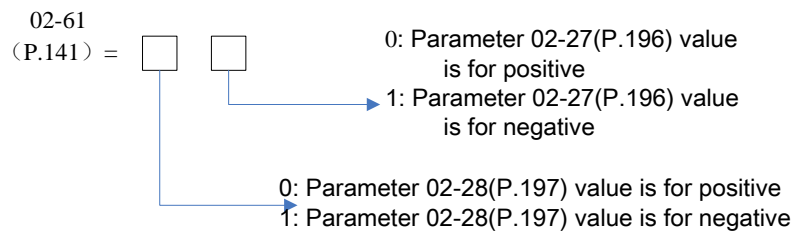

If the input percentage of the given current/voltage is negative, the inverter runs in the reverse direction of the given running direction.

- ✓ Some application examples of terminal 3-5

Example 1: This example is the most commonly used method. It is used when inverter is in “external mode”, “combined mode 2”or “combined mode 4”, and frequency command is given by terminal 3-5.

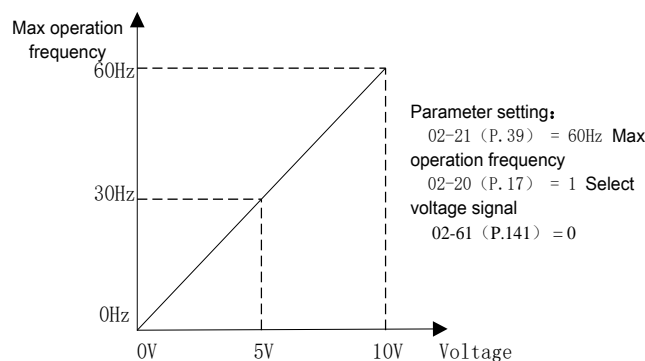

Example 2: This example is for users who need the motor to run at 10Hz when the potentiometer is turned to the left end. All frequencies above 10Hz can still be adjusted by the user freely.

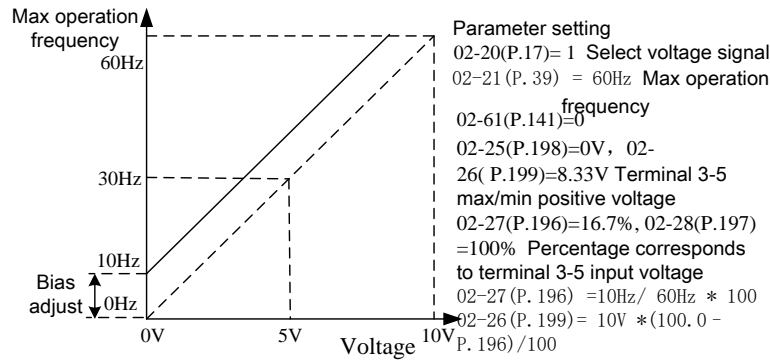

Example 3: This example is also frequently used by the industry. The comprehensive usage for all domain of the potentiometer setup elevates the flexibility.

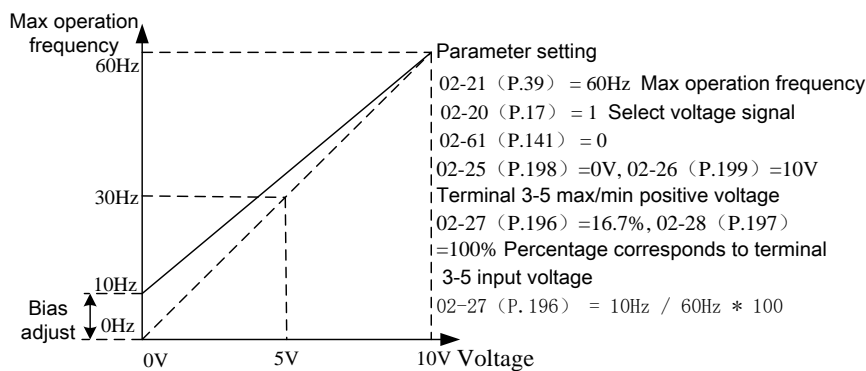

Example 4: This example uses 0~5V to give frequency command.

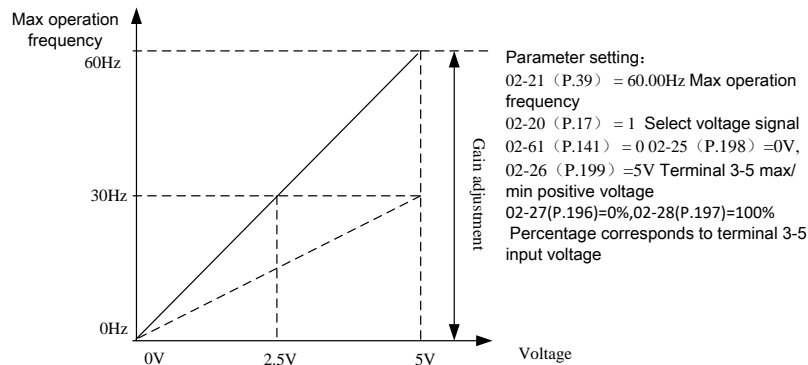

Example 5: This example is used to avoid signal below 1V given to inverter as running frequency in harsh environment, which can greatly avoid the interference of noise.

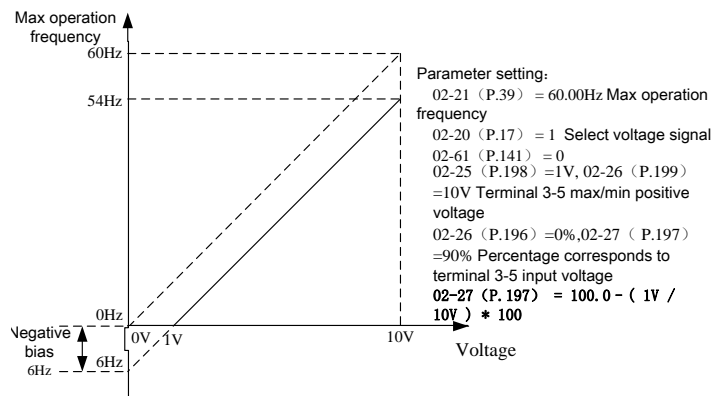

Example 6: This example is an extension of Example 5. This kind of application is open, user can apply flexibly.

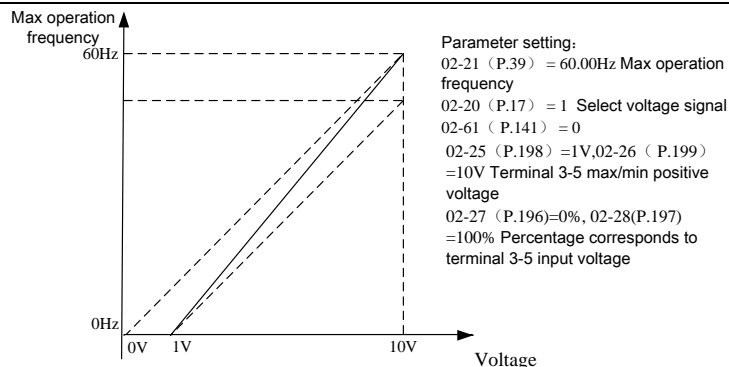

Example 7: This example is an application of inverse slope setting. The industry often uses sensors for pressure, temperature or flow control. Some of the sensors output 10V signal at high voltage or high flow. This signal acts as a reference for the inverter to decelerate or to stop. The setup presented in Example 7 can satisfy this type of application.

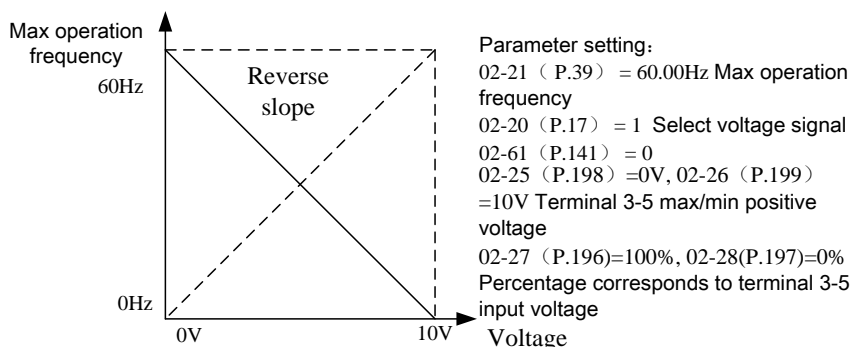

Example 8: This example integrates all the application of potentiometer. Together with the application of forward and reverse rotation, it fits in the system easily for complicated application.

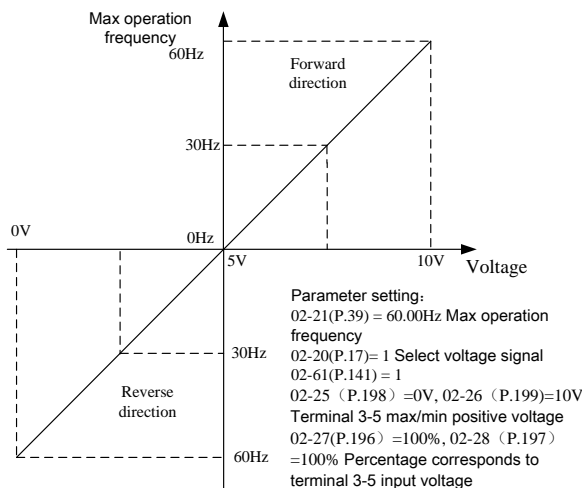

Note: 1. In the "external mode" or "combined mode 2" or "combined mode 4", the target frequency of the inverter is determined by the 3-5 terminal signal.

2. In "external mode" or "combined mode 2" or "combined mode 4", if any of RH, RM, RL or REX is "on", at the same time, the target frequency of the inverter will be given priority to multi-speed.

3. The RH, RM, RL, and REX mentioned in this paragraph are the function names of "multi-function digital input terminals". For the function selection and function of the multi-function digital input terminal, please refer to 03-00 (P.83), 03-01 (P.84), 03-03 (P.80), 03-04 (P.81); For wiring, please refer to section 3.7 Terminal wire arrangement.

4. Terminal 3-5 analog signal can be given either voltage or current, which is determined by 02-20 (P.17) and AVI-ACI switch function.

◆ Terminal 3-5 disconnect function

- 1) If 02-24(P.184) = 0, after disconnection, inverter will slow down to 0Hz, and after reconnection, the inverter will accelerate to current given frequency.
- 2) If 02-24(P.184) =1 after disconnection, the keypad will display “AErr” alarm, inverter will slow down to 0Hz and at the same time multi-function digital output terminal will set off an alarm; after reconnection, alarm will be released and the inverter will accelerate to the current given frequency.
- 3) If 02-24(P.184) =2 after disconnection, the keypad will display “AErr” alarm, inverter will stop immediately, and reset is required to release the alarm.
- 4) If 02-24(P.184) =3 after disconnection, the keypad will display “AErr” alarm, the inverter will continue to run according to the frequency command before disconnection, the multi-function digital output terminal will set off an alarm, which will be released after reconnection.

Note: When 02-20(P.17)=1, 2, terminal 3-5 is voltage signal setting, this disconnection function will be invalid.

◆ Terminal 3-5 current/voltage input

Terminal 3-5 cannot receive negative voltage and the minimum input is 4mA when selecting current input.

Note: The function of terminal 3-5 here must first switch AVI-ACI to the corresponding position and then make sure it matches the setting value of 02-20 (P.17).

5.3.4 Inverter rated current display level

➤ It is used to set the display reference when output current.

Parameter	Name	Default	Setting Range	Content
02-52 P.56	Inverter rated current display level	Note	0 ~ 500.00A	---

 Setting Display level

◆ Used for inverter current output display.

Note: The default value of parameter 02-52 (P.56) is determined by the model.

5.4 Digital input/ output parameter group 03

Group	Parameter Number	Name	Setting Range	Default	Page
03-00	P.83	Terminal STF input function	0: STF(Inverter runs forward)	0	90
			1: STR(Inverter runs reverse)		
			2: RL(Multi-speed low speed)		
			3: RM(Multi-speed medium speed)		
			4: RH(Multi-speed high speed)		
			5: Reserved		
			6: External thermal relay actuate		
			7: MRS(Stops inverter output immediately)		
			8: RT(Inverter second function)		
			9: EXJ(External JOG)		
			10 : STF+EXJ		
			11 : STR+EXJ		
			12 : STF+RT		
			13 : STR+RT		
			14 : STF+RL		
			15 : STR+RL		
			16 : STF+RM		
			17 : STR+RM		
			18 : STF+RH		
			19 : STR+RH		
			20 : STF+RL+RM		
			21 : STR+RL+RM		
			22 : STF+RT+RL		
			23 : STR+RT+RL		
			24 : STF+RT+RM		
			25 : STR+RT+RM		
			26 : STF+RT+RL+RM		
			27 : STR+RT+RL+RM		
			28: RUN(Inverter runs forward)		
			29: STF/STR(use with RUN signal, when ON, motor runs reverse ; when OFF, motor runs forward)		
			30: RES(External reset function)		
			31: STOP(Use as three line control with RUN signal and STF-STR signal)		
			32: REX(Extend multi-speed to 16 levels)		
			33: PO(In "external mode", run programmed operation)		
			34: RES_E (External reset, valid only when alarm.)		
			35: MPO (In "external mode" run manual cycle operation.)		
36: TRI(Triangle wave function)					

Group	Parameter Number	Name	Setting Range	Default	Page
03-00	P.83	Terminal STF input function	37~38 : Reserved	0	90
			39: STF/STR +STOP (Use with RUN signal, when ON, motor runs reverse, when OFF, motor stops then runs forward.)		
			40: P_MRS (Stops inverter output immediately by pulse signal input)		
			41~42 : Reserved		
			43: RUN_EN (Enable digital input terminal operation)		
			44: PID_OFF (Enable digital input terminal turning off PID)		
			45: Second frequency command source mode		
			46~91:Reserved		
			92:Fire mode command 1(RUN command included)		
			93:Fire mode command 2(RUN command excluded)		
03-01	P.84	Terminal STR input function	Same as 03-00	1	90
03-03	P.80	Terminal M0 input function	Same as 03-00	2	90
03-04	P.81	Terminal M1 input function	Same as 03-00	3	90
03-11	P.85	Terminal A-C output function	0: RUN(Output when inverter running)	5	93
			1: SU(Output when reach target frequency)		
			2: FU(Output when reach 03-21 03-22 value)		
			3: OL(Output when overload)		
			4: OMD(Output when output current is zero)		
			5: ALARM(Output when alarm)		
			6: PO1(Output when in program operation step)		
			7: PO2(Output when in program operation cycle)		
			8: PO3(Output when in program operation pause)		
			9~10 : Reserved		
			11 : OMD1(Output when output current is zero 1)		
			12 : OL2(Output when over torque)		
			13 ~ 16 : Reserved		
			17: RY(Output when inverter is powered on and no alarm)		
			18: Output when it's time for maintenance		
			19~40 : Reserved		
41 : PID feedback disconnection (AErr) alarm					
42:Fire mode indication					
03-14	P.87	Digital input logic	0 ~ 15	0	94
03-15	P.88	Digital output logic	0 : Terminal A-C output positive logic	0	94
			2 : Terminal A-C output negative logic		
03-16	P.120	Output signal delay time	0 ~ 3600.0s	0.0s	95

Digital input/ output parameter group 03

Group	Parameter Number	Name	Setting Range	Default	Page
03-17	P.157	Digital input terminal filter time	0 ~ 2000	4	95
03-18	P.158	Digital input terminal enable when power on	0: When power on digital terminals work directly	0	96
			1: When power on digital terminals work after switch off then on		
03-20	P.41	Output frequency detection sensitivity	0 ~ 100.0%	10.0%	96
03-21	P.42	Output frequency detection for forward rotation	0 ~ 650.00Hz	6.00Hz	96
03-22	P.43	Output frequency detection for reverse rotation	0 ~ 650.00Hz	99999	96
			99999: Same as the setting of 03-21(P.42)		
03-23	P.62	Zero current detection level	0 ~ 200.0%	5.0%	97
			99999: Off		
03-24	P.63	Zero current detection time	0.05 ~ 100.00s	0.50s	97
			99999: Off		

5.4.1 Digital input terminals function selection

- Use the following parameters to change the digital input terminal functions. Each terminal may choose any function between 0 ~ 45 (Note 1)

Parameter	Name	Default	Setting Range	Content
03-00 P.83	Terminal STF input function	0	0	STF(Inverter runs forward)
			1	STR(Inverter runs reverse)
			2	RL(Multi-speed low speed)
			3	RM(Multi-speed medium speed)
			4	RH(Multi-speed high speed)
			5	Reserved
			6	OH(External thermal relay actuate)
			7	MRS(Stops inverter output immediately)
			8	RT(Inverter second function)
			9	EXJ(External JOG)
			10	STF+EXJ
			11	STR+EXJ
			12	STF+RT
			13	STR+RT
			14	STF+RL
			15	STR+RL
			16	STF+RM
			17	STR+RM
			18	STF+RH
			19	STR+RH
			20	STF+RL+RM
			21	STR+RL+RM
			22	STF+RT+RL
			23	STR+RT+RL
			24	STF+RT+RM
			25	STR+RT+RM
			26	STF+RT+RL+RM
			27	STR+RT+RL+RM
			28	RUN(Inverter runs forward)
			29	STF/STR(use with RUN signal, when ON, motor runs reverse ; when OFF, motor runs forward)
			30	RES(External reset function)
			31	STOP(Use as three line control with RUN signal and STF-STR signal)
			32	REX(Extend multi-speed to 16 levels)
33	PO(In "external mode", run programmed operation)			
34	RES_E (External reset, valid only when alarm.)			
35	MPO (In "external mode" run manual cycle operation.)			
36	TRI(Triangle wave function)			
37~38	Reserved			

Digital input/ output parameter group 03

Parameter	Name	Default	Setting Range	Content
03-00 P.83	Terminal STF input function	0	39	STF/STR +STOP (Use with RUN signal, when ON, motor runs reverse, when OFF, motor stops then runs forward.)
			40	P_MRS (Stops inverter output immediately by pulse signal input)
			41~42	Reserved
			43	RUN_EN (Enable digital input terminal operation)
			44	PID_OFF (Enable digital input terminal turning off PID)
			45	Second frequency command source mode
			46~91	Reserved
			92	Fire mode command 1(RUN command included)
93	Fire mode command 2(RUN command excluded)			
03-01 P.84	Terminal STR input function	1	Same as 03-00	Same as 03-00
03-03 P.80	Terminal M0 input function	2	Same as 03-00	Same as 03-00
03-04 P.81	Terminal M1 input function	3	Same as 03-00	Same as 03-00



Digital input terminals function selection

- ◆ In default, 03-03(P.80)=2 (RL), 03-04(P.81)=3 (RM), 03-00(P.83)=0 (STF), 03-01(P.84)=1 (STR) .
- ◆ Changing terminal input function values change the function of the terminals. For example, 03-03(P.80)=2 means that M0 terminal acts as RL. If 03-03(P.80) is set to 8, M0 terminal function will change to RT, which will act as “second function”. Another example, 03-00(P.83)=0 means that STF terminal serves as “inverter runs forward” function, and if change 03-00(P.83) to 6, STF terminal function will change to OH, which will serve as the input terminal of external thermal relay
- ◆ Set value:6 OH(External thermal relay):
Old motors usually come with thermal relay attached to the front of the motor to prevent motor from overheating. When external thermal relay actuate, inverter will alarm and show “OHT” on keypad.
- ◆ Four different wiring techniques (1 means ON, 0 means Off, and X = 0 , 1 , 3 , 4)

1) Two-wire control mode 1:

K0	K1	Run command
0	0	Stop
1	0	Forward
0	1	Reverse
1	1	Stop

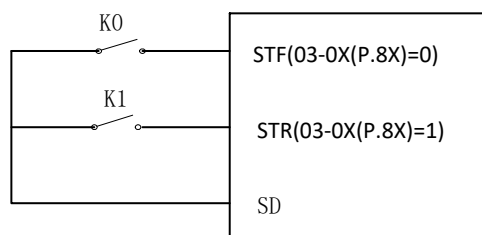

2) Two-wire control mode 2:

K0	K1	Run command
0	0	Stop
0	1	Stop
1	0	Forward
1	1	Reverse

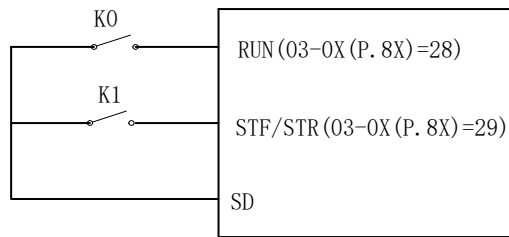

3) Three-wire control mode 1 (with seal-in function): K0 is STOP, normal close. When trigger inverter will stop. K1 is forward and K2 is reverse, normal open. All K0 K1 K2 are edge trigger button.

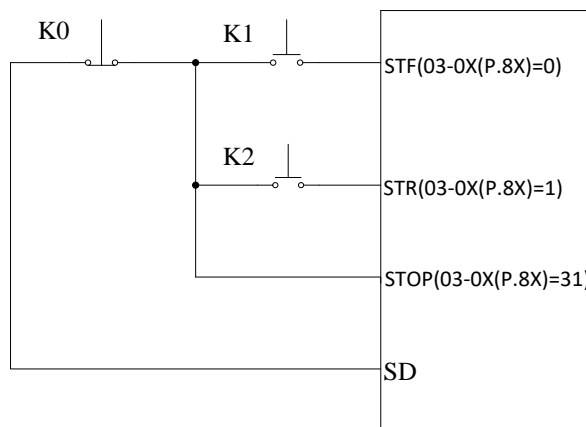

4) Three-wire control mode 2 (with seal-in function): K1 is STOP, normal close. When trigger inverter will stop. K2 is RUN, normal open. K1 K2 are edge trigger buttons. Change direction by STF/STR terminal, set value: 39. When changing the direction, stop the inverter first, then switch K0 state and start inverter again.

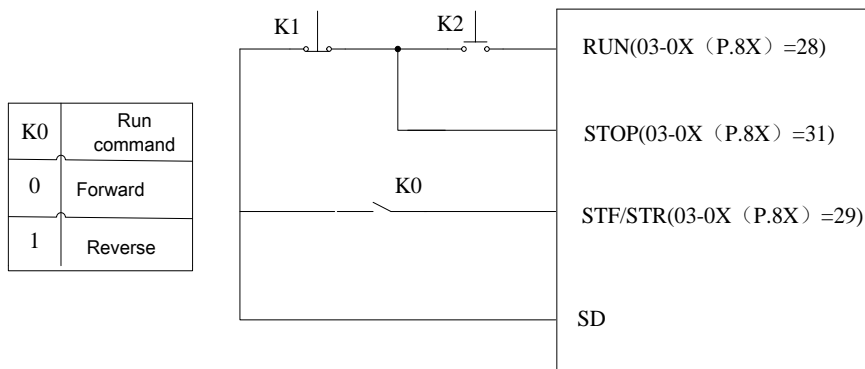

◆ Set value: 33 PO(programmed operation):

When in external mode and PO is ON, inverter will be in programmed operation mode. Terminal STF is start. When STF is ON, inverter run programmed operation mode at the first section. When STF is OFF, inverter stop. Terminal STR is pause. When STR is ON, pause the operation. When STR is OFF, operation continues from section before pausing. For details, please refer to 04-15(P.100), 04-27~04-42(P.101~P.118), 04-16~04-26 (P.121~P.123, P.131~P.138).

◆ Set value: 35 MPO(manual programmed operation):

In external mode, when MPO is "on" run manual cycle operation. For details, please refer to 04-19~04-26 (P.131~P.138).

- ◆ Set value : 45 Second frequency source mode
When this terminal is on, target frequency is set by 00-17(P.97).
- ◆ Fire mode command 1(RUN command included)
When in fire mode(06-84(P.207) = XXX1 or XXX2), if the terminal with related function is ON, the inverter goes into fire mode and starts compulsorily.
- ◆ Fire mode command 2(RUN command excluded)
When in fire mode (06-84(P.207) = XXX1 or XXX2), if the terminal with related function is ON, the inverter goes into fire mode.
When the inverter stopped, if the terminal with related function is ON, the inverter goes into fire mode, but not in running status.
When the inverter is in running status, if the terminal with related function is ON, the inverter runs base on the set parameter.

5.4.2 Digital output terminals function selection

- Detect some information that occurs during the operation of the inverter.

Parameter	Name	Default	Setting Range	Content
03-11 P.85	Terminal A-C output function	5	0	RUN(Output when inverter running): Output signal when inverter run above starting frequency
			1	SU(Output when reach target frequency): Output signal when the output frequency reaches target frequency
			2	FU (Output when reach certain frequency) : Output signal when detecting operation above specified frequency
			3	OL (Output when overload) : Output signal when current limit function is activated
			4	OMD(Output when output current is zero) : When the output current of the inverter is lower than the set value in 03-23 (P.62) for a period of time (03-24 (P.63)), OMD will output a signal
			5	ALARM (Output when alarm)
			6	PO1 (Output when in program operation step)
			7	PO2 (Output when in program operation cycle)
			8	PO3 (Output when in program operation pause)
			9~10	Reserved
			11	OMD1(Output when output current is zero 1) : When the output frequency of the inverter reaches the target frequency and the output current is lower than the setting value in 03-23 (P.62) for a period of time (setting of 03-24 (P.63)), OMD1 will output a signal
			12	OL2(Output when over torque) : If 06-10 (P.260)=1, when the over-torque signal is output, inverter will alarm OL2 and stop running; if 06-10 (P.260)=0, when the over-torque signal is output, the inverter will not alarm OL2 and continues to run.
			13 ~ 16	Reserved
			17	RY(Output when inverter is powered on and no alarm)
			18	Output when it's time for maintenance
19-40	Reserved			
41	PID feedback disconnection (AErr) alarm			
42	Fire mode indication			

Setting

Digital output terminals function selection

- ◆ Terminal A-C default value 03-11(P.85) is 5 which means "ALARM". If 03-11(P.85) value is changed, terminal function will change as shown in table above.

5.4.3 Terminal logic selection

- The function is bits-setting, if the bit shows 1, it means that the action of multi-function digital input terminal is negative logic; otherwise, it means that the action is positive logic.

Parameter	Name	Default	Setting Range	Content
03-14 P.87	Digital input logic	0	0 ~ 15	---
03-15 P.88	Digital output logic	0	0	Terminal A-C output positive logic
			2	Terminal A-C output negative logic

Setting Digital input/output logic

- ◆ The definition of each bit of 03-14(P.87) is as follows:

bit	2^3	2^2	2^1	2^0
	M1	M0	STR	STF

For example: A three-wire control type needs the function of STOP to be kept open (negative logic). So if set 03-03(P.80)=31, take M0 terminal as three-wire control STOP function, and 03-03(P.80)=0, 03-01(P.84)=1, and take STF and STR terminals as default positive/negative logic function, the parameter of 03-14(P.87) should be set as follows:

bit	2^3	2^2	2^1	2^0
	0	1	0	0

$$\text{So } (03-14)P.87 = 0 \times 2^3 + 1 \times 2^2 + 0 \times 2^1 + 0 \times 2^0 = 4$$

- ◆ The usage of 03-15(P.88) :

For example: 03-11(P.85)=0 (inverter is running and detecting), if set 03-15(P.88) to 0 (positive logic), when inverter runs, multi-relay is on. When inverter stops, multi-relay is off; if set 03-15(P.88) to 2 (negative logic), when inverter runs, multi-relay is off, and when the inverter stops, multi-relay is on.

Note: When “STF” and “STR” terminals are set as negative logic, but signal is not connected with SD, with power on, inverter will output and drive motor. So it is dangerous, please pay attention to it.

5.4.4 Digital output signal delay

- This parameter is used to delay and confirm the digital output signal. Delay time acts like confirmation time, which can prevent some unknown interference.

Parameter	Name	Default	Setting Range	Content
03-16 P.120	Output signal delay time	0.0s	0 ~ 3600.0s	---

Setting Output signal delay

- ◆ When set 03-16(P.120)=0 and condition from 03-11 (P.85) is met, signal will output directly.
- ◆ When set 03-16(P.120) = 0.1~3600 and condition from 03-11 (P.85) is met, signal will output after delay time.

5.4.5 Digital input signal filter

- This parameter is used to set response time for digital input signals.

Parameter	Name	Default	Setting Range	Content
03-17 P.157	Digital input terminal filter time	4	0 ~ 2000	---

Setting Digital input terminal filter

- ◆ 03-17 (P.157) is used to select the response time of the digital input terminal signal, the terminal includes: STR, STF, M0, M1. The actual delay time is 03-17(P.157)*2ms, for example, when 03-17(P.157)=100, the actual delay time is 200ms.

5.4.6 Digital input terminal enable when power on

- Choose when power on if digital input terminal operates immediately.

Parameter	Name	Default	Setting Range	Content
03-18 P.158	Digital input terminal enable when power on	0	0	When power on digital terminals work directly
			1	When power on digital terminals work after switch off then on

Setting Digital input terminal enable when power on

- ◆ If 03-18(P.158)=1, when terminal function STF, STR, RUN and MPO is already short before power on, after power on inverter will not run immediately, inverter will run only after switch off then on these terminals. If 03-18(P.158)=0, when terminal function STF, STR, RUN and MPO is already short before power on, after power on inverter will run immediately.

5.4.7 Output frequency detection

- Detects the inverter output frequency and output signal.

Parameter	Name	Default	Setting Range	Content
03-20 P.41	Output frequency detection sensitivity	10.0%	0 ~ 100.0%	---
03-21 P.42	Output frequency detection for forward rotation	6.00Hz	0 ~ 650.00Hz	---
03-22 P.43	Output frequency detection for reverse rotation	99999	0 ~ 650.00Hz	---
			99999	Same setting as 03-21(P.42).

Setting Output frequency detection range

- ◆ If 03-20(P.41)=5%, SU signal will be output when output frequency falls within “5% range around target frequency”. For example, the target frequency is set to 60Hz and 03-20(P.41)=5%, then when output frequency falls within the range of $60 \pm 60 \times 5\% = 57\text{Hz} \sim 63\text{Hz}$, SU signal will be output.

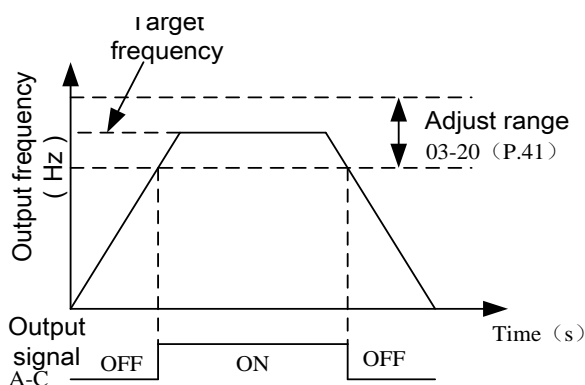

Setting Forward/Reverse rotation output frequency detection

- ◆ If 03-21(P.42)=30 and 03-22(P.43)=20, FU signal will output when forward rotation frequency exceeds 30Hz; and when reverse rotation frequency exceeds 20Hz, FU signal will also be output.
- ◆ If 03-21(P.42)=30 and 03-22(P.43)=99999 (default), FU signal will output when forward and reverse rotation frequency exceed 30Hz.

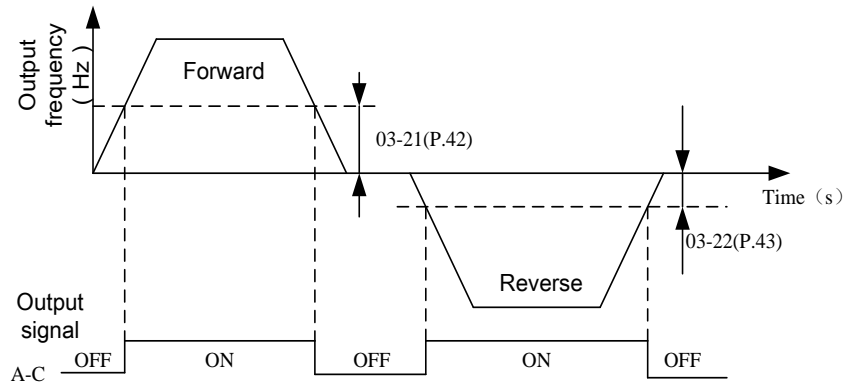

Note: SU and FU mentioned in this paragraph are the function names for A-C digital output. Please refer to 03-11(P.85) for details, and section 3.7 Terminal wire arrangement.

5.4.8 Zero current detection

- Detects output current level and send signal to digital output terminal.

Parameter	Name	Default	Setting Range	Content
03-23 P.62	Zero current detection level	5.0%	0 ~ 200.0%	---
			99999	Off
03-24 P.63	Zero current detection time	0.50s	0.05 ~ 100.00s	---
			99999	Off

Setting Zero current detection

- ◆ Assume inverter is fully loaded at rated value and current is 20A, set 03-23(P.62)=5% and 03-24(P.63)=0.5s, terminal function OMD will output signal when output current is less than $20 \times 5\% = 1A$ and exceeds 0.5s, as shown below figure:

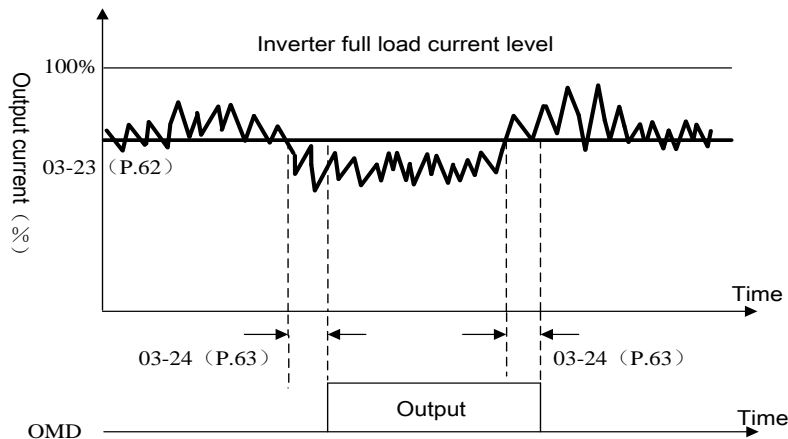

- ◆ If set 03-23(P.62) or 03-24(P.63) to 99999, zero current detection function is off.

Note: In this paragraph, OMD mentioned in this paragraph are the function names for digital output. Please refer to 03-11(P.85) for details, and section 3.7 Terminal wire arrangement.

5.5 Multi-speed parameter group 04

Group	Parameter Number	Name	Setting Range	Default	Page
04-00	P.4	Speed 1 (high speed)	0 ~ 650.00Hz	60.00Hz	100
04-01	P.5	Speed 2 (medium speed)	0 ~ 650.00Hz	30.00Hz	100
04-02	P.6	Speed 3 (low speed)	0 ~ 650.00Hz	10.00Hz	100
04-03	P.24	Speed 4	0 ~ 650.00Hz	99999	100
			99999: Off		
04-04	P.25	Speed 5	Same as 04-03	99999	100
04-05	P.26	Speed 6	Same as 04-03	99999	100
04-06	P.27	Speed 7	Same as 04-03	99999	100
04-07	P.142	Speed 8	Same as 04-03	0.00Hz	100
04-08	P.143	Speed 9	Same as 04-03	99999	100
04-09	P.144	Speed 10	Same as 04-03	99999	100
04-10	P.145	Speed 11	Same as 04-03	99999	100
04-11	P.146	Speed 12	Same as 04-03	99999	100
04-12	P.147	Speed 13	Same as 04-03	99999	100
04-13	P.148	Speed 14	Same as 04-03	99999	100
04-14	P.149	Speed 15	Same as 04-03	99999	100
04-15	P.100	Programmed operation minute / second selection	0: Select minute as the time increment.	1	102
			1: Select second as the time increment.		
04-16	P.121	Run direction in each section	0 ~ 255	0	102
04-17	P.122	Programmed operation cycle selection	0:Off	0	102
			1 ~ 8: Start cycle from the set section.		
04-18	P.123	Programmed operation acceleration / deceleration time setting selection	0: Acceleration time is 01-06(P.7), deceleration time is 01-07(P.8).	0	102
			1: Acceleration and deceleration time is set by 04-35(P.111) ~ 04-42(P.118).		
04-19	P.131	Programmed operation mode speed 1	0 ~ 650.00Hz	0.00 Hz	102
04-20	P.132	Programmed operation mode speed 2	0 ~ 650.00Hz	0.00 Hz	102
04-21	P.133	Programmed operation mode speed 3	0 ~ 650.00Hz	0.00 Hz	102
04-22	P.134	Programmed operation mode speed 4	0 ~ 650.00Hz	0.00 Hz	102
04-23	P.135	Programmed operation mode speed 5	0 ~ 650.00Hz	0.00 Hz	102
04-24	P.136	Programmed operation mode speed 6	0 ~ 650.00Hz	0.00 Hz	102
04-25	P.137	Programmed operation mode speed 7	0 ~ 650.00Hz	0.00 Hz	102
04-26	P.138	Programmed operation mode speed 8	0 ~ 650.00Hz	0.00 Hz	102

Group	Parameter Number	Name	Setting Range	Default	Page
04-27	P.101	Programmed operation mode speed 1 operating time	0 ~ 6000.0s	0.0s	102
04-28	P.102	Programmed operation mode speed 2 operating time	0 ~ 6000.0s	0.0s	102
04-29	P.103	Programmed operation mode speed 3 operating time	0 ~ 6000.0s	0.0s	102
04-30	P.104	Programmed operation mode speed 4 operating time	0 ~ 6000.0s	0.0s	102
04-31	P.105	Programmed operation mode speed 5 operating time	0 ~ 6000.0s	0.0s	102
04-32	P.106	Programmed operation mode speed 6 operating time	0 ~ 6000.0s	0.0s	102
04-33	P.107	Programmed operation mode speed 7 operating time	0 ~ 6000.0s	0.0s	103
04-34	P.108	Programmed operation mode speed 8 operating time	0 ~ 6000.0s	0.0s	103
04-35	P.111	Programmed operation mode speed 1 Acc/Dec time	0 ~ 600.00s/0 ~ 6000.0s	0.00s	103
04-36	P.112	Programmed operation mode speed 2 Acc/Dec time	0 ~ 600.00s/0 ~ 6000.0s	0.00s	103
04-37	P.113	Programmed operation mode speed 3 Acc/Dec time	0 ~ 600.00s/0 ~ 6000.0s	0.00s	103
04-38	P.114	Programmed operation mode speed 4 Acc/Dec time	0 ~ 600.00s/0 ~ 6000.0s	0.00s	103
04-39	P.115	Programmed operation mode speed 5 Acc/Dec time	0 ~ 600.00s/0 ~ 6000.0s	0.00s	103
04-40	P.116	Programmed operation mode speed 6 Acc/Dec time	0 ~ 600.00s/0 ~ 6000.0s	0.00s	103
04-41	P.117	Programmed operation mode speed 7 Acc/Dec time	0 ~ 600.00s/0 ~ 6000.0s	0.00s	103
04-42	P.118	Programmed operation mode speed 8 Acc/Dec time	0 ~ 600.00s/0 ~ 6000.0s	0.00s	103

5.5.1 16 steps speed

- With the combination of digital input terminal RL, RM, RH and REX, 16 steps speed can be selected (up to 16 speeds)

Parameter	Name	Default	Setting Range	Content
04-00 P.4	Speed 1 (high speed)	60.00Hz	0 ~ 650.00Hz	---
04-01 P.5	Speed 2 (medium speed)	30.00Hz	0 ~ 650.00Hz	---
04-02 P.6	Speed 3 (low speed)	10.00Hz	0 ~ 650.00Hz	---
04-03 P.24	Speed 4	99999	0 ~ 650.00Hz	---
			99999	99999: Off
04-04 P.25	Speed 5	99999	Same as 04-03	Same as 04-03
04-05 P.26	Speed 6	99999	Same as 04-03	Same as 04-03
04-06 P.27	Speed 7	99999	Same as 04-03	Same as 04-03
04-07 P.142	Speed 8	0.00Hz	Same as 04-03	Same as 04-03
04-08 P.143	Speed 9	99999	Same as 04-03	Same as 04-03
04-09 P.144	Speed 10	99999	Same as 04-03	Same as 04-03
04-10 P.145	Speed 11	99999	Same as 04-03	Same as 04-03
04-11 P.146	Speed 12	99999	Same as 04-03	Same as 04-03
04-12 P.147	Speed 13	99999	Same as 04-03	Same as 04-03
04-13 P.148	Speed 14	99999	Same as 04-03	Same as 04-03
04-14 P.149	Speed 15	99999	Same as 04-03	Same as 04-03

Setting

16 steps speed

- ◆ If all the values of 04-03~04-06(P.24~P.27), 04-08~04-14(P.143~P.149) are not 99999, "16 steps speed" is active. It means with the combination of RL, RM, RH and REX, there are 16 speeds in total. To set target frequency for inverter, please refer to the figure below:

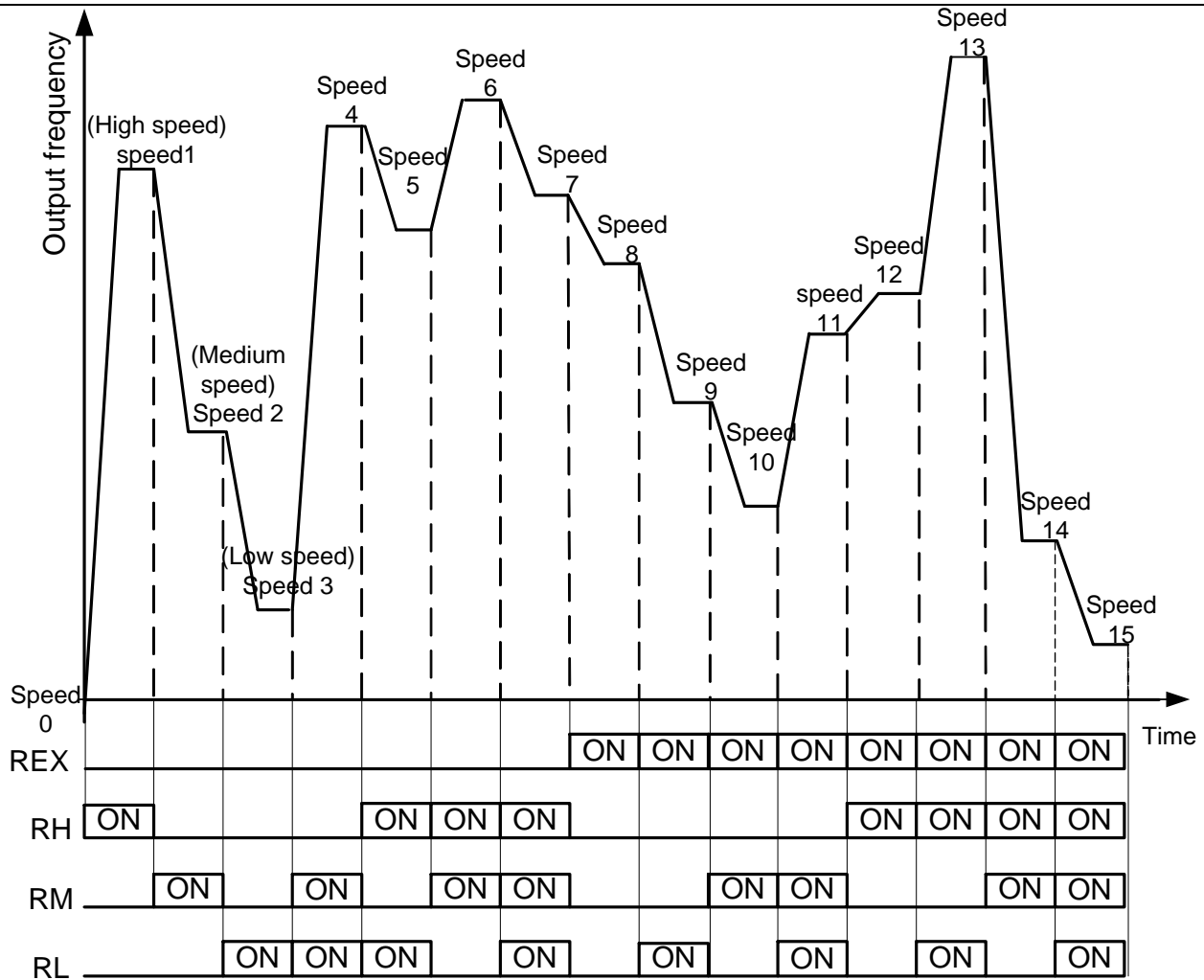

- ◆ When one of parameters 04-03~04-06(P.24~P.27), 04-08~04-14(P.143~P.149) value is 99999, the target frequency is determined by the speed of RL, RM and RH, which is shown as below (the priority of terminals is $RL > RM > RH$):

Parameter Target frequency	04-03 (P.24) =99999	04-04 (P.25) =99999	04-05 (P.26) =99999	04-06 (P.27) =99999	04-07 (P.142) =99999	04-08 (P.143) =99999	04-09 (P.144) =99999	04-10 (P.145) =99999	04-11 (P.146) =99999	04-12 (P.147) =99999	04-13 (P.148) =99999	04-14 (P.149) =99999
RL (04-02)	○	○		○	○	○		○		○		○
RM (04-01)			○				○				○	
RH (04-00)									○			

For example, when 04-05(P.26) = 99999, the target frequency is determined by RM(the setting value of 04-01(P.5)).

Note: 1. Multi-speed is only valid in “external mode”, “combination mode 2” or “combined mode 4”.

2. RL, RM, RH and REX mentioned in this section are the function names of the “multi-function digital input terminal”. (For example, when 03-03(P.80)=2, select the M0 terminal to perform the RL function) Please refer to 03-00(P.83), 03-01(P.84), 03-03(P.80), 03-04(P.81) for function selection and purposes of the multi-function digital input terminal. For related wiring, please refer to Section 3.7 Terminal wire arrangement.

5.5.2 Programmed operation mode

- The application of this parameter can be used as the operation process control for general small machinery, food processing machinery and washing equipment, which can replace some traditional relays, switches, timer and other control circuit, etc.

Parameter	Name	Default	Setting Range	Content
04-15 P.100	Programmed operation minute / second selection	1	0	Select minute as the time increment.
			1	Select second as the time increment.
04-16 P.121	Run direction in each section	0	0 ~ 255	---
04-17 P.122	Programmed operation cycle selection	0	0	Off
			1 ~ 8	Start cycle from the set section.
04-18 P.123	Programmed operation acceleration / deceleration time setting selection	0	0	Acceleration time is 01-06(P.7), deceleration time is 01-07(P.8).
			1	Acceleration and deceleration time is set by 04-35(P.111) ~ 04-42(P.118).
04-19 P.131	Programmed operation mode speed 1	0.00Hz	0 ~ 650.00Hz	---
04-20 P.132	Programmed operation mode speed 2	0.00Hz	0 ~ 650.00Hz	---
04-21 P.133	Programmed operation mode speed 3	0.00Hz	0 ~ 650.00Hz	---
04-22 P.134	Programmed operation mode speed 4	0.00Hz	0 ~ 650.00Hz	---
04-23 P.135	Programmed operation mode speed 5	0.00Hz	0 ~ 650.00Hz	---
04-24 P.136	Programmed operation mode speed 6	0.00Hz	0 ~ 650.00Hz	---
04-25 P.137	Programmed operation mode speed 7	0.00Hz	0 ~ 650.00Hz	---
04-26 P.138	Programmed operation mode speed 8	0.00Hz	0 ~ 650.00Hz	---
04-27 P.101	Programmed operation mode speed 1 operating time	0.0s	0 ~ 6000.0s	---
04-28 P.102	Programmed operation mode speed 2 operating time	0.0s	0 ~ 6000.0s	---
04-29 P.103	Programmed operation mode speed 3 operating time	0.0s	0 ~ 6000.0s	---
04-30 P.104	Programmed operation mode speed 4 operating time	0.0s	0 ~ 6000.0s	---
04-31 P.105	Programmed operation mode speed 5 operating time	0.0s	0 ~ 6000.0s	---
04-32 P.106	Programmed operation mode speed 6 operating time	0.0s	0 ~ 6000.0s	---

Parameter	Name	Default	Setting Range	Content
04-33 P.107	Programmed operation mode speed 7 operating time	0.0s	0 ~ 6000.0s	---
04-34 P.108	Programmed operation mode speed 8 operating time	0.0s	0 ~ 6000.0s	---
04-35 P.111	Programmed operation mode speed 1 Acc/Dec time	0.00s	0 ~ 600.00s/ 0 ~ 6000.0s	---
04-36 P.112	Programmed operation mode speed 2 Acc/Dec time	0.00s	0 ~ 600.00s/ 0 ~ 6000.0s	---
04-37 P.113	Programmed operation mode speed 3 Acc/Dec time	0.00s	0 ~ 600.00s/ 0 ~ 6000.0s	---
04-38 P.114	Programmed operation mode speed 4 Acc/Dec time	0.00s	0 ~ 600.00s/ 0 ~ 6000.0s	---
04-39 P.115	Programmed operation mode speed 5 Acc/Dec time	0.00s	0 ~ 600.00s/ 0 ~ 6000.0s	---
04-40 P.116	Programmed operation mode speed 6 Acc/Dec time	0.00s	0 ~ 600.00s/ 0 ~ 6000.0s	---
04-41 P.117	Programmed operation mode speed 7 Acc/Dec time	0.00s	0 ~ 600.00s/ 0 ~ 6000.0s	---
04-42 P.118	Programmed operation mode speed 8 Acc/Dec time	0.00s	0 ~ 600.00s/ 0 ~ 6000.0s	---

Setting Programmed operation mode

◆ Programmed operation mode

- The calculation method of running time and acceleration/deceleration time for each speed is shown in the following figure:

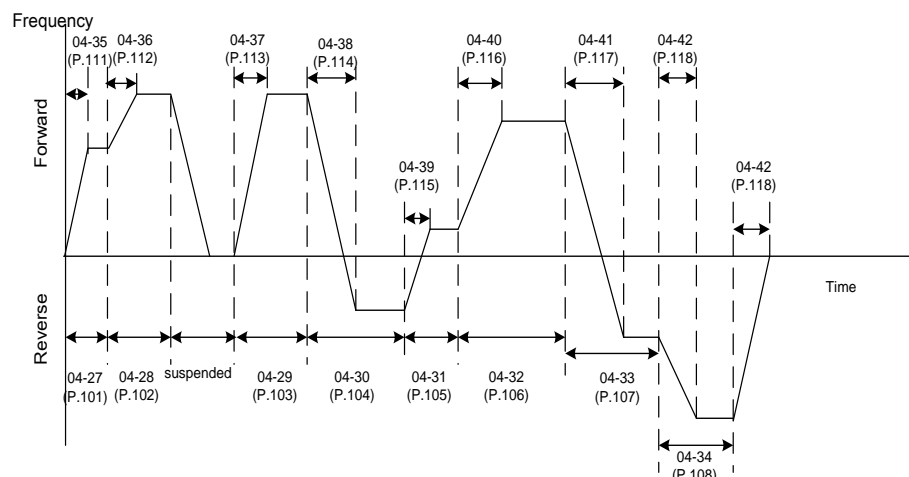

- Setting method of operation direction: set in binary (8 bit), then convert into decimal and set in parameter 04-16(P.121) Wherein, 1 means forward rotation, 0 means reverse rotation, the highest bit is the direction of speed 8, and the lowest bit is the direction of speed 1.

For example: if speed 1 is forward, speed 2 is reverse, speed 3 is reverse, speed 4 is forward, speed 5 is reverse, speed 6 is forward, speed 7 is forward, and speed 8 is reverse, then the binary number is 01101001.

$$04-16(P.121) = 0 \times 2^7 + 1 \times 2^6 + 1 \times 2^5 + 0 \times 2^4 + 1 \times 2^3 + 0 \times 2^2 + 0 \times 2^1 + 1 \times 2^0 = 105$$

3. When 04-16(P.121) is set to 0, there will be no cycle operation.
4. When 04-17(P.122) is 1~8, it is the section that will cycle to after the first cycle.
For example: When 04-17(P.122)=3, the cycle operation will start from speed 3 after the speed 1 to speed 8 operations have been completed.
5. When 04-18(P.123) is set to 0, the acceleration time is 01-06 (P.7) and the deceleration time is 01-07(P.8).
6. When 04-18(P.123) is set to 1, the acceleration time and deceleration time are both determined by 04-35~04-42 (P.111~P.118). If any value in 04-35 (P.111) ~ 04-42 (P.118) is set to 0, the acceleration time will still be 01-06 (P.7), 01-07 (P.8).

◆ Manual cycle mode

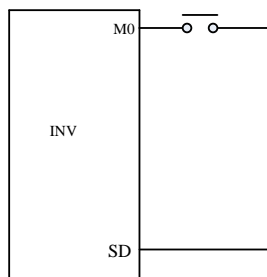

Wiring diagram for manual cycle mode

1. Connect a push button between M0 and SD.
2. After powered on, set the correspond parameter 03-03(P.80) to 35 according to the terminal. At this time, the inverter is in standby state.
3. Operation is shown in the figure below:

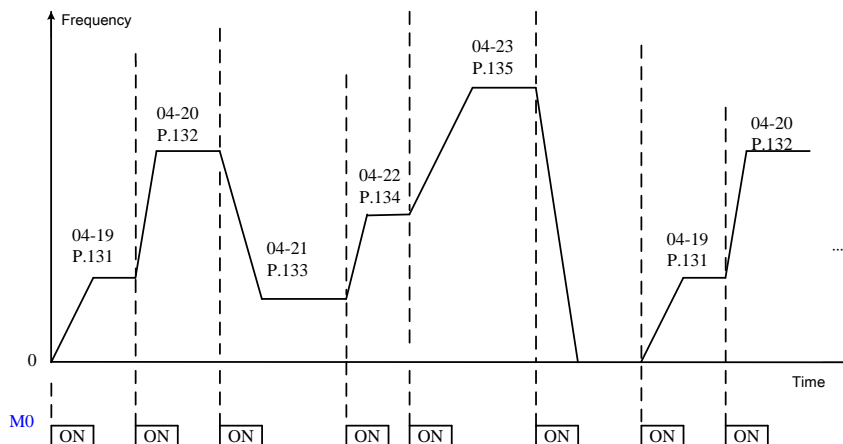

Note:1. This program can run 8 speeds at most, which can be set by 04-19~04-26(P.131~P.138).

2. Settings for parameters 04-15~04-18(P.100、 P.121~P.123)、 04-27~04-42(P.101~P.118) are only for the programmed operation mode not manual cycle mode. For the acceleration and deceleration time of manual cycle mode, please refer to 01-06(P.7), 01-07(P.8), 01-22(P.44), 01-23(P.45).
3. If any segment is set to zero, inverter will return to standby state when run to this segment. This means that when this mode is selected, 04-19(P.131) cannot be 0. As shown in the above diagram, if 04-24(P.136) is 0, regardless of the values of 04-25(P.137) and 04-26(P.138), inverter will stop running when the switch is pressed for the sixth time.
4. Manual cycle function rotation direction is single direction, which has nothing to do with the operation direction parameter 04-16(P.121) of each speed in the programmed operation mode, and has nothing to do with STF and STR signals.
5. For 04-35~04-42(P.111~P.118) please refer to acceleration and deceleration time increments parameter 01-08(P.21).

5.6 Motor parameter group 05

Group	Parameter Number	Name	Setting Range	Default	Page
05-00	P.301	Motor specifications automatic measurement	0: Off	0	105
			1: Induction motor specifications automatic measurement (Run motor to measure)		
			2: Induction motor specifications automatic measurement (Don't run motor to measure)		
			3: Induction motor specifications automatic measurement (Measure when operating)		
05-01	P.302	Motor rated power	0 ~ 160.00kW	0.00kW	107
05-02	P.303	Motor poles	0 ~ 256	4	107
05-03	P.304	Motor rated voltage	0 ~ 510V	380V/ 440V	107
				220V	
05-04	P.305	Motor rated frequency	50Hz system : 0 ~ 650.00Hz	50.00Hz	107
			60Hz system : 0 ~ 650.00Hz	60.00Hz	
05-05	P.306	Motor rated current	0~500.0A	According to kw	107
05-06	P.307	Motor rated rotation speed	50Hz system : 0 ~ 65000r/min	1410r/min	107
			60Hz system : 0 ~ 65000r/min	1710r/min	
05-07	P.308	IM Motor excitation current	0~500.00A	According to kw	107
05-08	P.309	IM motor stator resistance	0 ~ 99.98Ω :	According to kw	107

5.6.1 Motor parameter automatic measurement

- By accurate motor parameter measuring function, realize motor high-performance vector control.

Parameter	Name	Default	Setting Range	Content
05-00 P.301	Motor specifications automatic measurement	0	0	Off
			1	Induction motor specifications automatic measurement (Run motor to measure)
			2	Induction motor specifications automatic measurement (Don't run motor to measure)
			3	Induction motor specifications automatic measurement (Measure when operating)

Setting Motor parameter automatic measurement

- ◆ If 00-21(P.300)=0, inverter operate normally according to V/F curve without automatic measuring motor parameters.
- ◆ When controlling induction motor by general flux vector control, please set 00-21(P.300) as 2. Voltage will increase to compensate for the frequency change when the motor load increases.
- ◆ To do induction motor parameter automatic measurement function, in PU mode set 05-00(P.301) as 1 or 2, and press forward or reverse rotation key. During measurement, keypad will flash and display "TUN". If measurement fails, keypad will flash "FAL" for three seconds.

◆ Automatic induction motor parameters measurement includes the following steps:

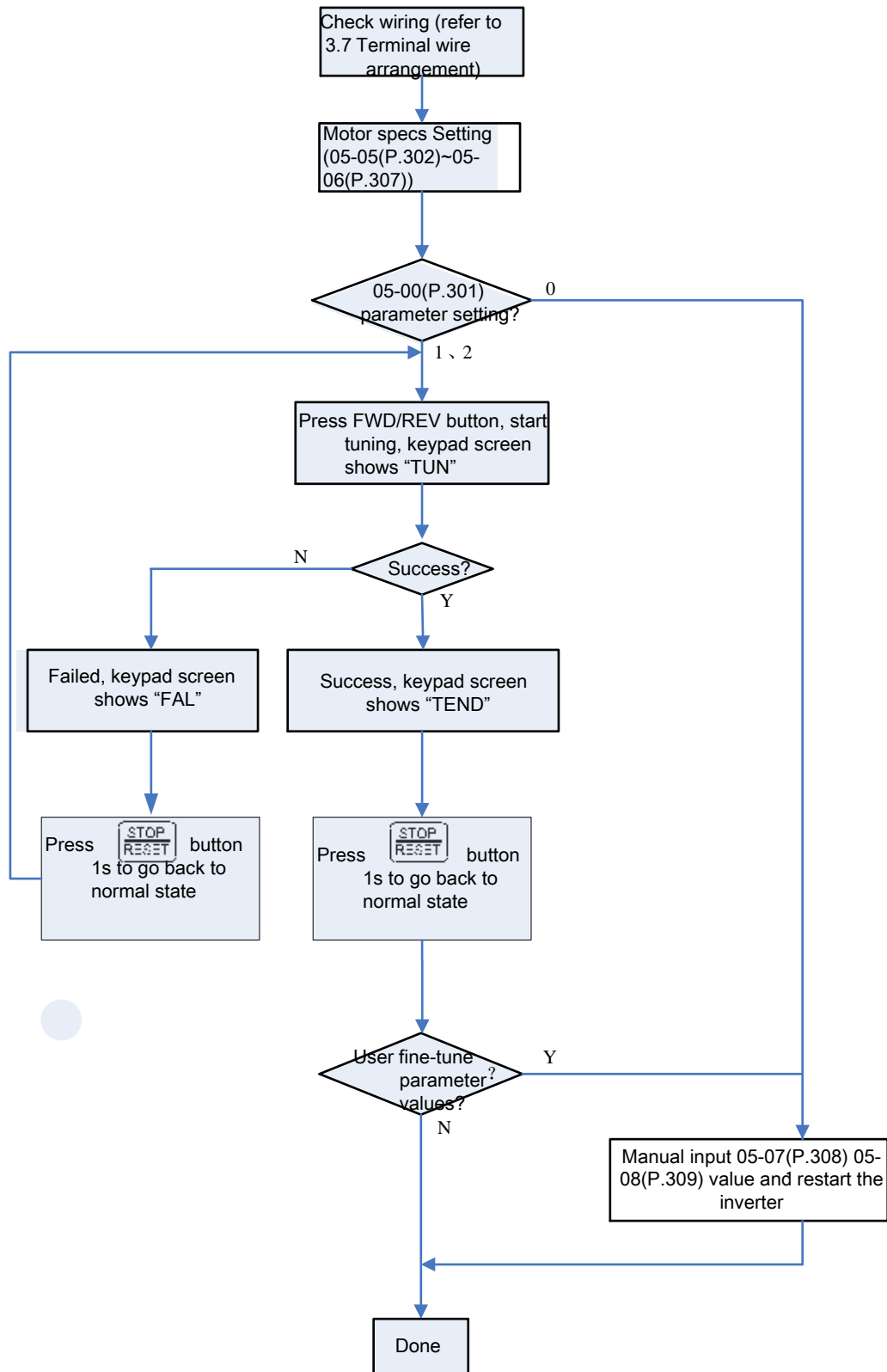

Note: 1. Motor capacity must be the same level or one level lower than inverter capacity.

2. When the automatic measurement function is used, if motor can rotate, please set 05-00(P.301)=1 (dynamic measurement). The load must be completely separated from motor. During Auto-tuning if the motor cannot rotate due to environment, please set 05-00 (P.301) = 2 (static measurement).

3. Induction motor sensorless vector control: automatic measurement function can be used to enhance the control function. Before setting 05-00(P.301)=1~3 set the motor parameters first and then do automatic measurement function to improve the control accuracy.

5.6.2 Motor parameter

- Inverter has built-in standard parameters for motor. Modify the default values according to the actual situation to conform to the actual values as much as possible.

Parameter	Name	Default	Setting Range	Content
05-01 P.302	Motor rated power	0.00kW	0 ~ 160.00kW	---
05-02 P.303	Motor poles	4	0 ~ 256	---
05-03 P.304	Motor rated voltage	380V/440V	0 ~ 510V	440V 50Hz/60Hz system
		220V		220V system
05-04 P.305	Motor rated frequency	50.00Hz	0 ~ 650.00Hz	50Hz system (when 00-24(P.189)=1)
		60.00Hz		60Hz system (when 00-24(P.189)=0)
05-05 P.306	Motor rated current	According to kw	0 ~ 500.00A	
05-06 P.307	Motor rated rotation speed	1410r/min	0 ~ 65000r/min	50Hz system (when 00-24(P.189)=1)
		1710r/min		60Hz system (when 00-24(P.189)=0)
05-07 P.308	IM Motor excitation current	According to kw	0 ~ 500.00A	
05-08 P.309	IM motor stator resistance	According to kw	0 ~ 99.98Ω	

Setting Motor parameter

- ◆ If induction motor can be completely disconnected from the load, select 05-00(P.301)=1 run motor to measure, then press or on keypad and inverter will automatically calculate following parameters:
05-07(P.308)~05-08(P.309)
- ◆ If induction motor cannot be completely separated from the load, select 05-00(P.301)=2 don't run motor to measure, then press or on keypad and inverter will automatically calculate following parameters:05-07(P.308)~05-08(P.309)
- ◆ Users can also calculate these two parameters according to motor nameplate, parameters motor nameplate used are: rated voltage U , rated current I , rated frequency f and power factor η .
- ◆ Calculation method of no-load excitation current and mutual inductance of the motor is as follows, where L_δ is leakage inductance of the motor.
- ◆ Idling current: $I_0 = I \times \sqrt{1 - \eta^2}$, Mutual inductance calculation: $L_m = \frac{U}{2\sqrt{3} \cdot \pi \cdot f \cdot I_0} - L_\delta$, I_0 is the idling current, L_m is mutual inductance, L_δ is leakage inductance.

Note: 1. When inverter is used with different size motor, please be sure to set parameters 05-01(P.302)~05-06(P.307)。 Vector control relies heavily on motor parameters, so to obtain good control performance, accurate parameters of the motor controlled must be set.

2. If one or more parameter values in 05-01(P.302)~05-08(P.309) have been manually modified, reset the inverter to reload the new parameter values.

5.7 Protection parameter group 06

Group	Parameter Number	Name	Setting Range	Default	Page
06-00	P.9	Electronic thermal relay capacity	0~500.00A	0.00A	110
06-01	P.22	Stall prevention operation level	0 ~ 250.0%	150.0%	111
06-02	P.23	Stall prevention operation level correction factor	0 ~ 200.0%	99999	111
			99999: Stall prevention operation level is the setting value of 06-01(P.22).		
06-03	P.66	Stall prevention operation reduction starting frequency	50Hz system:0 ~ 650.00Hz	50.00Hz	111
			60Hz system:0 ~ 650.00Hz	60.00Hz	
06-05	P.30	Regenerative brake selection	0: Brake duty is fixed at 3%, parameter 06-06(P.70) will be off.	0	112
			1: Brake duty is 06-06(P.70) value.		
06-06	P.70	Special regenerative brake duty	0 ~ 100.0%	0.0%	112
06-08	P.155	Over torque detection level	0 ~ 200.0%	0.0%	113
06-09	P.156	Over torque detection time	0 ~ 60.0s	1.0s	113
06-10	P.260	Action when detect over torque	0: OL2 alarm will not be reported after over torque detection, and inverter keeps running.	1	113
			1: OL2 alarm will be reported after over torque detection, and inverter stops.		
06-12	P.245	Cooling fan working mode	0 :When running turn on the fan, after stop for 30 seconds turn off the fan.	1	114
			1 : When power on turn on the fan, after power off turn off the fan.		
			2 : When running and the heat sink temperature exceeds 60°C turn on the fan, under 40°C turn off the fan.		
			3 : When the heat sink temperature exceeds 60°C turn on the fan, under 40°C turn off the fan.		
06-13	P.281	Input phase loss protection	0: Off	0	114
			1: When input phase loss, built-in keypad shows IPF alarm and inverter stops		
06-17	P.261	Maintenance alarm function	0: Off	0	114
			1 ~ 9998day: Used to set the time for maintenance alarm output signal		
06-18	P.280	Detection for leakage current of ground when starting	XX0 : Off	0	114
			XX1 : Detect leakage current of ground when inverter starts		
			0X1 : Detect leakage current of ground only for the first startup		
			1X1 : Detect leakage current of ground for every startup.		
06-19	P.282	GF detection level when operating	0 ~ 100%	50%	114

Group	Parameter Number	Name	Setting Range	Default	Page
06-27	P.292	Total inverter operation time (minutes)	0 ~ 1439 min	0min	115
06-28	P.293	Total inverter operation time (days)	0 ~ 9999 day	0day	115
06-29	P.296	Total inverter power on time (minutes)	0 ~ 1439 min	0min	115
06-30	P.297	Total inverter power on time (days)	0 ~ 9999 day	0day	115
06-40	P.288	Alarm record code query	Choose 0 ~ 12 recorded alarm	0	116
06-41	P.289	Alarm record code display	Read only	Read only	116
06-42	P.290	Alarm record message query	Choose 0 ~ 10 recorded alarm	0	116
06-43	P.291	Alarm record message display	Read only	Read only	116
06-84	P.207	Fire mode	XXX0:Invalid(the fire mode is forbidden(normal mode))	0	117
			XXX1:Forward operation(the inverter runs forward in fire mode)		
			XXX2:Reverse operation(the inverter runs reversely in fire mode)		
			0XXX:Manually exit fire mode 1 (if the start fire mode terminal is OFF, the inverter need reset manually and back to normal mode)		
			1XXX:Exit fire mode automatically (if the start fire mode terminal is OFF, the inverter goes to normal mode automatically)		
			2XXX Manually exit fire mode 2(if the start fire mode terminal is OFF, the inverter keeps running, need reset manually and back to normal mode)		
06-85	P.208	Frequency setting in fire mode	0~650.00Hz	60.00Hz	117
06-88	P.209	Accumulated times in fire mode	Read only	Read only	117

5.7.1 Electronic thermal relay capacity

- “Electronic thermal relay” uses inverter computing power to simulate a thermal relay for preventing motor from overheating.

Parameter	Name	Default	Setting Range	Content
06-00 P.9	Electronic thermal relay capacity	0.00A	0~500.00A	---

Setting

 Electronic thermal relay capacity

- ◆ Please set the value of 06-00(P.9) as the rated current value of the motor at the rated frequency. Rated frequencies of squirrel cage induction motors manufactured in different countries and regions are different. Please refer to the motor nameplate for specific data.
- ◆ If 06-00(P.9)=0, electronic thermal relay is off.
- ◆ When the electronic thermal relay calculates that the motor has accumulated too much heat, the keypad will display an alarm code **F H N** and the output will stop.

Note: 1. After the inverter is reset, the heat accumulation record of the electronic thermal relay will return to zero, this should be paid attention to during use.

2. If two or more motors are connected to the inverter, the electronic thermal relay cannot be used as overheat protection for the motors. Please install external thermal relay on each motor.

3. When special motors are used, electronic thermal relay cannot be used for protection. Please install external thermal relay on the motor.

4. Please refer to 03-00(P.83)~03-01(P.84) , 03-03(P.80)~03-04(P.81) for the use and wiring method of thermal relay.

5.7.2 Current stalling protection

- In order to avoid the alarm and stop of the inverter due to overcurrent and overvoltage, the output current is monitored to automatically change the output frequency. It can realize stall prevention during acceleration and deceleration process or during electric regeneration, and make high response current limit valid.

Parameter	Name	Default	Setting Range	Content
06-01 P.22	Electronic thermal relay capacity	150.0%	0 ~ 250.0%	---
06-02 P.23	Stall prevention operation level	99999	0 ~ 200.0%	---
			99999	Stall prevention operation level is the setting value of 06-01(P.22).
06-03 P.66	Stall prevention operation level correction factor	50.00Hz	0 ~ 650.00Hz	50Hz system (when 00-24(P.189)=1)
		60.00Hz		60Hz system (when 00-24(P.189)=0)

Setting Current stalling protection

- ◆ When Heavy Duty and motor starts or target frequency changes (increases), the rotating speed of motor often cannot keep up with the speed of output frequency change. When the rotation speed of motor is lower than output frequency, output current will increase to enhance output torque. However, if the difference between output frequency and motor speed is too large, motor torque will be reduced, which is called “stall”.

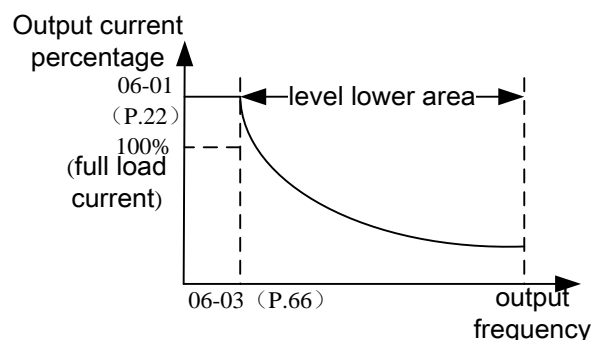

Formula for stall prevention level:

$$\text{Level percentage} = A + B \times \frac{06-01(P.22) - A}{06-01(P.22) - B} \times \frac{06-02(P.23) - 100}{100}$$

$$A = \frac{(06-23(P.66)) \times (06-01(P.22))}{\text{Output frequency}} \quad B = \frac{(06-23(P.66)) \times (06-01(P.22))}{400}$$

5.7.3 Regenerative brake

- When performing frequent start and stop operation, regenerative brake usage rate can be increased by using the brake resistor or the brake unit.

Parameter	Name	Default	Setting Range	Content
06-05 P.30	Regenerative brake selection	0	0	Brake duty is fixed at 3%, parameter 06-06(P.70) will be off.
			1	Brake duty is 06-06(P.70) value.
06-06 P.70	Special regenerative brake duty	0.0%	0 ~ 100.0%	---

Setting

Regenerative brake

- ◆ During the period when output frequency of inverter changes from high frequency to low frequency, due to load inertia, the rotating speed of the motor is higher than the output frequency of inverter at an instant, thus forming the generator effect. This will cause regenerative voltage between main circuit terminals, which may result in damage to inverter. Therefore, a regenerative braking resistor with an appropriate size is installed between main circuit terminals +/P and PR to absorb the feedback energy.
- ◆ There is a transistor in inverter and the proportion of conduction time is called “regenerative braking duty”. The greater the value of regenerative braking duty, the more energy regenerative braking resistor consumes and the stronger the braking capability.

Note: 1. If inverter is used in high-frequency start/stop case, it need a high-power regenerative braking resistor.

2. Please refer to section 3.6.3 for choosing regenerative braking resistor.

5.7.4 Over torque detection

➤ Output current detection function can be used for over torque detection.

Parameter	Name	Default	Setting Range	Content
06-08 P.155	Over torque detection level	0.0%	0	No over torque detection.
			0.1~200%	Over torque detection.
06-09 P.156	Over torque detection time	1.0s	0 ~ 60.0s	---
06-10 P.260	Action when detect over torque	1	0	OL2 alarm will not be reported after over torque detection, and inverter keeps running.
			1	OL2 alarm will be reported after over torque detection, and inverter stops.

Setting Over torque detection

- ◆ If set value of 06-08(P.155) is not zero, over-torque detection function is on.
- ◆ If output current exceeds over-torque detection level (06-08(P.155)) and over-torque detection time (06-09(P.156)), inverter will trigger OL2 alarm and stop. If relay output terminals A-C(03-11(P.85)) is set to over-torque alarm (set value is 12), inverter will output a signal. If relay output terminals A-C (03-11(P.85)) is set to over-load alarm (set value is 3), and 06-10 (P.260) =1, inverter will output a signal. Please refer to Chapter 5.4.2 Digital output terminals function selection for details.

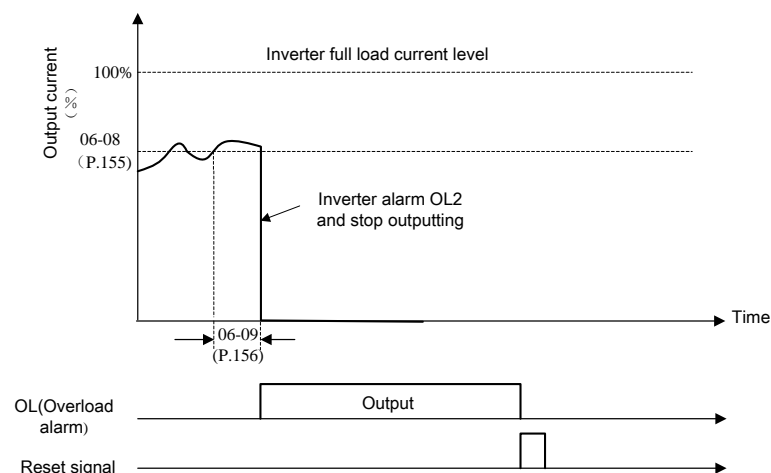

5.7.5 Cooling fan working mode

- Control the start and stop conditions of the fan and the alarm output mode through parameter settings.

Parameter	Name	Default	Setting Range	Content
06-12 P.245	Cooling fan working mode	1	0	When running turn on the fan, after stop for 30 seconds turn off the fan.
			1	When power on turn on the fan, after power off turn off the fan.
			2	When running and the heat sink temperature exceeds 60°C turn on the fan, under 40°C turn off the fan.
			3	When the heat sink temperature exceeds 60°C turn on the fan, under 40°C turn off the fan.

Note: According to the environmental conditions of the inverter installation, if the fan can be set reasonably to run as little as possible, the life of the fan can be extended.

5.7.6 Maintenance alarm function

- Inverter counts operation time and trigger maintenance alarm output signal after time set.

Parameter	Name	Default	Setting Range	Content
06-17 P.261	Maintenance alarm function	0	0	Off
			1 ~ 9998day	Used to set the time for maintenance alarm output signal

Setting

Maintenance alarm function

- ◆ When the multi-function digital output terminal function selection (03-11 (P.85)) is equal to 18, it is the maintenance alarm function. That is, when the number of operating days of the inverter reaches the setting value of the maintenance alarm function 06-17 (P.261) value, the inverter multi-function relay will output a signal.

5.7.7 Short circuit to ground protection

- Use parameters to control whether to enable ground leakage current detection, and set the detection level.

Parameter	Name	Default	Setting Range	Content
06-18 P.280	Short circuit to ground protection function when start	0	XX0	Off
			XX1	Detect leakage current of ground when inverter starts
			0X1	Detect leakage current of ground only for the first startup
			1X1	Detect leakage current of ground for every startup
06-19 P.282	GF detection level when operating	50%	0 ~ 100%	---

Setting

Short circuit to ground protection

- ◆ The short circuit to ground detection when start is only implemented after the start signal is input to the inverter.
- ◆ 06-18 (P.280) is used to set short circuit to ground protection function when start or not, the ground leakage current detection during operation is set by 06-19 (P.282)
- ◆ If short circuit to ground detection when start is selected, and the output short-circuit current to ground is detected, and the percentage of the short-circuit current corresponding to the rated current exceeds 06-19 (P.282), the inverter stops output and alarm GF.

5.7.8 Input phase loss protection

- Turn on input phase failure protection

Parameter	Name	Default	Setting Range	Content
06-13 P.281	Input phase loss protection	0	0	Off
			1	When input phase loss, built-in keypad shows IPF alarm and inverter stops

Setting Input phase loss protection

- ◆ When 06-13(P.281)=1, input phase loss protection is on; when input power is out of phase inverter will trigger alarm IPF.

5.7.9 Time record function

- It is used to record the inverter accumulative operation time.

Parameter	Name	Default	Setting Range	Content
06-27 P.292	Total inverter operation time (minutes)	0 min	0 ~ 1439 min	---
06-28 P.293	Total inverter operation time (days)	0 day	0 ~ 9999 day	---
06-29 P.296	Total inverter power on time (minutes)	0 min	0 ~ 1439 min	---
06-30 P.297	Total inverter power on time (days)	0 day	0 ~ 9999 day	---

Setting Time record function

- ◆ 06-27(P.292)/06-29(P.296) is operation minutes of the inverter. The value cannot be changed when 00-02=3 (P.998=1) is executed or power is cut off, but can be cleared when set 06-27(P.292)/06-29(P.296) to 0.
- ◆ 06-28(P.293)/06-30(P.297) is operation days of the inverter. The value cannot be changed when 00-02=3 (P.998=1) is executed or power is cut off, but can be cleared when set 06-28(P.293)/06-30(P.297) to 0.

5.7.10 Alarm query function

➤ This function provides users with information about latest 12 alarm codes.

Parameter	Name	Default	Setting Range	Content	
06-40 P.288	Alarm record code query	0	0 ~ 12	06-40 (P.288) value 1~12 corresponds to 06-41(P.289)'s alarm E1~E12.	
06-41 P.289	Alarm record code display	Read only	Read only		
06-42 P.290	Alarm record message query	0	0 ~ 12	Alarm of current and prior alarm	06-42 (P.290) =1 , 06-43 (P.291) displays current frequency of present alarm 06-42 (P.290) =2 , 06-43 (P.291) displays current current of present alarm. 06-42 (P.290) =3 , 06-43 (P.291) displays current voltage of present alarm 06-42 (P.290) =4 , 06-43 (P.291) displays current temperature rising accumulation rate of present alarm 06-42 (P.290) =5 , 06-43 (P.291) displays current DC bus voltage of present alarm 06-42 (P.290) =6 , 06-43 (P.291) displays current inverter operation time of present alarm 06-42 (P.290) =7 , 06-43 (P.291) displays frequency of previous alarm 06-42 (P.290) =8 , 06-43 (P.291) displays current of previous alarm 06-42 (P.290) =9 , 06-43 (P.291) displays voltage of previous alarm 06-42 (P.290) =10 , 06-43 (P.291) displays temperature rising accumulation rate of previous alarm 06-42 (P.290) =11 , 06-43 (P.291) displays DC bus voltage of previous alarm 06-42 (P.290) =12 , 06-43 (P.291) displays inverter operation time of previous alarm
06-43 P.291	Alarm record message query	Read only	Read only		

Setting

Alarm query function

- ◆ User can read this parameter to know previous 12 alarms and the latest two with corresponding information such as frequency, current and voltage. Alarm number recorded by this parameter and status information when alarm occurs will be cleared if perform 00-02=1(P.996=1) operation.
- ◆ If parameters 06-40(P.288) and 06-42(P.290) are both 0, 06-41(P.289) and 06-43(P.291) will also display 0.
- ◆ Alarm number corresponded alarm code :

Alarm number	Alarm code	Alarm number	Alarm code	Alarm number	Alarm code	Alarm number	Alarm code	Alarm number	Alarm code
00	No alarm	32	OV1	49	THN	97	OLS	160	OPT
16	OC1	33	OV2	50	NTC	98	OL2	192	CPU
17	OC2	34	OV3	64	EEP	128	GF	193	CPR
18	OC3	35	OV0	82	IPF	129	AErr		
19	OC0	48	THT	83	PIDE	144	OHT		

5.7.11 Fire mode

➤ Fire mode applies to the field of fire control

Parameter	Name	Default Value	Setting Range	Content
06-84 P.207	Fire Mode	0	XXX0	Invalid : Fire mode is forbidden(normal mode)
			XXX1	Forward operation : The inverter runs forward in fire mode
			XXX2	Reverse operation : The inverter runs reversely in fire mode
			0XXX	Manually exit fire mode 1 : If the start fire mode terminal is OFF, the inverter need reset manually and back to normal mode
			1XXX	Exit fire mode automatically : If the start fire mode terminal is OFF, the inverter goes to normal mode automatically
			2XXX	Manually exit fire mode 2 : If the start fire mode terminal is OFF, the inverter keeps running, need reset manually and back to normal mode
06-85 P.208	Frequency setting in fire mode	60.00Hz	0~650.00Hz	Fire mode target frequency
06-88 P.209	Accumulated times in fire mode	0	Read only	Number of times in fire mode

Setting Fire mode

◆ Start fire mode

When 06-84 (P.207) =XXX1 or XXX2 and multi-function terminal=92 is ON, the inverter goes into fire mode: the inverter frequency accelerates to 06-85(P.208)set up value, fire warning shows on the keypad panel, and the inverter mode is in fire mode. The accumulated times of inverter in fire mode records in 06-88 (P.209). If multi-function output terminal=42, the inverter provides the fire mode operating command output.

◆ An alarm happens in fire mode

When in fire mode, if an alarm happens, the inverter starts to reset after wait for 10-14(P.68) seconds. There is no upper limit times to reset the inverter. Any alarm happens, the inverter stops immediately and motor runs in idle speed. When reset starts, if over-current alarm happens, the inverter can use parameter 10-08(P.150)= 32 to avoid.

◆ Exit fire mode

When input terminal=92/93 , the terminal is ON and then OFF

- 1.06-84(P.207)= 0XXX means manually exit fire mode 1 : stop the inverter, power OFF, and then power ON/reset the inverter to exit.
- 2.06-84(P.207)= 1XXX means exit fire mode automatically: the inverter stops and return to normal mode automatically.
3. 06-84(P.207)= 2XXX means manually exit fire mode 2: the inverter keeps running, power OFF and then power ON/reset to exit.

Note :

- 1.When in fire mode, the running direction of the inverter is base on 06-84(P.207)=XXX1(forward)orXXX2(reverse). The other running direction are all disabled. Parameter 00-15 (P.78) forward &reverse running are disabled as well.
- 2.When in fire mode, all keypad command are ignored.(Including RUN,STOP and JOG commands).
- 3.When in fire mode, all RS-485 communication commands are ignored.(Including RUN, STOP and JOG commands)
- 4.When in fire mode, the JOG command is invalid.(JOG command source: keypad, external terminals and communications.) Any operating JOG command is invalid automatically.

Protection parameter group 06

5. When in fire mode, the inverter does not execute PID function. Any operating PID function is invalid automatically.
6. When in fire mode, the inverter does not execute the starting DC brake function. Any operating DC brake is invalid automatically when in fire mode.
7. When in fire mode, the inverter does not execute over-current stall prevention function. Any operating over-current stall prevention is automatically invalid when in fire mode.
8. When in fire mode, if low voltage, the inverter keeps running or stopped when no power.
9. When in fire mode, the output stop function (MRS,P_MRS) is invalid.
10. When in fire mode, the operating frequency for 06-85(P.208) cannot be larger than 01-00(P.1).if 06-85(P.208) larger than 01-00 (P.1) , the maximum frequency is automatically set to 01-00 (P.1)

5.8 Communication parameter group 07

Group	Parameter number	Name	Setting range	Default	Page
07-00	P.33	Communication protocol selection	0 : Modbus protocol	1	120
			1 : Shihlin protocol		
07-01	P.36	Inverter communication station number	0 ~ 254	0	120
07-02	P.32	Serial communication baud rate	0 : baud rate :4800bps	1	120
			1 : baud rate :9600bps		
			2 : baud rate :19200bps		
			3 : baud rate :38400bps		
			4 : baud rate :57600bps		
5 : baud rate :115200bps					
07-03	P.48	Data length	0 : 8bit	0	120
			1 : 7bit		
07-04	P.49	Stop bit length	0 : 1bit	0	120
			1 : 2bit		
07-05	P.50	Parity check selection	0 : No parity check	0	120
			1 : Odd		
			2 : Even		
07-06	P.51	CR/LF selection	1: CR only	1	120
			2 : Both CR and LF		
07-07	P.154	Modbus communication format	0 : 1、7、N、2 (Modbus, ASCII)	4	120
			1 : 1、7、E、1 (Modbus, ASCII)		
			2 : 1、7、O、1 (Modbus, ASCII)		
			3 : 1、8、N、2 (Modbus, RTU)		
			4 : 1、8、E、1 (Modbus, RTU)		
			5 : 1、8、O、1 (Modbus, RTU)		
6 : 1、8、N、1 (Modbus, RTU)					
07-08	P.52	Number of communication retries	0 ~ 1000	5	120
07-09	P.53	Communication interval allowed time	0 ~ 999.8s : Check communication timeout with the set value	99999	120
			99999 : No timeout check		
07-10	P.153	Communication alarm action	0 : Alarm and stop freely	0	120
			1 : No alarm and continuing to operation		
07-11	P.34	Communication EEPROM write-in selection	0 : When writing parameters through communication, write in RAM and EEPROM	0	135
			1 : When writing parameters through communication, only write into RAM		

5.8.1 Shihlin protocol and Modbus protocol

- These protocols can link and communicate with upper controller through RS485 communication port of inverter for parameter setting, monitoring, etc.

Parameter	Name	Default	Setting Range	Content
07-00 P.33	Communication protocol selection	1	0	Modbus protocol
			1	Shihlin protocol
07-01 P.36	Inverter communication station number	0	0 ~ 254	Maximum inverter connect number is determined by wiring method and impedance matching. Please set its value to a non-zero value when using Modbus protocol
07-02 P.32	Serial communication baud rate	1	0	Baud rate: 4800bps
			1	Baud rate: 9600bps
			2	Baud rate: 19200bps
			3	Baud rate: 38400bps
			4	Baud rate: 57600bps
07-03 P.48	Data length	0	0	8 bit
			1	7 bit
07-04 P.49	Stop bit length	0	0	1 bit
			1	2 bit
07-05 P.50	Parity check selection	0	0	No parity check
			1	Odd
			2	Even
07-06 P.51	CR/LF selection	1	1	CR only
			2	Both CR and LF
07-07 P.154	Modbus communication format	4	0	1、7、N、2 (Modbus, ASCII)
			1	1、7、E、1 (Modbus, ASCII)
			2	1、7、O、1 (Modbus, ASCII)
			3	1、8、N、2 (Modbus, RTU)
			4	1、8、E、1 (Modbus, RTU)
			5	1、8、O、1 (Modbus, RTU)
07-08 P.52	Number of communication retries	5	0 ~ 1000	If communication error times exceed set value of 07-08 (P.52) and 07-10 (P.153) is set to 0, alarm OPT will be reported.
			99999	No timeout check
07-09 P.53	Communication interval allowed time	99999	0 ~ 999.8s	Checking communication timeout with the set value
			99999	No timeout check
07-10 P.153	Communication alarm action	0	0	Alarm and stop freely
			1	No alarm and continuing to operation

Setting Shihlin protocol and Modbus protocol

- ◆ If any communication parameter is changed, please power off and restart inverter.
- ◆ SC3 series inverters offer two protocols to choose from: Shihlin protocol and Modbus protocol. Parameters 07-02(P.32), 07-01(P.36), 07-08(P.52), 07-09(P.53), 07-10(P.153) are for both protocols. Parameter 07-03(P.48)~07-06(P.51) only applies to Shihlin protocol and parameter 07-07 (P.154) applies only to Modbus protocol. Please refer to communication protocol for details.

Note:1. Maximum inverter connect number is determined by wiring method and impedance matching. Please set station number value to non-zero when using Modbus protocol.

2. If communication error times exceed set value of 07-08(P.52), and 07-10(P.153) is set to 0, OPT alarm will trigger.

3. Modbus protocol is expressed according to start bit, data bit, parity check bit and stop bit. In addition, N means no parity check, E means 1-bit even check, and O means 1-bit odd check.

4. In Shihlin protocol, please check the settings of parameter 07-03~07-05(P.48~P.50).If 07-04(P.49) is set to 1(stop bit 2 bit) , set 07-05(P.50) to 0 and select no parity check ; the format of 07-03(P.48)=1, 07-04(P.49)= 07-05 (P.50)=0 is unusable.

✓ Composition and wiring of SC3 RS485 communication interface

1. Terminal configuration of SC3 RS485 communication interface

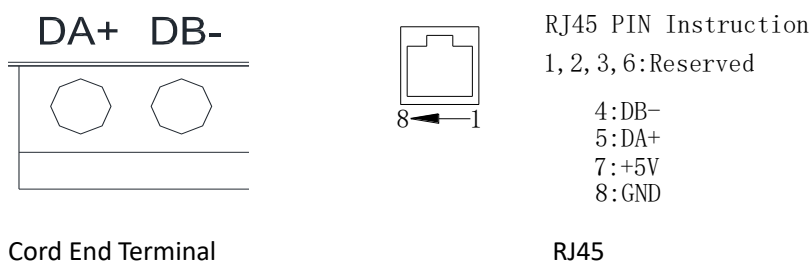

2. Communication between upper controller and a single inverter (take PLC as an example)

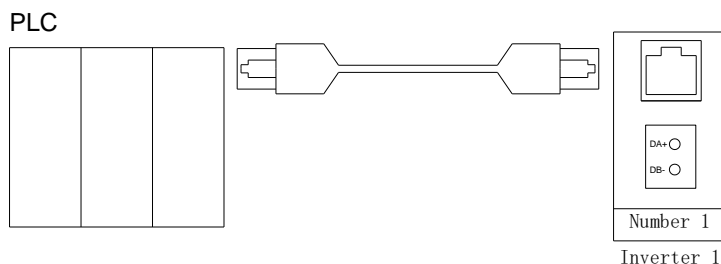

3. Communication between upper controller and multiple inverters (take PLC as an example)

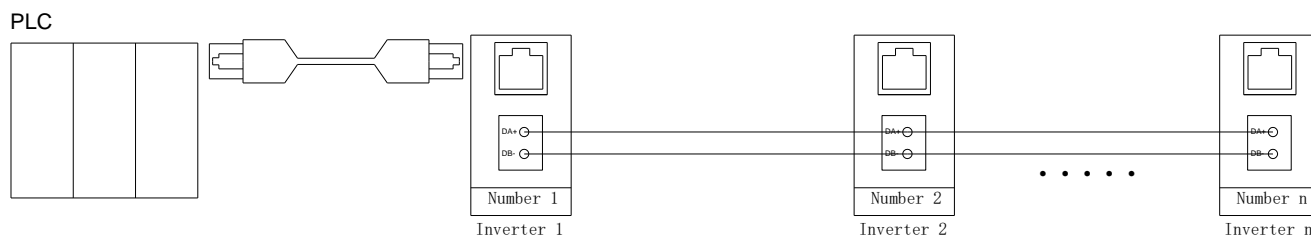

4. SC3 series inverter support Shihlin communication protocol and MODBUS communication protocol

✓ Shihlin protocol

1. Upper controller and inverter automatically converted into ASCII code (hexadecimal) for communication.
2. Please follow the steps to perform data communication between upper controller and inverter.

Communication parameter group 07

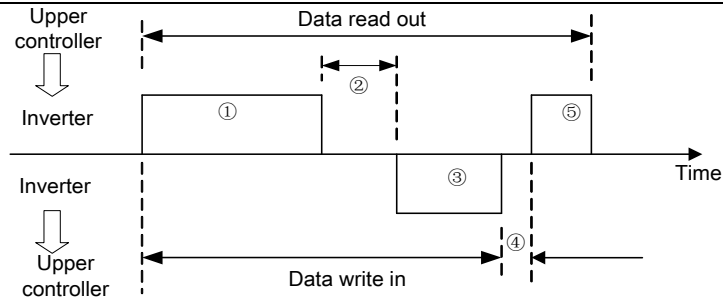

Please refer to the following table for descriptions of communication actions and communication data format type in the above steps:

No	Action	Run command	Frequency write	Parameter write	Inverter reset	Monitoring	Parameter readout	
①	Upper controller user program sends a communication request to inverter	A	A	A	A	B	B	
②	Inverter data processing time	Yes	Yes	Yes	Yes	Yes	Yes	
③	Inverter return information (check data ① for error)	No error (accept request)	C	C	C	No	E	E
		Error (request denied)	D	D	D	No	D	D
④	Upper controller processing delay time	No	No	No	No	No	No	

①Data of communication request sent by upper controller to inverter

Format	Data number													
	1	2	3	4	5	6	7	8	9	10	11	12	13	14
A (Data write)	ENQ *1)	Inverter station number		Command code	Waiting time *2)		Data				Check code Sum check*7)		End symbol*3)	
B (Data read)	ENQ *1)	Inverter station number		Command code	Waiting time *2)		Check code Sum check*7)		Check code Sum check*7)					

③Inverter return information

Data write-in

Format	Data number							
	1	2	3	4	5	6		
C (correct)	ACK*1)		Inverter station number		End symbol*3)			
D (error)	NAK*1)		Inverter station number		Error code*5)		End symbol*3)	

Data read-out

Format	Data number												
	1	2	3	4	5	6	7	8	9	10	11	12	13
E(correct)	STX*1)	Inverter station		Data read-out				Unit*4)	ETX	Check code Sum check*7)		End symbol*3)	
D(error)	NAK*1)	Inverter station		Error code*5)	End symbol*3)								

*1) Control code

Signal	ASCII code	Content	Signal	ASCII Code	Content
NUL	H00	NULL	ACK	H06	Acknowledge
STX	H02	Start of Text	LF	H0A	Line Feed
ETX	H03	End of Text	CR	H0D	Carriage Return
ENQ	H05	Enquiry	NAK	H15	Negative Acknowledge

*2) Waiting time set from 0 to 15 with 10ms unit. Example: set value 5 --->50ms.

*3) End symbol (CR, LF codes)

When performing data communication from upper controller to inverter, CR and LF codes at the end of message will be automatically set according to upper controller mode. At this time, inverter must also make necessary settings to cooperate with upper controller. If only CR is selected, only one register is occupied; If both CR and LF are selected, two registers will be occupied.

*4) Unit: 0---> Unit 1, 1---> Unit 0.1, 2---> Unit 0.01, 3---> Unit 0.001

*5) Error code :

Error code	Error item	Communication error content
H01	Parity check error	Parity check of data received by inverter is different from parity check initially set
H02	Sum Check error	Sum Check value calculated by inverter according to received data is different from received Sum Check value
H03	Communication protocol error	Structure of the data received by inverter is incorrect; or data has not been received within specified time; or CR and LF codes are different from those initially set
H04	Frame error	Stop bit of data received by inverter is inconsistent with stop bit initially set
H05	Overflow error	When inverter is receiving data (not all data have been received yet), upper controller transmits next data to it.
H0A	Wrong mode	Write when inverter is running or mode setting requirements are not met
H0B	Command code error	A command code that cannot be processed by inverter is specified
H0C	Data range error	When setting parameters and frequencies, data outside the set range are specified

*6) When the parameter has the characteristics of 99999, the write-in or read-out of 99999 will be replaced by HFFFF

*7) Request sum check code

ASCII-converted code of the data is added in binary code, and the lower bit (lower 8 bits) of the result (summation) is converted to ASCII 2 bits (hexadecimal), which is called SumCheck Code.

✓ Communication example:

Example 1. Upper controller sends a forward rotation command to inverter:

Step 1: Use the upper controller to send a FA command in Format A :

ENQ	Inverter station Number 0	Command code HFA	Waiting time	data H0002	Check code Sum Check	CR
H05	H30 H30	H46 H41	H30	H30 H30 H30 H32	H44 H39	H0D

Sum Check calculation : $H30 + H30 + H46 + H41 + H30 + H30 + H30 + H30 + H32 = H1D9$, take the lower eight bits D9 to convert to ASCII code H44 and H39

Step 2: After receive and processing the data without error, inverter will send reply to upper controller in Format C:

ACK	Inverter station number 0	CR
H06	H30 H30	H0D

Example 2. Upper controller sends a stop rotation command to inverter:

Step 1: Use upper controller to send FA command in Format A :

ENQ	Inverter station number 0	Code HFA	Waiting time	Data H0000	Check code Sum Check	CR
H05	H30 H30	H46 H41	H30	H30 H30 H30 H30	H44 H37	H0D

Step 2: After receive and processing the data without error, inverter will send reply to upper controller in Format C :

ACK	Inverter station number 0	CR
H06	H30 H30	H0D

Example 3. Upper controller reads the value of 01-28(P.162) :

Step1: Upper controller sends write and page change command, using Format A :

ENQ	Inverter station number 0	Code HFF	Waiting time	Data H0001	Check code Sum Check	CR
H05	H30 H30	H46 H46	H30	H30 H30 H30 H31	H44 H44	H0D



P.162 is on page 1

Step 2: After receive and processing the data without error, inverter will send reply to upper controller in Format C :

ACK	Inverter station number 0	CR
H06	H30 H30	H0D

Step 3: Upper controller requests inverter for reading 01-28(P.162) value using Format B :

ENQ	Inverter station number 0	Code H3E	Waiting time	Check code Sum Check	CR
H05	H30 H30	H33 H45	H30	H30 H38	H0D



Subtract 100 from 162 (=62), convert 62 to H3E in hex , then convert 3 , E to H33, H45 in ASCII

Step 4: Once inverter receives and processes the data without error, 01-28(P.162) value will be sent to upper controller in Format E:

STX	Inverter station number 0	Read out data HFFFF	Unit	ETX	Check data Sum Check	CR
H02	H30 H30	H46 H46 H46 H46	H32	H03	H41 H41	H0D

Example 4. Change the content of 01-28(P.162) to 50 (Default setting is 99999).

Step 1~2 are the same as Step 1~2 of Example 3;

Step 3: Upper controller requests inverter to write 50 in 01-28(P.162) in Format A :

ENQ	Inverter station number 0	Reference code HBE	Waiting time	Data H1388	Check code Sum Check	CR
H05	H30 H30	H42 H45	H30	H31 H33 H38 H38	H45 H42	H0D



Subtract 100 from 162(=62) ,
Convert 62 to H3E in hex ,
H3E+H80=HBE

minimum unit of 01-28 is 0.01, hence 50×100=5000,
then convert 5000 to H1388 in hex,
then convert 1、3、8、8 to ASCII for transmission

Step 4: After receive and processing the data without error, inverter will send reply to upper controller in Format C :

ACK	Inverter station number 0	CR
H06	H30 H30	H0D

Example 5. Write 600 into 01-28(P.162) (this parameter range is set from 0 to 599.00)

Step 1~2 are the same as Step 1~2 of Example 3;

Step 3: Upper controller requests inverter to write 600 in 01-28(P.162) in Format A:

ENQ	Inverter station number 0	Reference code HBE	Waiting time	Data HEA60	SUM CHECK	CR
H05	H30 H30	H42 H45	H30	H45 H41 H36 H30	H30 H33	H0D

Step 4: After receiving and processing the data, the data exceed the range of 01-28(P.162), so data range is incorrect. Inverter will reply error to upper controller in Format D :

NAK	Inverter station number 0	Error code H0C	CR
H15	H30 H30	H43	H0D

Note: In above examples, parameters 01-28 (P.162) reading and writing are all using P parameter mode. To use parameter group mode, please note the difference between page number and parameter number. Please refer to the communication command list for relevant contents.

- ✓ MODBUS communication protocol
- ✓ Message format

MODBUS serial transmission can be divided into two types: ASCII (American Standard Code for Information Interchange) and RTU(Remote Terminal Unit)

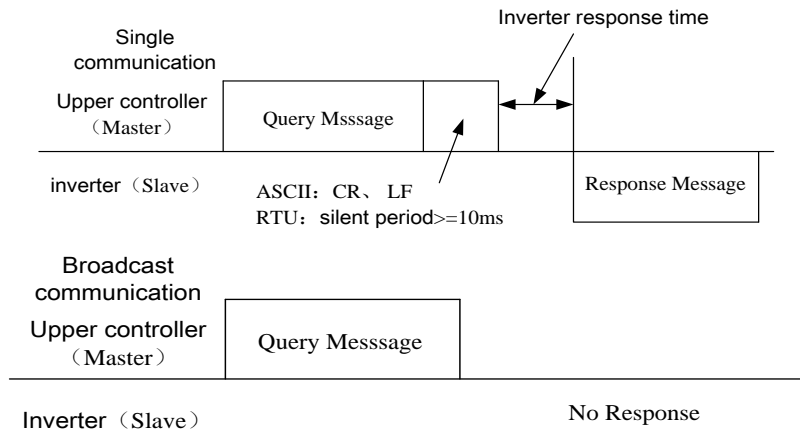

(1) Query

Upper controller (master address) sends data to Slave (slave address) with specified address.

(2) Normal Response

After receiving the query from Master, Slave will execute requested function and ask Master to send normal response.

(3) Error Response

When receiving wrong function codes, address or data, inverter will send this response to Master.

(4) Broadcast

After Master specifies address 0, it can send data to all Slave. All Slave that received Master data will perform the requested function but will not return a respond to Master.

- ✓ Communication format :

In general, Master sends Query Message to Slave, which returns Response Message to Master. During normal communication, address codes and function codes are copied. During abnormal communication, function code bit7 is set to "1" (=H80), and Data Byte is set to error code.

Communication parameter group 07

✓ Message compensation :

Format	Start	① Address	② Function	③ Data	④ Error check	Stop
ASCII	H3A	8bit	8bit	n×8bit	2×8bit	0D 0A
RTU	>=10ms					>=10ms

Message	Content															
①Address information group	Setting range: 0~254. 0 is for broadcast address, 1~254 for slave device (inverter) address. 07-01 (P.36) is used to set the Slave device address when Master device sends information to the Slave device and the Slave device replies information to Master device															
②Function information group	At present, there are four functions. Slave device acts according to the request of Master device. If Master device sets a function code other than the table below, Slave device will return an error response. Normal function code will be returned when response is normal, and H80+ function code will be returned when response is wrong. <table border="1" style="width: 100%; margin-top: 10px;"> <thead> <tr> <th>Function name</th> <th>Function code</th> <th>Function description</th> </tr> </thead> <tbody> <tr> <td>Read multiple registers</td> <td>H03</td> <td>Read Slave's continuous register content.</td> </tr> <tr> <td>Write single register</td> <td>H06</td> <td>Write data into Slave's single register.</td> </tr> <tr> <td>Function diagnosis</td> <td>H08</td> <td>Function diagnosis(only for communication check)</td> </tr> <tr> <td>Write multiple registers</td> <td>H10</td> <td>Data can be written to Slave's multiple registers.</td> </tr> </tbody> </table>	Function name	Function code	Function description	Read multiple registers	H03	Read Slave's continuous register content.	Write single register	H06	Write data into Slave's single register.	Function diagnosis	H08	Function diagnosis(only for communication check)	Write multiple registers	H10	Data can be written to Slave's multiple registers.
Function name	Function code	Function description														
Read multiple registers	H03	Read Slave's continuous register content.														
Write single register	H06	Write data into Slave's single register.														
Function diagnosis	H08	Function diagnosis(only for communication check)														
Write multiple registers	H10	Data can be written to Slave's multiple registers.														
③Data information group	Change according to function code, including initial address, number of registers written and read, data written, etc.															
④Error checking information group	ASCII is the check method for LRC, while RTU is the check method for CRC															

Calculation of LRC check value in ASCII mode:

LRC check is relatively simple, which is used in ASCII mode and can detect all contents in the information domain except the starting colon and the ending carriage return character, it superimpose each data to be transmitted according to bytes (not ASCII code). If the obtained result is greater than hexadecimal H100, remove the excess part (for example, if hexadecimal H136 is obtained, only retain H36), obtain the inverse code of the remaining part and add 1 to it.

Calculation of CRC check value in RTU mode:

1. Add a 16-bit register with every bit set to 1.
2. Perform an xor operation between the upper byte of the 16-bit register and the initial 8-bit byte, the result of which is put into this 16-bit register.
3. Move this 16-bit register one bit to the right.
4. If the bit moved to the right (marked bit) is 1, perform an xor operation between the generated polynomial 1010000000000001 with this register. If the bit moved to the right is 0, 3 will be returned.
5. Repeat steps 3 and 4 until 8 bits are removed.
6. Perform an xor operation between another 8 bits with this 16-bit register.
7. Repeat steps 3 to 6 until all bytes of the message are performed xor operation with the 16-bit register and bit has been moved for 8 times.
8. The content of this 16-bit register is the 2-byte CRC error check code, which will be added to the highest significant bit of the message.

When adding CRC to the message, the low byte is added first, then the high byte.

✓ Communication format:

1. Data readout (H03)

Mode	Start	Address*1)	Function*2)	Start address*3)	Number of register*4)	Check	Stop
ASCII	H3A	2char	2char	4char	4char	2char	0D 0A
RTU	>=10ms	8bit	8bit	2byte	2byte	2byte	>=10ms

Normal response

Mode	Start	Address*1)	Function*2)	Readout data number*5)	Readout data*6)	Check	Stop
ASCII	H3A	2char	2char	2char	4char ...2N×8bit	2char	0D 0A
RTU	>=10ms	8bit	8bit	1byte	2byte ...N×8bit	2byte	>=10ms

Message	Content
*1)Address	Set the address for sending information, 0 is invalid
*2)Function code	H03
*3)Start address	Set the address of the register to be read
*4)Number of registers	Set the number of registers to be read. The maximum number is 20.
*5)Read data number	Twice as much as *4)
*6)Read data	Set the data specified in *4)and read the data from high byte to low byte.

2. Data write in (H06)

Mode	Start	Address*1)	Function*2)	Start Address*3)	Write-in data*4)	Check	Stop
ASCII	H3A	2char	2char	4char	4char	2char	0D 0A
RTU	>=10ms	8bit	8bit	2byte	2byte	2byte	>=10ms

Normal response

Mode	Start	Address*1)	Function*2)	Start Address*3)	Write-in data*4)	Check	Stop
ASCII	H3A	2char	2char	4char	4char	2char	0D 0A
RTU	>=10ms	8bit	8bit	2byte	2byte	2byte	>=10ms

Message	Content
*1)Address	Set the address for sending information
*2)Function code	H06
*3)Start address	Set as the start address of the register that needs to be written
*4)Write data	Write data to the specified register, fixed at 16bit.

Note: The content of normal response is the same as query information

3. Write multiple registers (H10)

Mode	Start	Address *1)	Function *2)	Start Address *3)	Number of register *4)	Data*5)	Write-in data *6)	Check	Stop
ASCII	H3A	2char	2char	4char	4char	2char	4char ...2N×8bit	2char	0D 0A
RTU	>=10ms	8bit	8bit	2byte	2byte	1byte	2byte ...N×16bit	2byte	>=10ms

Communication parameter group 07

Normal response

Mode	Start	Address*1)	Function*2)	Start Address*3)	Number of register *4)	Check	Stop
ASCII	H3A	2char	2char	4char	4char	2char	0D 0A
RTU	>=10ms	8bit	8bit	2byte	2byte	2byte	>=10ms

Message	Content
*1)Address	Set the address for sending information
*2)Function code	H10
*3)Start address	Set as the start address for the register that needs to be written
*4) Number of registers	Sets the number of registers written. The maximum number is 12.
*5) Number of data	Setting range is 2~24. Set 2 times the value specified in *4).
*6) Write data	Set data division specified in *4). Write data is set in the order of high byte to low byte. Setting is performed in the order of starting address data, starting address +1 data, starting address +2 data ...

4. Function diagnosis (H08)

In order to send the query information, the query information (function of subfunction code H00) is returned as it is, and communication check can be performed.

Sub-function code H00 (return of query data)

The query information

Mode	Start	Address*1)	Function*2)	Subroutine *3)	Data *4)	Check	End
ASCII	H3A	2char	2char	4char	4char	2char	0D 0A
RTU	>=10ms	1byte	1byte	2byte	2byte	2byte	>=10ms

Normal response

Mode	Start	Address*1)	Function*2)	Sub-function *3)	Data *4)	Check	End
ASCII	H3A	2char	2char	4char	4char	2char	0D 0A
RTU	>=10ms	1byte	1byte	2byte	2byte	2byte	>=10ms

Query information setting

Message	Content
*1)Address	Set the address for sending information, but be unable to broadcast communication (0 is invalid)
*2)Function code	H08
*3)Sub-function code	H0000
*4)Data	The data can be set arbitrarily if the length is 2 byte. Set range is H0000~HFFFF.

5. Error response

If error is contained in the function/address/data received from the device, do function diagnosis;

However, when using function code H03 or H10 to access more than one address, if one or more data can still operate, it will not be seen as an error.

Mode	Start	Address*1)	Function*2) H80+function	Error code * 3)	Check	End
ASCII	H3A	2char	2char	2char	2char	0D 0A
RTU	>=10ms	8bit	8bit	8bit	2byte	>=10ms

Message	Content
*1) Address	Set the address for sending information
*2) Function code	Function code set by Master + H80
*3)Error code	Set code in the following table

Error code list:

Source	Code	Meaning	Remarks
Slave reply	H01	illegal function code	In query data sent by Master, the function code cannot be processed by slave device. Function codes are not H03, H06, H08, H10 (Suppose).
	H02	illegal data address	In query data sent by Master, the address cannot be processed by Slave (outside the addresses listed in the table, the reserved parameters, the parameters not allowed to be read, the parameters not allowed to be written).
	H03	illegal data value	In query data sent by Master, the data cannot be processed by the Slave (outside parameter writing range, required specified mode, other error, etc.).

Note: When read multiple parameters, if there is at least one readable data, it is not an error if there are reserved parameters within.

In data sent by Master, Slave (inverter) will detect the following errors, but will not respond when it detects the error.

Error detection item table:

Error item	Error content
Parity error	The parity test for data received by the inverter is different from the parity test set at the initial stage.
Frame error	The stop byte of the data received by the inverter mismatches the stop byte set at the initial stage.
Overflow error	When the inverter is receiving data, the host computer sends the next set of data before the inverter finishes receiving the current one.
Error test	The LRC/CRC calculated by the inverter according to the received data is different from the received LRC/CRC.

✓ Communication example

Example 1. CU operation mode written by communication

Step 1: Upper controller modifies operation mode of inverter

Mode	Start	Address	Function	Start address		Write data		Check	Stop
ASCII	H3A	H30 H31	H30 H36	H31 H30	H30 H30	H30 H30	H30 H30	H45 H39	0D 0A
RTU	>=10ms	01	06	10	00	00	00	8D 0A	>=10ms

Step 2: After receiving and processing the data without error, inverter will send a reply to upper controller

Mode	Start	Address	Function	Start address		Write data		Check	Stop
ASCII	H3A	H30 H31	H30 H36	H31 H30	H30 H30	H30 H30	H30 H30	H45 H39	0D 0A
RTU	>=10ms	01	06	10	00	00	00	8D 0A	>=10ms

Example 2. Read parameter 01-28 (P.162) value by upper controller

Step 1: Upper controller sends message to inverter to read 01-28 (P.162) value. 01-28 (P.162) address is H00A2.

Mode	Start	Address	Function	Start address		Number of registers		Check	Stop
ASCII	H3A	H30 H31	H30 H33	H30 H30	H41 H32	H30 H30	H30 H31	H35 H39	0D 0A
RTU	>=10ms	01	03	00	A2	00	01	25 E8	>=10ms

Communication parameter group 07

Step 2: After receive and processing the data without error, inverter will send 01-28 (P.162) to upper controller.

Mode	Start	Address	Function	Number of data read	Read data		Check	Stop
ASCII	H3A	H30 H31	H30 H33	H30 H32	H46 H46	H46 H46	H46 H43	0D 0A
RTU	>=10ms	01	03	02	FF	FF	B9 F4	>=10ms

Example 3. Upper controller change inverter 01-28 (P.162) value to 50.

Step 1: Upper controller sends message to inverter to write 50 into 01-28 (P.162) .

Mode	Start	Address	Function	Start address		Write data		Check	Stop
ASCII	H3A	H30 H31	H30 H36	H30 H30	H41 H32	H31 H33	H38 H38	42 43	0D 0A
RTU	>=10ms	01	06	00	A2	13	88	25 7E	>=10ms

Step 2: After receive and processing the data without error, inverter will send a reply to upper controller

Mode	Start	Address	Function	Start address		Write data		Check	Stop
ASCII	H3A	H30 H31	H30 H36	H30 H30	H41 H32	H31 H33	H38 H38	H42 H43	0D 0A
RTU	>=10ms	01	06	00	A2	13	88	25 7E	>=10ms

Example 4. Upper controller read parameters 01-10(P.0), 01-00(P.1), 01-01(P.2), 01-03(P.3), 04-00~04-02/P.4~P.6, 01-06~01-07/P.7~P.8, 06-00(P.9), 10-00~10-01/P.10~P.11.

Step 1: Upper controller sends message to inverter for reading 01-10(P.0), 01-00(P.1), 01-01(P.2), 01-03(P.3), 04-00~04-02/P.4~P.6, 01-06~01-07/P.7~P.8, 06-00(P.9), 10-00~10-01 /P.10~P.11 value. Start address is H0000.

Mode	Start	Address	Function	Start address		Number of registers		Check	Stop
ASCII	H3A	H30 H31	H30 H33	H30 H30	H30 H30	H30 H30	H30 H43	H46 H30	0D 0A
RTU	>=10ms	01	03	00	00	00	0C	45 CF	>=10ms

Step 2: After receive and processing the data without error, inverter will send a reply to upper controller

Mode	Start	Address	Function	Start address		Number of registers		Check	Stop
ASCII	H3A	H30 H31	H30 H33	H31 H38		...12×4 char		2char	0D 0A
RTU	>=10ms	01	03	18		...12×2 byte		2byte	>=10ms

Example 5. Upper controller write parameters 01-10(P.0), 01-00(P.1), 01-01(P.2), 01-03(P.3), 04-00~04-02/P.4~P.6, 01-06~01-07/P.7~P.8, 06-00(P.9), 10-00~10-01/P.10~P.11.

Step 1: Upper controller sends message to inverter for writing 01-10(P.0), 01-00(P.1), 01-01(P.2), 01-03(P.3), 04-00~04-02/P.4~P.6, 01-06~01-07/P.7~P.8, 06-00(P.9), 10-00~10-01/P.10~P.11

Mode	Starting	Address	Function	Start address		Number of registers		Data volume	Write-in data	Check	Stop
ASCII	H3A	H30 H31	H31 H30	H30 H30	H30 H30	H30 H30	H30 H43	H31 H38	...N×4 char	2char	0D 0A
RTU	>=10ms	01	10	00	00	00	0C	18	...N×2byte	2byte	>=10ms

Step 2: After receive and processing the data without error, inverter will send a reply to upper controller

Mode	Start	Address	Function	Start address		Number of registers		Check	Stop
ASCII	H3A	H30 H31	H31 H30	H30H30	H30 H30	H30 H30	H30 H43	H45 H33	0D 0A
RTU	>=10ms	01	10	00	00	00	0C	00 18	>=10ms

Note: In above examples, parameters 01-28 (P.162) reading and writing are all using P parameter mode. To use parameter group mode, please note the difference in address. Please refer to the communication command list for relevant contents.

◆ Communication command list

Set the following command codes and data to perform various operation control, monitoring, etc.

Item		Shihlin protocol command code	Modbus command code	Modbus address	Data content and function description																
Operation mode read out		H7B	H03	H1000	H0000: Communication mode; H0001: External mode; H0002: JOG Mode; H0003: Combined mode 1; H0004: Combined mode 2; H0005: Combined mode 3; H0006: Combined mode 4; H0007: Combined mode 5; H0008: PU Mode;																
Operation mode write in		HFB	H06/H10																		
Inverter status monitoring		H7A	H03	H1001	H0000~H00FF b15 : during tuning b14: during inverter reset b13, b12: Reserved b11: inverter E0 status b10~8: Reserved b7 : alarm occurred b6 : frequency detect b5 : Parameters reset end b4: overload b3: frequency arrive b2: during reverse rotation b1: during forward rotation b0: running																
Target frequency write-in	EEPROM	HEE	H06/H10	H1009	H0000~ HFDE8 : 0~650.00Hz																
	RAM	HED		H1002																	
Special monitor codes read out		H7D	H03	H1013	H0000~H0010: monitor selected information. Please refer to special monitoring code table (H0009 reserved)																
Special monitor codes write in		HF3	H06/H10																		
Monitor external operation		H7C	H03	H1012	H0000~H000F : <table border="1" style="display: inline-table; vertical-align: middle;"><tr><td colspan="4" style="text-align: center;">b15-b4</td><td style="text-align: center;">b3</td><td style="text-align: center;">b2</td><td style="text-align: center;">b1</td><td style="text-align: center;">b0</td></tr><tr><td style="text-align: center;">0000</td><td style="text-align: center;">0000</td><td style="text-align: center;">0000</td><td style="text-align: center;">0000</td><td style="text-align: center;">MRS</td><td style="text-align: center;">STR</td><td style="text-align: center;">STF</td><td style="text-align: center;">RES</td></tr></table>	b15-b4				b3	b2	b1	b0	0000	0000	0000	0000	MRS	STR	STF	RES
b15-b4				b3	b2	b1	b0														
0000	0000	0000	0000	MRS	STR	STF	RES														
Inverter reset		HFD	H06/ H10	H1101	H9696: function of 00-02=2/P.997=1. When communicating with upper controller, inverter cannot return data to upper controller because inverter is reset.																
Parameter clear		HFC	H06/ H10	H1104	H5A5A	Please refer to parameter recovery table for details.															
					H5566																
					H5959																
				H1103	H9966																
				H1106	H9696																
					H99AA																
					H9A9A																
				H1105	H55AA																
H1102	HA5A5																				

Communication parameter group 07

Item	Shihlin protocol command code	Modbus command code	Modbus address	Data content and function description
Parameter read-out	H00~H63	H03	P mode: H0000~H018F Parameter group mode: H2710~H2CFF	1.Please refer to the parameter table for data range and decimal point position 2.Modbus address of each parameter in P parameter mode corresponds to hexadecimal value of parameter number. For example, Modbus address of 04-26 (P.138) is H008A. 3. Modbus address of each parameter in parameter group mode corresponds to hexadecimal value of parameter number +10000. For example, Modbus address of 04-26 (P.138) is 0x28BA.
Parameter write-in	H80~HE3	H06/ H10		
Operation command write	HFA	H06/ H10	H1001	H0000~HFFFF b8~b15 : reserved b7 : Emergency stop (MRS) b6 : Second function (RT) b5 : High speed (RH) b4 : Middle speed (RM) b3 : Low speed (RL) b2 : Reverse(STR) b1 : Forward (STF) b0 : reserved
Monitor inverter real time value	---	H03	H1014~H1020	Modbus address is as follows : H1014 : digital input terminal state H1015 : digital output terminal state H1016 : reserved H1017 : terminal 3-5 input current/voltage H1018 : reserved H1019 : DC bus voltage H101A: inverter electronic thermal accumulation rate H101B: inverter output wattage H101C: inverter temperature rising accumulation rate H101D: inverter NTC temperature accumulation rate H101E: motor electronic thermal accumulation rate H101F: PID control target pressure H1020: PID control feedback pressure

Item		Shihlin protocol command code	Modbus command code	Modbus address	Data content and function description					
Page change for parameter reading and writing	Read	H7F	---	---	P parameter mode : H0000 : P.0~P.99 ; H0001 : P.100~P.199 ; H0002 : P.200~P.299 ; H0003 : P.300~P.399 ; Parameter group mode : H0064 : 00-00~00-99 ; H006B: 07-00~07-99 H0065 : 01-00~01-99 ; H006C: 08-00~08-99 H0066 : 02-00~02-99 ; H006E: 10-00~10-99 H0067 : 03-00~03-99 ; H006F: 11-00~11-99 H0068 : 04-00~04-99 ; H0071: 13-00~13-99 H0069 : 05-00~05-99 ; H0073: 15-00~15-99 H006A : 06-00~06-99					
	Write	HFF								
Monitor	Frequency	EEPROM	H73	H03	H1009	H0000~HFDE8(two decimal points when (00-08(P.37)=0; one decimal point when non-zero)				
		RAM	H6D		H1002					
	Output frequency		H6F		H1003	H0000~H9C40 (same as above)				
	Output current		H70		H1004	H0000~HFFFF(two decimal points)				
	Output voltage		H71		H1005	H0000~HFFFF(two decimal points)				
	Error code	H74			H1007	H0000~HFFFF : last two alarm error code H74/H1007 : Error code 1 and 2 ; b15 b8 b7 b0 <table border="1" style="width: 100%; border-collapse: collapse;"> <tr> <td style="width: 50%;">Error code 2</td> <td style="width: 50%;">Latest error code</td> </tr> </table> H75/H1008 : Error code 3 and 4; b15 b8 b7 b0 <table border="1" style="width: 100%; border-collapse: collapse;"> <tr> <td style="width: 50%;">Error code 4</td> <td style="width: 50%;">Error code 3</td> </tr> </table> For the alarm codes please refer to the alarm code table in the alarm record parameters 06-40(P.288)~06-43(P.291)	Error code 2	Latest error code	Error code 4	Error code 3
		Error code 2	Latest error code							
		Error code 4	Error code 3							
		H75			H1008					

Communication parameter group 07

◆ Table for parameter recovery

Data content	P parameter operation	Communication p parameter (Note 1)	Table 1 (Note 2)	Table 2 (Note 2)	User registered parameter	Other P parameter	Error code
H5A5A	00-02=4(P.999=1)	o(Note 3)	x(Note 4)	x	o	o	x
H5566	00-02=5(P.999=2)	o	x	o	x	o	x
H5959	00-02=6(P.999=3)	o	x	x	x	o	x
H9966	00-02=3(P.998=1)	o	x	o	o	o	x
H9696	Communication 999 1	x	x	x	o	o	x
H99AA	Communication 999 2	x	x	o	x	o	x
H9A9A	Communication 999 3	x	x	x	x	o	x
H55AA	Communication 998	x	x	o	o	o	x
HA5A5	00-02=1(P.996=1)	x	x	x	x	x	o

Note: 1. Communication P parameters includes 07-02(P.32), 07-00(P.33), 07-01(P.36), 07-03(P.48)~ 07-09(P.53), 00-16(P.79), 07-10(P.153) and 07-07(P.154).

2. Table 1 and table 2 refer to Section 5.1.2 table1 and table 2

3. "o" means that parameter can be restored to default value or error can be cleared.

4. "x" means that parameter or error cannot be cleared.

◆ Special monitor code table

Data	Content	Unit
H0000	Monitor digital input terminal state.	Note.1
H0001	Monitor digital output terminal state.	Note.2
H0003	Monitor voltage across terminal 3-5	0.01mA/0.01V
H0005	DC bus voltage	0.1V
H0006	Monitor electronic thermal accumulation rate	---
H0007	Inverter temperature rising accumulation rate	0.01
H0008	Inverter output power	0.01kW
H0009	Inverter NTC temperature accumulation	---
H000A	Motor electronic thermal accumulation rate	---
H000B	PID control target pressure	0.1%
H000C	PID control feedback pressure	0.1%

Note: 1. Digital input terminal state details

b3	b2	b1	b0
M1	M0	STR	STF

2. Digital output terminal state details

b1	b0
A-C	0

5.8.2 Communication EEPROM write selection

➤ Use this function if parameter settings are frequently written by communication

Parameter	Name	Default	Setting Range	Content
07-11 P.34	Communication EEPROM write-in selection	0	0	When writing parameters in communication mode, write in RAM and EEPROM
			1	When writing parameters through communication, only write into RAM

Setting

Communication EEPROM write selection

- ◆ When parameter write in is performed by RS485, parameters can store in EEPROM + RAM or RAM only.
- ◆ If change parameter value frequently, set "1" in 07-11(P.34). When 07-11(P.34) set to "0" EEPROM lifetime will be shorter due to constantly write in.

Note: Set 07-11 (P.34) =1 (RAM only), when the power of inverter is turned off, parameters changed will not be memorized. When power on again, all parameters will still be the setting previously saved in EEPROM.

5.9 PID parameter group 08

Group	Parameter number	Name	Setting range	Default	Page
08-00	P.170	PID function selection	0: Off	0	137
			2 : Parameter 08-03(P.225) as target value, terminal 3-5 current/voltage input as feedback source		
			3 : Target value is set by multi-speed value, and feedback from terminal 3-5 current/voltage input		
08-01	P.171	PID feedback control method	0: Negative feedback control.	0	137
			1: Positive feedback control.		
08-03	P.225	PID target value from keypad	0 ~ 08-43(P.251)	20.0%	137
08-04	P.172	Proportional gain	1~100	20	137
08-05	P.173	Integral time	0 ~ 100.0s	1.0 s	137
08-06	P.174	Differential time	0 ~ 1000ms	0 ms	137
08-07	P.175	Abnormal deviation	0 ~ 200.0%	0.0%	137
08-08	P.176	Abnormal duration time	0 ~ 600.0s	30.0 s	137
08-09	P.177	Abnormal processing mode	0: Stop freely	0	137
			1: Slow down to stop		
			2: Alarm and continue operation		
08-10	P.178	Sleep detection deviation	0 ~ 100.0%	0.0%	137
08-11	P.179	Sleep detection duration time	0 ~ 255.0s	1.0s	138
08-12	P.180	Wake-up level	0 ~ 200.0%	90.0%	138
08-13	P.181	Stop level	0 ~ 120.00Hz	40.00Hz	138
08-14	P.182	Upper integral limit	50Hz system:0 ~ 120.00Hz	50.00Hz	138
			60Hz system:0 ~ 120.00Hz	60.00Hz	
08-15	P.183	Deceleration step length when stable	0 ~ 10.00Hz	0.50Hz	138
08-18	P.223	Analog feedback signal bias	0 ~ 100.0%	0.0%	138
08-19	P.224	Analog feedback signal gain	0 ~ 100.0%	100.0%	138
08-43	P.251	PID pressure range (Bar) setting	1.0~100.0	100.0	141
08-45	P.253	Analog signal feedback loss detection time	0.0~600.0s	0.0s	141
08-46	P.254	Analog signal feedback loss action selection	0 : Alarm AErr and inverter stop freely	0	141
			1 : Slow down to stop then alarm AErr		
			2 : Alarm AErr and continue operation		

5.9.1 PID function selection

- Inverter can control flow, volume or pressure by PID control. By using parameter setting as target source, and with analog signal as feedback source, it forms a closed loop control system.

Parameter	Name	Default	Setting Range	Content
08-00 P.170	PID function selection	0	0	Off
			2	Target depends on 08-03(P.225),feedback depends on 3-5 terminal current/input voltage
			3	Target value is set by multi-speed value, and feedback from terminal 3-5 current/voltage input
08-01 P.171	PID feedback control method	0	0	Negative feedback control
			1	Positive feedback control

Setting PID function selection

- ◆ During PID control, frequency displayed on screen is inverter output frequency.
- ◆ For terminal 3-5 input signal filtering please refer to parameters 02-10(P.60).
- ◆ When 08-00(P.170) set parameter =3, the 16 target pressure value are set by digital input terminal RL , RM, and combination of RH & REX. The default target pressure value is set by 08-03(P.225) parameter. The 1st -15th are set by multi-speed parameter 04-00(P.4)~04-02(P.6)、 04-03(P.24)~04-06(P.27)、 04-07(P.142)~04-14(P.149).
Eg: When 08-00(P.170)=3,04-02(P.6)=25.00,08-43(P.251)=100.0,RL terminal is ON, PID target pressure ratio is 25%.

5.9.2 PID parameter group

- By setting PID parameters users can realize automatic adjustment of process control.

Parameter	Name	Default	Setting Range	Content
08-03 P.225	PID target value from keypad	20.0%	0~08-43(P.251)	When 08-00 (P.170) is set to 2, the target value is set by 08-03(P.225)
08-04 P.172	Proportional gain	20	1~100	This gain determines the proportion controller's response on feedback deviation. The greater the gain, the faster the response. Gain set too high will cause vibration.
08-05 P.173	Integral time	1.0s	0 ~ 100.0s	This parameter determines integral controller's integral time. When integral gain is too high, integral effect will be too weak to eliminate steady state deviation. When integral gain is rather small, the system vibration time will increase, and too small integral gain will cause system unstable.
08-06 P.174	Differential time	0ms	0 ~ 1000ms	This gain determines deviation controller's response to deviation change rate. Appropriate deviation time can reduce overshooting and vibrating between proportion controller and integral controller. Deviation time set too long will cause system vibration.
08-07 P.175	Abnormal deviation	0.0%	0 ~ 200.0%	---
08-08 P.176	Abnormal duration time	30.0s	0 ~ 600.0s	---
08-09 P.177	Abnormal processing mode	0	0	Stop freely
			1	Slow down to stop
			2	Alarm and continue operation

PID parameter group 08

Parameter	Name	Default	Setting Range	Content	
08-10 P.178	Sleep detection deviation	0.0%	0 ~ 100.0%	---	
08-11 P.179	Sleep detection duration time	1.0s	0 ~ 255.0s	---	
08-12 P.180	Wake-up level	90.0%	0 ~ 200.0%	---	
08-13 P.181	Stop level	40.00Hz	0 ~ 120.00Hz	---	
08-14 P.182	Upper integral limit	50.00Hz	0 ~ 120.00Hz	50Hz	When the deviation value accumulated by integral time, need to set an upper limit for deviation accumulation. For example, the upper integral limit of frequency is equal to 01-03(P.3) * 08-14(P.182)
		60.00Hz		60Hz	
08-15 P.183	Deceleration step length when stable	0.50Hz	0 ~ 10.00Hz	When feedback pressure reach stopping deviation value and time (in seconds), inverter will decrease frequency by 08-15 (P.183) value per second	
08-18 P.223	Analog feedback signal bias	0.0%	0 ~ 100.0%	Feedback signal correction ,unify inverter feedback terminal and actual feedback signal to make inverter and display value the same	
08-19 P.224	Analog feedback signal gain	100.0%	0 ~ 100.0%		

Setting

PID parameter group

◆ Calibration instructions for the offset and gain of the analog feedback signal:

- The user does not connect the feedback signal for correction, the corresponding relationship is as follows:

3-5 input analog voltage signal		3-5 input analog current signal	
Correction voltage	Correction ratio	Correction current	Correction ratio
0.1V	08-18(P.223)	4mA	08-18(P.223)
5V	08-19(P.224)	20mA	08-19(P.224)

Note: 1. The default setting corresponds to a range of 0.1~5V. If it does not match the range needed, please set 08-18 (P.223) and 08-19 (P.224). Also need to set 08-00 (P.170) at the end to achieve uniform range.

- To use terminal 3-5 as the PID feedback source, be sure to set 02-20 (P.17) and AVI-ACI switch first, to select the voltage/current for terminal 3-5 signal.

Example 1 : Use 0~7V for feedback signal on terminal 3-5

$$08-18(P.223) = 0.1 / 7 * 100.0 = 1.4$$

$$08-19(P.224) = 5 / 7 * 100.0 = 71.4$$

After setting 08-18 (P.223) and 08-19 (P.224) according to the above calculated value, set 08-00 (P.170)=2, then the range after calibration is 0~7V.

Example 2: Use 0~20mA for feedback signal on terminal 3-5

$$08-18(P.223) = 4 / 20 * 100.0 = 20.0$$

$$08-19(P.224) = 20 / 20 * 100.0 = 100.0$$

After setting 08-18 (P.223) and 08-19 (P.224) according to the above calculated value, set 08-00 (P.170)=2, then the range after calibration is 0~20mA.

2. Needs to calibrate the feedback signal

Adjust the feedback signal to a certain value, calculate the ratio of this value to the feedback range, and then write this ratio value to 08-18 (P.223);

Re-adjust the feedback signal to another value and calculate the ratio of this value to the feedback range, and then write this ratio value to 08-19 (P.224).

Example 1: Feedback range is 0~10kg

Adjust the feedback signal to 4kg, then write 08-18 (P.223) = $(4 / 10) * 100.0 = 40$,

Adjust the feedback signal to 6kg, then write 08-19 (P.224) = $(6 / 10) * 100.0 = 60$.

Note: The user must connect the actual feedback signal for this type of calibration, and must set 08-00 (P.170) = 2 before performing the calibration.

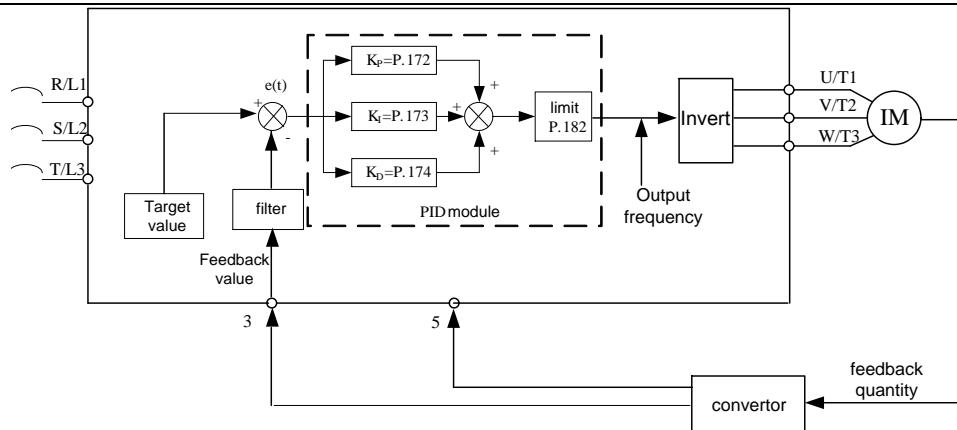

- ◆ When output frequency reaches 01-03 (P.3) * 08-14 (P.182), the feedback value < target value * 08-07 (P.175), and the duration exceeds 08-08 (P.176) , PID is considered abnormal, and it will be handled according to 08-09 (P.177) value.

Example: Set 08-07(P.175)=60%, 08-08(P.176)=30s, 08-09(P.177)=0, 01-03(P.3) = 50Hz, 08- 14(P.182)=100%, when the output frequency reaches 50Hz, the feedback value is lower than 60% of the target value and lasts for 30s, inverter alarms **PID E** and stops freely.

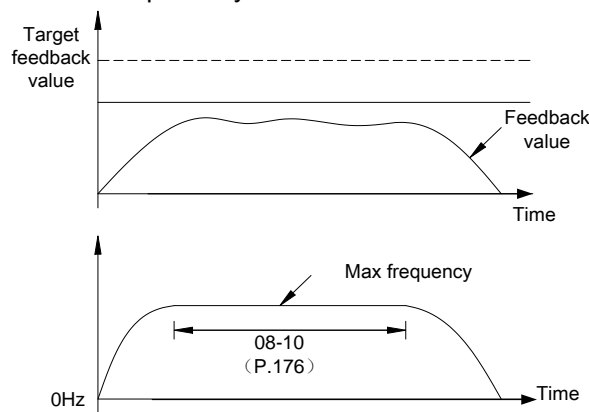

- ◆ If 08-10 (P.178) is set to 0, then 08-11 (P.179), 08-12 (P.180), 08-13 (P.181), 08-15 (P.183) value is invalid. If the value of 08-10 (P.178) is not 0, the PID sleep function will be enabled. When the absolute value of the deviation between the feedback value and the target feedback value is less than the sleep detection deviation and lasts for 08-11 (P.179) sleep detection time, the inverter will gradually reduce the output frequency, when the inverter output frequency is lower than 08-13 (P.181) stop level, inverter will decelerate to stop. When the feedback value is lower than the wake-up level, the inverter output frequency is controlled by PID again.

Example: 08-10(P.178)=5%, 08-11(P.179)=1.0s, 08-12(P.180)=90%, 08-13(P.181)=40Hz, 08-15(P.183)=0.5Hz.
 When the feedback value is greater than 95% of the target feedback value and less than 105% of the target feedback value, it is in stable zone. In the stable zone, inverter reduces the output frequency based on 0.5 Hz per second. When the inverter output frequency is lower than 40 Hz, inverter will directly decelerate to stop. When the feedback value is lower than 90% of the target feedback value, inverter will wake up and the output frequency will be controlled by PID again.

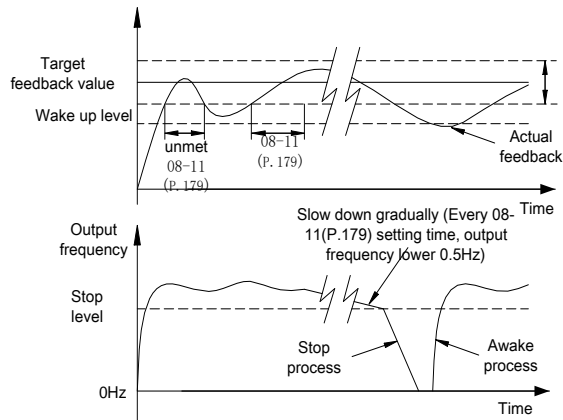

◆ Simple setting of PID gain:

- When the PID target value is changed, if the output response is slow, increase the proportional gain;
 If the output response is fast but unstable, reduce the proportional gain (KP=08-04(P.172)).

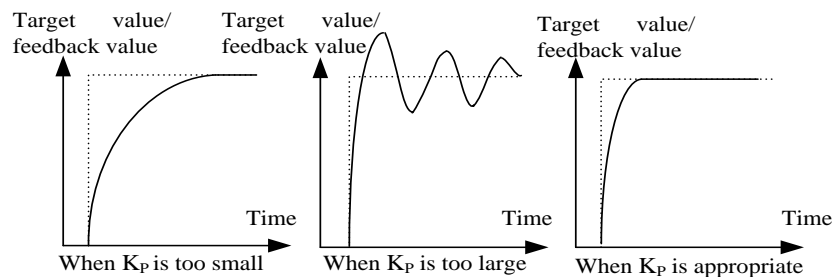

- When PID target and feedback are not equal, reduce the integration time;
 When target and feedback are equal after oscillation, increase the integration time (KI=08-05 (P.173)).

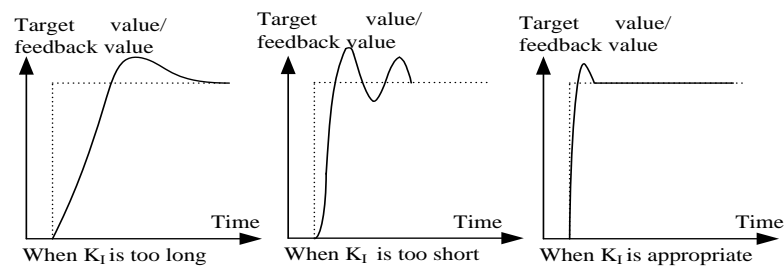

- After increasing the proportional gain, if the output response is still slow, increase the differential gain;
 If the output is unstable, reduce the differential gain (KD=08-06(P.174)).

Note: 1. When 08-09(P.177)=2, there is no alarm display on the keypad, multi-function digital output terminal output a signal. After the inverter stops, the digital output terminal is automatically off.

5.9.3 PID pressure range setting

- Set the range of PID target and feedback.

Parameter	Name	Default	Setting Range	Content
08-43 P.251	PID pressure range (Bar) setting	100.0	1.0~100.0	Set the range of PID target and feedback

Setting PID pressure range

- ◆ The setting of the PID target value can be %, bar, Kg, etc. Set 08-43 (P.251) if need the setting of the PID target value corresponds to the dimension of the actual system, generally set as feedback system sensor range.
- ◆ For example: If the pressure sensor feedback range is 0~10V, the corresponding pressure range is 0~16.0bar, then 08-43 (P.251) set 16.0, and 08-03 (P.225)=8.0, then 00- 07 (P.161) = 3 (monitor target pressure) monitoring is: 8.0.

5.9.4 PID analog signal feedback loss

- Used to detect whether the PID feedback is disconnected.

Parameter	Name	Default	Setting Range	Content
08-45 P.253	Analog signal feedback loss detection time	0.0s	0.0~600.0s	Set the time of feedback disconnect detection, set to 0 to turn off the function
08-46 P.254	Analog signal feedback loss action selection	0	0	Alarm AErr and inverter stop freely
			1	Slow down to stop then alarm AErr
			2	Alarm AErr and continue operation

Setting PID disconnection function

- ◆ Set 08-45 (P.253) to a non-zero value, when inverter is running, PID feedback disconnect exceeds the time set in 08-45 (P.253), inverter react as action set in 08-46 (P.254).
- ◆ Set 08-45 (P.253) to 0, the feedback disconnection detection function is off.

Note: This function is only suitable for 4-20mA terminal 3-5 signal type.

5.10 Application parameter group 10

Group	Parameter Number	Name	Setting Range	Default	Page
10-00	P.10	DC brake operating frequency	0 ~ 120.00Hz	3.00Hz	144
10-01	P.11	DC brake operating time	0 ~ 60.0s	0.5s	144
10-02	P.12	DC brake operating voltage	7.5K/11KF and below model : 0 ~ 30.0%	4.0%	144
			11K/15KF and above model : 0 ~ 30.0%	2.0%	
10-03	P.151	0 ~ 30.0%	0: Off.	0	145
			1: DC voltage braking		
10-04	P.152	Voltage at zero-speed control	7.5K/11KF and below model : 0 ~ 30.0%	5.0%	145
			11K/15KF and above model : 0 ~ 30.0%	2.0	
10-05	P.242	DC brake before inverter start	0: Off	0	145
			1: Before starting operate DC brake first.		
10-06	P.243	DC brake time before inverter start	0 ~ 60.0s	0.5s	145
10-07	P.244	DC brake voltage before inverter start	7.5K/11KF and below model : 0 ~ 30.0%	4.0%	145
			11K/15KF and above model : 0 ~ 30.0%	2.0%	
10-08	P.150	Restart mode selection	X0 : No frequency search.	0	146
			X1 : Reserved		
			X2 : Decrease voltage mode		
			0X : Power on once.		
			1X : Start each time.		
			2X : Only instantaneous stop and restart		
3X : Only valid when the inverter resets in fire mode					
10-09	P.57	Restart idling time	0 ~ 30.0s	99999	146
			99999: Off.		
10-10	P.58	Restart rising time	7.5K/11KF and below model : 0 ~ 60.0s	5.0s	146
			11K/15KF and above model : 0 ~ 60.0s	10.0s	
10-11	P.61	Remote control function	0: Off	0	147
			X1 : Remote control function, frequency save in memory		
			X2 : Remote control function, frequency won't save		
			X3 : Remote control function, frequency won't save, clear frequency setting every time STF/STR "turn off".		
			X4: Remote control function, frequency save in memory every 5s		
			1X:Frequency command range 01-01(P.2)~01-00 (P.1), frequency command value from RH,RM setting		
10-12	P.65	Auto reset function	0: Off.	0	149
			1: When over-voltage, inverter will reset.		
			2: When over-current, inverter will reset.		
			3: When either over-voltage or over-current, inverter will reset.		
			4: When any alarm occurs, inverter will reset.		

Group	Parameter Number	Name	Setting Range	Default	Page
10-13	P.67	Auto reset times	0: Off.	0	149
			1 ~ 10: If the alarm exceeds 10-13(P.67) times, inverter will not reset.		
10-14	P.68	Auto reset waiting time	0 ~ 360.0s	6.0s	149
10-15	P.69	Auto reset times count	Read only	0	149
10-16	P.119	Forward and reverse rotation dead time	0 ~ 3000.0s	0.0s	150
10-17	P.159	Energy-saving control function	0: Off.	0	150
			1: Energy-saving mode.		
10-18	P.229	Dwell function selection	0: Off.	0	151
			1: Backlash compensation function.		
			2: Acceleration and deceleration interrupt waiting function.		
10-19	P.230	Dwell frequency at acceleration	0 ~ 650.00Hz	1.00Hz	151
10-20	P.231	Dwell time at acceleration	0 ~ 360.0s	0.5s	151
10-21	P.232	Dwell frequency at deceleration	0 ~ 650.00Hz	1.00Hz	151
10-22	P.233	Dwell time at deceleration	0 ~ 360.0s	0.5s	151
10-23	P.234	Triangular wave function selection	0: Off.	0	152
			1: If terminal function TRI is triggered, triangular wave function will on.		
			2: Triangular wave function is on at all time.		
10-24	P.235	Maximum amplitude	0 ~ 25.0%	10.0%	152
10-25	P.236	Amplitude compensation at deceleration	0 ~ 50.0%	10.0%	152
10-26	P.237	Amplitude compensation at acceleration	0 ~ 50.0%	10.0%	152
10-27	P.238	Amplitude acceleration time	0 ~ 360.00s/0 ~ 3600.0s	10.00s	152
10-28	P.239	Amplitude deceleration time	0 ~ 360.00s/0 ~ 3600.0s	10.00s	152
10-46	P.268	Voltage stall level	220V : 155 ~ 410V	380V	153
			440V : 310 ~ 820V	760V	
10-55	P.226	Reciprocating machine function selection	0 : Off	0	153
			1 : Turn on reciprocating machine function		
10-56	P.227	Reciprocating forward limit time	0~3600.0s	0.0s	153
10-57	P.228	Reciprocating reverse limit time	0~3600.0s	0.0s	153

5.10.1 DC injection brake

- When stopping the motor, apply DC voltage on motor to stop motor shaft from rotating, users can adjust the DC brake time and braking torque.

Parameter	Name	Default	Setting Range	Content
10-00 P.10	DC brake operating frequency	3.00Hz	0 ~ 120.00Hz	---
10-01 P.11	DC brake operating time	0.5s	0 ~ 60.0s	---
10-02 P.12	DC brake operating voltage	4.0%	0 ~ 30.0%	7.5K/11KF and below model
		2.0		11K/15KF and above model

Setting DC brake

- ◆ After sending stop signal (please refer to chapter 4 for basic operation of starting and stopping the motor), output frequency of inverter will gradually decrease. When the output frequency decreases to “DC brake operation frequency (10-00(P.10))”, DC brake will start to operate.
- ◆ During DC braking, inverter will inject DC voltage into the motor coil to lock the motor rotor. This voltage is called “DC brake operating voltage (10-02(P.12))”. The larger the 10-02(P.12) value, the greater the DC braking voltage, and the better the braking ability. However, the braking current will not exceed inverter rated current.
- ◆ Operation of DC braking will maintain a period of time (10-01(P.11) value) to overcome the inertia from motor rotation.
- ◆ See figure below:

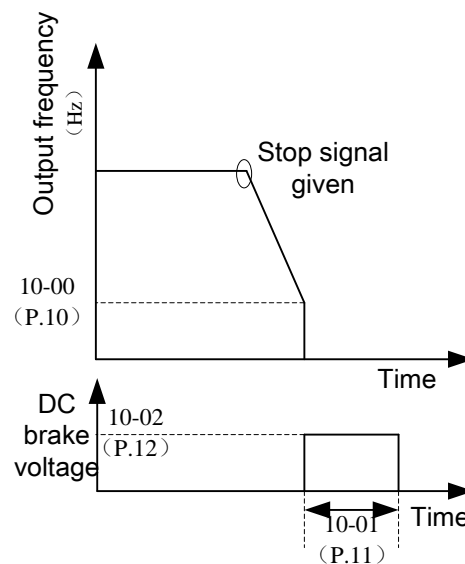

Note: 1. User must set appropriate values to get the best control characteristic.
 2. If any one of 10-00(P.10), 10-01(P.11), 10-02(P.12) is set to “0”, DC brake will not operate, when send stop signal, motor may still rotate due to inertia.

5.10.2 Zero-speed control

➤ Zero-speed function selection

Parameter	Name	Default	Setting Range	Content
10-03 P.151	Zero-speed control function selection	0	0	Off.
			1	DC voltage braking
10-04 P.152	Voltage at zero-speed control	5.0%	0 ~ 30.0%	7.5K/11KF and below model
		2.0%		11K/15KF and above model

Setting Zero-speed control

- ◆ Make sure to set 01-11(P.13) (start frequency) to zero when using this function.

Note: 1. If set 10-04(P. 152) to 6%, output voltage of zero speed is 6% of 01-04(P. 19) (base frequency voltage).
2. This function is only valid under V/F control. Please refer to parameter 00-21 (P.300) for the setting of motor control mode.

5.10.3 DC injection brake before start

- Before starting, motor may be in rotating state due to external force or inertia. If inverter suddenly start operation, the output current may be too large, causing motor damage or trigger inverter protection.

Parameter	Name	Default	Setting Range	Content
10-05 P.242	DC brake before inverter start	0	0	Off
			1	Before starting operate DC brake first.
10-06 P.243	DC brake time before inverter start	0.5s	0 ~ 60.0s	---
10-07 P.244	DC brake voltage before inverter start	4.0%	0 ~ 30.0%	7.5K/11KF and below model
		2.0%		11K/15KF and above model

Setting DC injection brake before start

- ◆ If 10-05(P. 242)=0, DC brake function before start will be off. If 10-05(P. 242)=1, DC brake before start is on, when inverter start, it will inject DC voltage (with 10-07(P. 244) value) into the motor coil to lock the rotor. DC brake will maintain for a period of time (10-06(P. 243) value) before motor starts to run.

See figure below:

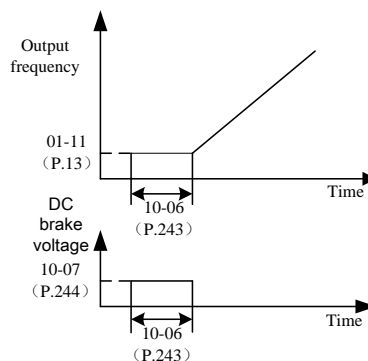

Note: This function is only valid under V/F control, that is, it is valid when 00-21 (P.300)=0.

5.10.4 Restart mode selection

➤ Select suitable start mode according to different load conditions.

Parameter	Name	Default	Setting Range	Content
10-08 P.150	Restart mode selection	0	X0	No frequency search.
			X1	Reserved
			X2	Decrease voltage mode
			0X	Power on once.
			1X	Start each time.
			2X	Only instantaneous stop and restart
			3X	Only valid when the inverter resets in fire mode
10-09 P.57	Restart idling time	99999	0 ~ 30.0s	---
			99999	Off.
10-10 P.58	Restart rising time	5.0s	0 ~ 60.0s	7.5K/11KF and below model
		10.0s		11K/15KF and above model

Setting Restart mode selection

◆ 10-08(P.150) is set by 2 bits. The meaning of each bit is as follows:

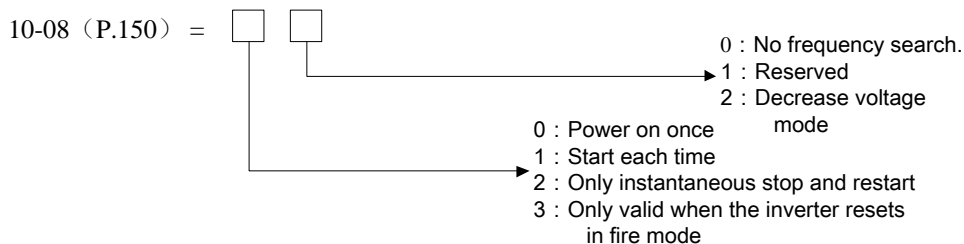

Setting Restart

- ◆ During motor operation, when instantaneous power interruption occur inverter will stop output immediately. If 10-09 (P.57) =99999, inverter will not restart automatically after power is restored; If 10-09(P.57)=0.1~30, when power is restored, inverter will automatically restart the motor after idling for a period of time (10-09(P.57) value).
- ◆ When restarting the motor automatically, output frequency is target frequency, but output voltage is zero and then slowly rises to the proper voltage value. This voltage rise time is called “Restart rising time (10-10(P.58))”.

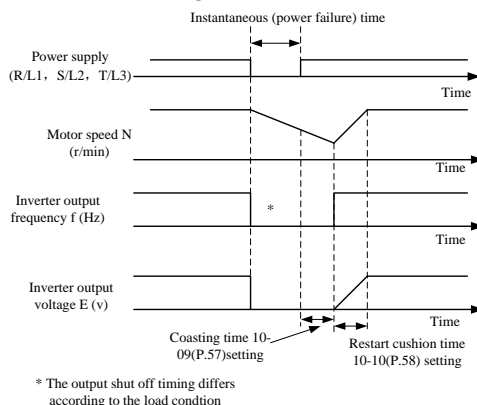

Note:1. 10-08(P.150) must also be set if need instant restart function.
 2. If 10-08(P.150) is not 0, in default inverter do linear acceleration and deceleration.
 3. This function is only valid under V/F control, that is, it is valid when 00-21 (P.300)=0

5.10.5 Remote setting function selection

- If operation box is located away from control cabinet, without analog signal, variable speed can still be realized through digital input.

Parameter	Name	Default	Setting Range	Content
10-11 P.61	Remote control function	0	0	Off
			X1	Remote control function, frequency save in memory
			X2	Remote control function, frequency won't save
			X3	Remote control function, frequency won't save, clear frequency setting every time STF/STR "turn off".
			X4	Remote control function, frequency save in memory every 5s
			1X	Frequency command range 01-01(P.2)~01-00(P.1), frequency command value from RH, RM setting

Setting Remote setting function

- ◆ In external mode, combined mode 1, combined mode 5, use digital input to change output frequency.

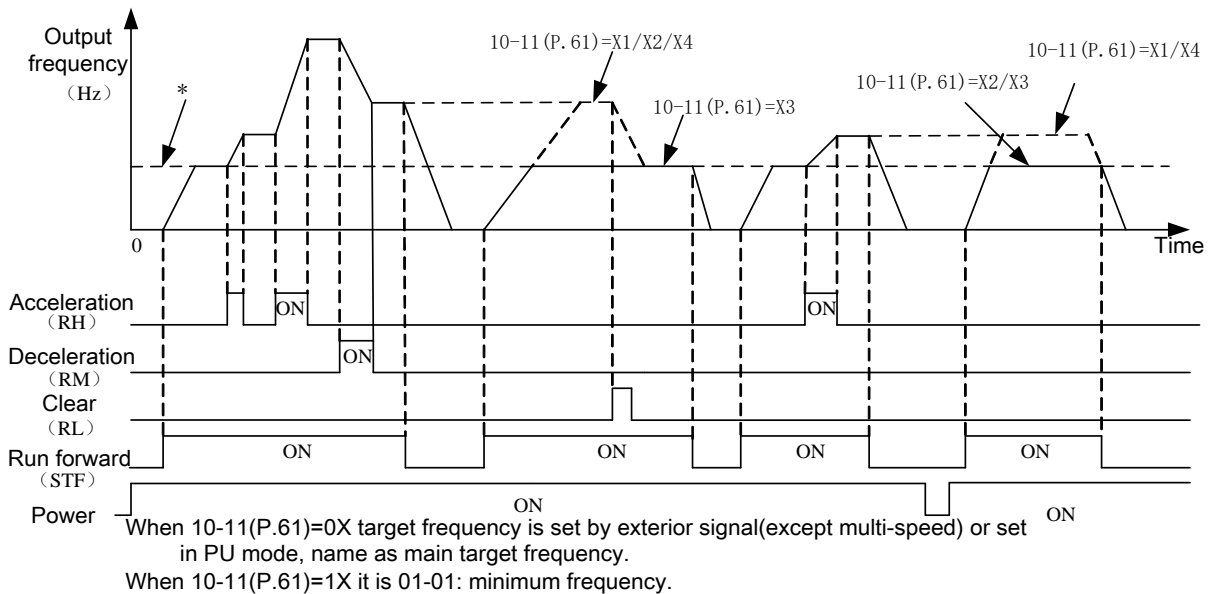

- ◆ Remote function setting

1. 10-11(P.61) decides remote function and ways to save frequency.

Set 10-11(P.61) = X1~X4 (remote control function on), terminal RM, RH, RL will be accelerate (RH), decelerate (RM) and clear (RH). See following figure:

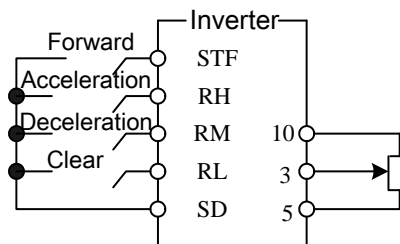

Application parameter group 10

2. If 10-11 (P.61)=1~4, the target frequency of inverter = (frequency set during RH and RM operation + external set frequency other than multi-speed/PU set frequency);

If 10-11 (P.61)=11~14, the target frequency of inverter = frequency set during RH and RM operation.

◆ Frequency save

The frequency save function is to store the remote function frequency (the frequency set by RH, RM operation) in the memory (EEPROM), once the power is turned off then restart, inverter will run to frequency save value (10-11 (P.61) = X1/X4).

< Frequency save memory condition >

10-11(P.61) = X1

1. The frequency when start signal (STF/STR) is "off";
2. When RH (acceleration) and RM (deceleration) are both "off", the remote control setting frequency is stored every 1 minute (If RL is triggered will not write);

10-11(P.61) = X4

1. The frequency when RH (acceleration) and RM (deceleration) signals are both "off";
2. Store the remote control setting frequency once every 5s (If RL is triggered will not write);

Note: 1. When 10-11(P.61) = 0X frequency can be controlled by RH (accelerate) and RM (decelerate) between 0 and (maximum frequency – frequency set by main speed). Output frequency is limited by 01-00(P.1).

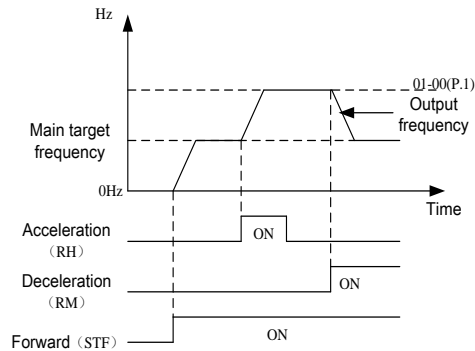

2. When 10-11 (P.61) = 1X, the adjustable frequency range through RH (acceleration) and RM (deceleration) is 01-01(P.2)~01-00(P.1), and output frequency is limit by 01-00 (P.1).

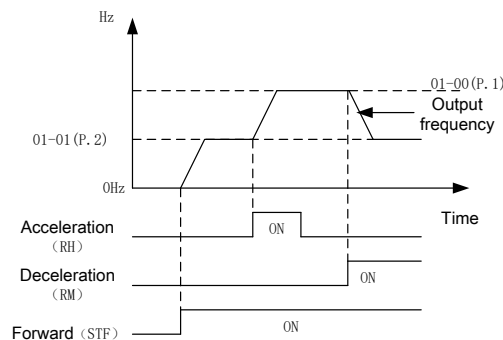

3. When acceleration/deceleration signal "on", acceleration/deceleration time is set by 01-40 (P.219).

4. If start signal (STF/STR) is "off" but RH (accelerate) or RM (decelerate) is "on", target frequency will still change.

5. When the start signal (STF/STR) changes from "on" to "off", if the frequency changes from the RH and RM signals are frequently required, please turn off frequency save function (10-11 (P.61) =X2/X3). If it's turn on (10-11(P.61)=X1/X4), the lifespan of the EEPROM will be shortened due to frequent writing.

6. RH, RM and RL mentioned in this paragraph are the function names of "multi-function digital input terminals". If the terminal assignment is changed, other functions may be affected. Please confirm the functions of each terminal before modifying. For details, please refer to 03-00(P.83), 03-01(P.84), 03-03(P.80), 03-04(P.81).

5.10.6 Auto reset function

➤ This function allows inverter to reset itself and restart when alarm occurs. Choose which alarm to reset.

Parameter	Name	Default	Setting Range	Content
10-12 P.65	Auto reset function	0	0	Off.
			1	When over-voltage, inverter will reset.
			2	When over-current, inverter will reset.
			3	When either over-voltage or over-current, inverter will reset.
			4	When any alarm occurs, inverter will reset.
10-13 P.67	Auto reset times	0	0	Off.
			1 ~ 10	If the alarm exceeds 10-13(P.67) times, inverter will not reset.
10-14 P.68	Auto reset waiting time	6.0s	0 ~ 360.0s	---
10-15 P.69	Auto reset times count	0	Read only	---

Setting Auto reset function

- ◆ After alarm occur, inverter returns to the state before alarm, which is called “auto reset”.
- ◆ The auto reset of inverter is conditional. If alarm occurs and inverter auto reset, but the alarm occurs again within the time (10-14(P.68)*5), then this type of alarm is called “continuous alarm”. If the continuous alarm exceeds a certain number of times, it means that there is a major fault, and this number is called “Auto reset times (10-13) (P.67)”. At this time, inverter will no longer perform auto reset, and need manual troubleshooting by user.
- ◆ If all alarms do not belong to “continuous alarm”, inverter can perform auto reset for an unlimited number of times.
- ◆ The time between the occurrence of alarm and auto reset is called “Auto reset waiting time”.
- ◆ For each auto reset, 10-15(P.69) value will automatically add 1. Therefore, 10-15(P.69) value read from memory represents the number of auto reset.
- ◆ If set parameter 10-15(P.69)=0, auto reset times can be cleared.

Note: The inverter will perform retry only after the retry waiting time of 10-14(P.68). Therefore when using this function, please be aware of the possible danger when operating the inverter.

5.10.7 Forward and reverse rotation dead time

➤ During the process of inverter output forward -reverse transition, set the transition time at 0Hz.

Parameter	Name	Default	Setting Range	Content
10-16 P.119	Forward and reverse rotation dead time	0.0s	0	Off.
			0.1~3000.0s	Waiting and holding time during forward -reverse switch, after inverter output frequency drops to zero.

Setting Dead time of forward-reverse rotation

◆ Dead time of forward -reverse rotation refers to the waiting and holding time of inverter. During this period of time, inverter will transit from the current direction to the reverse direction upon receiving a reverse run command, and its output frequency will drop to zero.

The diagram is as follows:

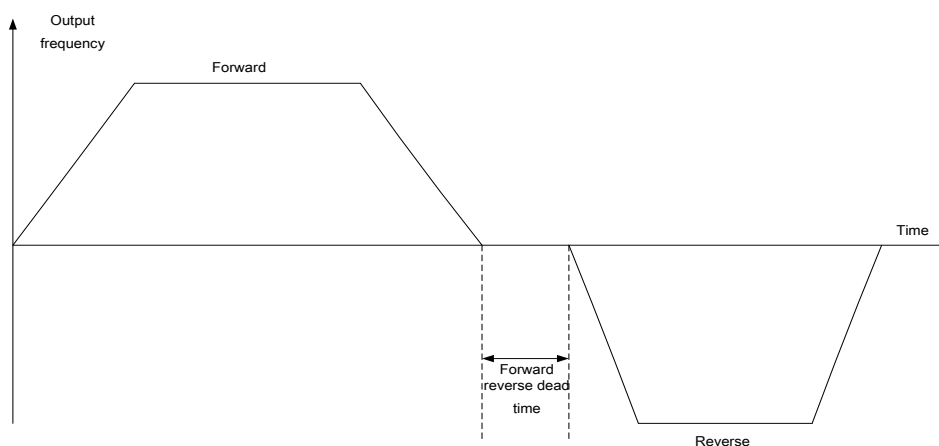

5.10.8 Energy-saving function V/F

➤ In energy-saving mode, in order to minimize inverter output power in constant speed operation, inverter will automatically control the output voltage.

Parameter	Name	Default	Setting Range	Content
10-17 P.159	Energy-saving control function	0	0	Off.
			1	Energy-saving mode.

Setting Energy-saving mode

◆ In energy-saving mode, in order to minimize inverter output power in constant speed operation, inverter will automatically control the output voltage.

Note: 1. This function is only valid under V/F control 00-21(P.300)=0.
 2. If selecting energy-saving operation mode, deceleration time may be longer than the set value. In addition, compared with constant torque load , overvoltage will more likely to occur, please set the deceleration time relatively longer.
 3. For heavy-duty or frequent acceleration/ deceleration applications, energy saving effect may not be very good.

5.10.9 Dwell function V/F

- During acceleration /deceleration, this function can solve the backlash problem caused by stopping acceleration /deceleration, through frequency and time set by this parameters.

Parameter	Name	Default	Setting Range	Content
10-18 P.229	Dwell function selection	0	0	None.
			1	Backlash compensation function.
			2	Stop acceleration and deceleration waiting function.
10-19 P.230	Dwell frequency at acceleration	1.00Hz	0 ~ 650.00Hz	Set the stopping frequency and time of Dwell function during acceleration.
10-20 P.231	Dwell time at acceleration	0.5s	0 ~ 360.0s	
10-21 P.232	Dwell frequency at deceleration	1.00Hz	0 ~ 650.00Hz	Set the stopping frequency and time of Dwell function during deceleration.
10-22 P.233	Dwell time at deceleration	0.5s	0 ~ 360.0s	

Setting Dwell function

◆ Backlash compensation (10-18(P.229)=1)

The gears of the reducer have biting backlash, and there is an empty section between forward and reverse rotation. This unloaded segment is called backlash, and even if the motor rotates, it will not produce a mechanical following state.

Specifically, when switching the direction of rotation and changing from constant speed operation to deceleration operation, the motor shaft generates excessive torque, and the motor current rapidly increases or becomes a regenerative state.

To avoid backlash, the acceleration and deceleration are temporarily interrupted during acceleration and deceleration. The frequency and time of interrupting acceleration and deceleration are set by 10-18 (P.229) ~ 10-22 (P.233).

As shown in the following diagram:

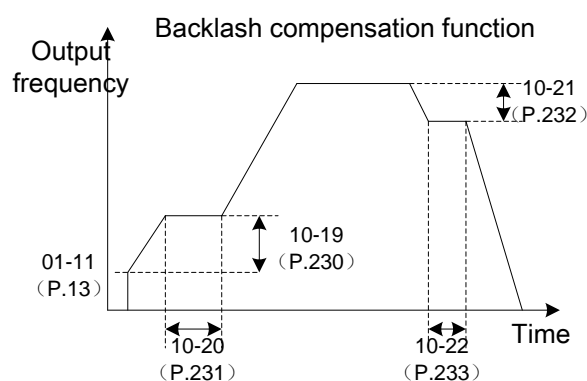

Note: After setting backlash compensation, only the interruption time in acceleration and deceleration time will become longer.

◆ Acceleration and deceleration interrupt waiting function (10-18(P.229)=2)

When 10-18 (P.229) = 2, enable acceleration and deceleration interrupt waiting function. When accelerating to the frequency set in 10-19 (P.230), wait for the time set in 10-20 (P.231) before accelerating to the target; when decelerating to the frequency set in 10-21 (P.232), wait for the time set in 10-22 (P.233) before decelerating to the target.

As shown in the following diagram:

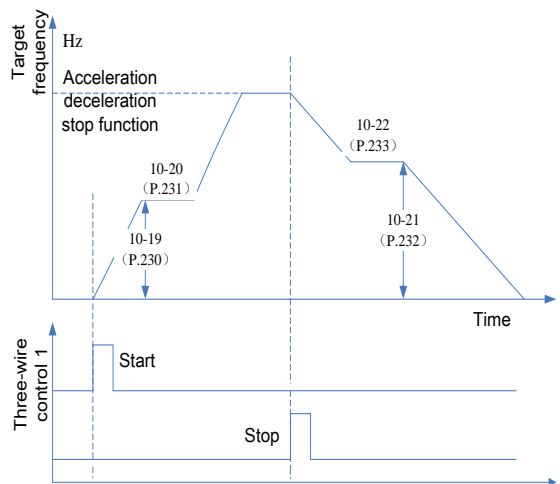

Note: After setting backlash compensation, only the interruption time in acceleration and deceleration time will become longer.

5.10.10 Triangular wave function V/F

➤ According to a certain period, through triangular wave makes output frequency oscillate.

Parameter	Name	Default	Setting Range	Content
10-23 P.234	Triangular wave function selection	0	0	Off
			1	If terminal function TRI is triggered, triangular wave function will on.
			2	Triangular wave function is on at all time.
10-24 P.235	Maximum amplitude	10.0%	0 ~ 25.0%	---
10-25 P.236	Amplitude compensation for deceleration	10.0%	0 ~ 50.0%	---
10-26 P.237	Amplitude compensation for acceleration	10.0%	0 ~ 50.0%	---
10-27 P.238	Amplitude acceleration time	10.00s	0 ~ 360.00s/ 0 ~ 3600.0s	When 01-08(P.21)=0, the unit of 10-27(P.238) and 10-28(P.239) is 0.01s.
10-28 P.239	Amplitude deceleration time	10.00s	0 ~ 360.00s/ 0 ~ 3600.0s	When 01-08(P.21)=1, the unit of 10-27(P.238) and 10-28(P.239) is 0.1s.

Setting

Triangular wave function

- ◆ If 10-23(P.234) set to 1, triangular wave function will be on when terminal function TRI is triggered. Please set one of 03-00(P.83)~03-01(P.84), 03-03(P.80)~03-04(P.81) to “36”, and then give TRI signals to the digital input terminal.
- ◆ If 10-23(P.234) set to 2, triangular wave function will be on all the time.

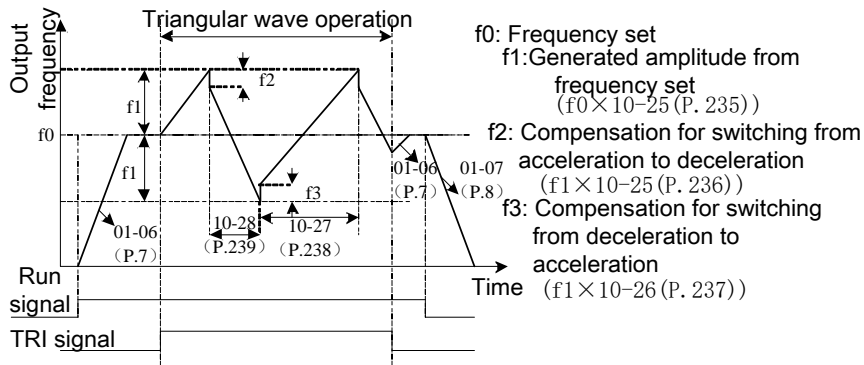

Note: 1. Output frequency is limited by the upper and lower frequency limits in triangular wave operation.
 2. If the values of amplitude compensation 10-25(P.236) and 10-26(P.237), are too large, overvoltage trip and stall prevention protection will trigger.
 3. This function is only valid under V/F control 00-21(P.300)=0.

5.10.11 Voltage stall action level

- This parameter is used to set the voltage stall action discrimination level.

Parameter	Name	Default	Setting Range	Content
10-46 P.268	Voltage stall level	380V	155 ~ 410V	220V model
		760V	310 ~ 820V	440V model

Setting

Voltage stall action level

- ◆ When the inverter's DC bus voltage is higher than the setting of 10-46 (P.268), the inverter is in voltage stall state.

5.10.12 Reciprocating machine function

- Special functions for reciprocating machine according to customer needs.

Parameter	Name	Default	Setting Range	Content
10-55 P.226	Reciprocating machine function selection	0	0	Off
			1	Turn on reciprocating machine function
10-56 P.227	Reciprocating forward limit time	0.0s	0 ~ 3600.0s	Run forward for more than 10-56 (P.227) time, inverter will decelerate to stop. When set to 0, this function is invalid.
10-57 P.228	Reciprocating reverse limit time	0.0s	0 ~ 3600.0s	Run reverse for more than 10-57(P.228) time, inverter will decelerate to stop. When set to 0, this function is invalid.

Setting

Reciprocating machine function

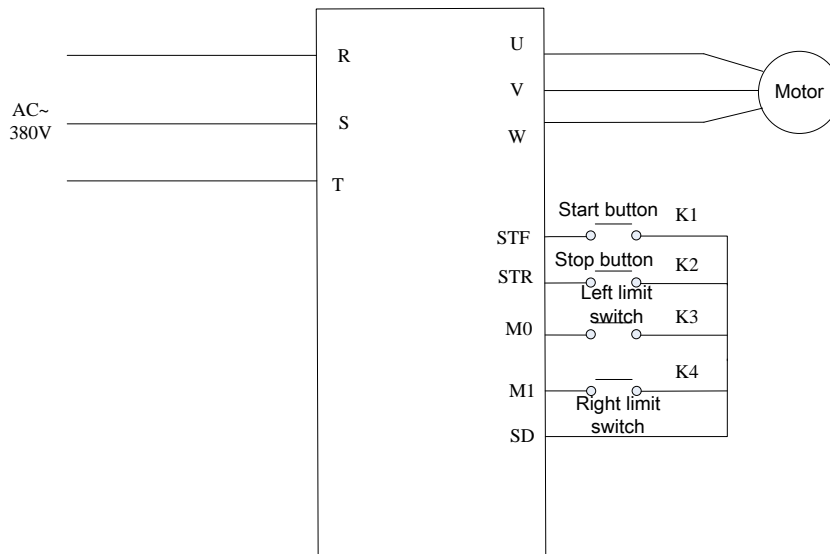

System wiring diagram

- ◆ Please wire according to the above diagram, connect a limit switch between M0 and SD, M1 and SD, and connect a pulse switch between STF and SD, STR and SD.
- ◆ Power on the inverter, execute parameter 00-02=3 (P.998=1), set parameter 10-55 (P.226) to 1, turn on reciprocating machine function. The multi-function terminal settings are all factory settings no need to change value. If target frequency is given by external terminal, the M0 and M1 terminals will affect the target frequency, so please set the value of 04-01 (P.5) and 04-02 (P.6) to the same as target frequency.
- ◆ When K3 and K4 are both in off state, press K1 and inverter forward turn to trigger K3 once, then inverter reverse turn to trigger K4 once and then turn forward, reciprocating. If press K2 the system stops running.
- ◆ When K3 (or K4) is in off state, press K1 and it will reverse (or forward) until trigger K4 (or K3) once and then forward (or reverse). If press K2 the system stops running.
- ◆ To prevent dangerous situations caused by the failure of the limit switch, additional one-way running time: reciprocating forward/reverse limit time is added. Two limit switches are not allowed to be closed at the same time. If they are closed at the same time, the system will stop running.

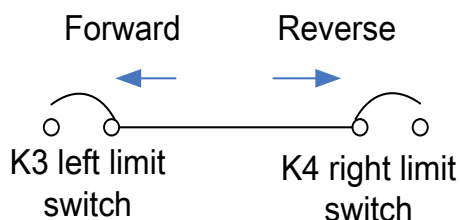

Operation diagram

5.11 Advanced parameter group 11

Group	Parameter Number	Name	Setting Range	Default	Page
11-00	P.320	Slip compensation gain	0~200%	85%	155
11-01	P.321	Torque boost filter coefficient	0 ~ 2000	20	155
11-02	P.322	Cutoff frequency point of current filter time 1	0~30.00Hz	4.00Hz	155
11-03	P.323	Current filter time 1	0~400.00ms	According to kw	155
11-04	P.324	Low frequency current filter time 2	0~400.00ms	According to kw	155
11-05	P.325	High frequency current filter time 2	0~400.00ms	According to kw	155

5.11.1 Slip compensation gain

- Set the gain coefficient during slip compensation. The larger the set value, the greater the slip compensation.

Parameter	Name	Default	Setting Range	Content
11-00 P.320	Slip compensation gain	85%	0~200%	---

5.11.2 Torque boost filter

- Set the filter coefficient during torque boost. The larger the set value, the larger the filter.

Parameter	Name	Default	Setting Range	Content
11-01 P.321	Torque boost filter coefficient	20	0~2000	---

5.11.3 Current filter

- Set the filter coefficient of the current. The larger the set value, the larger the filter.

Parameter	Name	Default	Setting Range	Content
11-02 P.322	Cutoff frequency point of current filter time 1	4.00Hz	0~30.00Hz	---
11-03 P.323	Current filter time 1	According to kw	0~400.00ms	---
11-04 P.324	Low frequency current filter time 2	According to kw	0~400.00ms	---
11-05 P.325	High frequency current filter time 2	According to kw	0~400.00ms	---

5.12 Special Adjustment Parameter Group 13

Group	Parameter Number	Name	Setting Range	Default	Page
13-00	P.89	Slip compensation coefficient	0 ~ 10	0	156
13-03	P.286	High frequency vibration suppression factor	0.2K~5.5K model : 0 ~ 1515	300	156
			7.5K/11KF and above : 0 ~ 1515	509	

5.12.1 Slip Compensation V/F

- This parameter can set the compensation frequency so that the motor running speed at the rated current can be closer to the set speed, thereby improving the accuracy of speed control.

Parameter	Name	Default	Setting Range	Content
13-00 P.89	Slip compensation coefficient	0	0 ~ 10	Execute slip compensation with target frequency as standard. The quantity of compensation set to 10 is 3% of target frequency.

Note: 1. This function is only valid under V/F control 00-21(P.300)=0.

2. At the process of slip compensation, the output frequency may be larger than the set frequency.

5.12.2 Vibration inhibition

- It is used to suppress the large fluctuation of inverter output current, large fluctuation of motor speed and motor vibration.

Parameter	Name	Default	Setting Range	Content
13-03 P.286	High frequency vibration inhibition factor	300	0 ~ 1515	0.2K~5.5K model If the motor vibrates at a higher frequency, adjust the set value of 13-03(P.286). It is recommended to gradually increase the set value based on the increment of 1.
		509		7.5K/11KF and above

Setting Vibration inhibition factor

- ◆ In practical applications, the frequency range where the vibration occurs is usually lower than or higher than half of the rated frequency of the motor to distinguish as "low frequency vibration " or "high frequency vibration ", that is:
 If the rated frequency of the motor nameplate is 50Hz,
 If the frequency of oscillation is lower than 25Hz, it is considered as "low frequency vibration".
 If the frequency of oscillation is higher than 25Hz, it is considered to be "high frequency vibration ".

Note: The motor current will fluctuate in a certain operating frequency band under Normal duty conditions, which may cause slight vibration of the motor. If it does not cause application impact, it can be ignored.

5.13 User registered parameter 15

Group	Parameter Number	Name	Setting Range	Default	Page
15-00	P.900	User registered parameter 1	P parameter mode: 0~399 Parameter group mode: 00-00~13-99	99999	158
15-01	P.901	User registered parameter 2		99999	158
15-02	P.902	User registered parameter 3		99999	158
15-03	P.903	User registered parameter 4		99999	158
15-04	P.904	User registered parameter 5		99999	158
15-05	P.905	User registered parameter 6		99999	158
15-06	P.906	User registered parameter 7		99999	158
15-07	P.907	User registered parameter 8		99999	158
15-08	P.908	User registered parameter 9		99999	158
15-09	P.909	User registered parameter 10		99999	158
15-10	P.910	User registered parameter 11		99999	158
15-11	P.911	User registered parameter 12		99999	158
15-12	P.912	User registered parameter 13		99999	158
15-13	P.913	User registered parameter 14		99999	158
15-14	P.914	User registered parameter 15		99999	158
15-15	P.915	User registered parameter 16		99999	158
15-16	P.916	User registered parameter 17		99999	158
15-17	P.917	User registered parameter 18		99999	158
15-18	P.918	User registered parameter 19		99999	158
15-19	P.919	User registered parameter 20		99999	158

5.13.1 User registered parameter

- The user parameter group is used to register the number of the parameter that does not require the user to restore the factory default value.

Parameter	Name	Default	Setting Range	Content
15-00 P.900	User registered parameter 1	99999	P mode: 0 ~ 399 Parameter group mode: 00-00~13-99	---
15-01 P.901	User registered parameter 2	99999		---
15-02 P.902	User registered parameter 3	99999		---
15-03 P.903	User registered parameter 4	99999		---
15-04 P.904	User registered parameter 5	99999		---
15-05 P.905	User registered parameter 6	99999		---
15-06 P.906	User registered parameter 7	99999		---
15-07 P.907	User registered parameter 8	99999		---
15-08 P.908	User registered parameter 9	99999		---
15-09 P.909	User registered parameter 10	99999		---
15-10 P.910	User registered parameter 11	99999		---
15-11 P.911	User registered parameter 12	99999		---
15-12 P.912	User registered parameter 13	99999		---
15-13 P.913	User registered parameter 14	99999		---
15-14 P.914	User registered parameter 15	99999		---
15-15 P.915	User registered parameter 16	99999		---
15-16 P.916	User registered parameter 17	99999		---
15-17 P.917	User registered parameter 18	99999		---
15-18 P.918	User registered parameter 19	99999		---
15-19 P.919	User registered parameter 20	99999		---

Setting

User registered parameter

- ◆ The parameter values set in this parameter group will not be restored to the factory default value when performing 00-02=5/6 (P.999=2/3)
- ◆ The parameter value set in this parameter group is the parameter number required to be registered by the user. The parameter values of the registered parameter number will not be restored to the factory default value when performing 00-02=5/6 (P.999=2/3)
- ◆ Please refer to 5.1.2 parameter management section for the setting of restoring the factory default value.

6. INSPECTION AND MAINTENANCE

6.1 Inspection item

6.1.1 Daily inspection item

- Inverter is mainly composed of semiconductor components. In order to prevent faults caused by influence of environment such as temperature, humidity, dust and vibration, or aging and service life of used parts, users must do daily inspections
 1. Whether the surrounding environment for installation is normal (temperature, humidity, dust density around inverter).
 2. Whether the power supply voltage is normal (whether the three-phase voltage between terminals R/L1, S/L2 and T/L3 is normal).
 3. Whether the wirings are firm (whether the external wirings of the main circuit terminal and the control board terminal are firm).
 4. Whether the cooling system is normal (whether there is abnormal sound at the fan operation and whether the connecting wire is firm).
 5. Whether the indicator light is normal (such as LED indicator on control board, LED indicator on keypad and LED on keypad screen).
 6. Whether the motor is running as expected.
 7. Whether there is abnormal vibration, sound or smell at the motor operation.
 - 8 Whether there is liquid leakage in the filter capacitor on the capacitor board.

Caution

Pay attention to safety during inspection!

6.1.2 Regular inspection items

- Check the places that can be inspected only when the operation is stopped and require regular inspections of specific places.
 1. Check whether the connectors and connecting wires are normal (check whether the connectors and connecting wires between the main circuit board and the control board are firm or is damaged).
 2. Check whether the components on the main circuit board and control board are overheated.
 3. Check whether the electrolytic capacitors on the main circuit board and control board are leaking.
 4. Check the IGBT module on the main circuit board.
 5. Make sure to clean the dust and foreign objects on the circuit board.
 6. Check the insulation resistance.
 7. Whether the cooling system is abnormal (whether the fan cable is secure, please clean the air filter/air duct).
 8. Check whether the fixing device is firm, and tighten the fixing screw.
 9. Check whether the external wires and terminal block are damaged.

Caution

Pay attention to safety during inspection!

6.1.3 Ways to measure voltage, current, power on main circuit

- When testing, please first remove the external wiring of the main circuit terminals (R/L1, S/L2, T/L3, U/T1, V/T2, W/T3), and measure by resistance mode of the meter.

	Positive	Negative	Normal situation		Positive	Negative	Normal situation
Terminal	R/L1	+/P	Closed	Terminal	U/T1	+/P	Closed
	S/L2	+/P	Closed		V/T2	+/P	Closed
	T/L3	+/P	Closed		W/T3	+/P	Closed
	+/P	R/L1	Open		+/P	U/T1	Open
	+/P	S/L2	Open		+/P	V/T2	Open
	+/P	T/L3	Open		+/P	W/T3	Open
	R/L1	-/N	Open		U/T1	-/N	Open
	S/L2	-/N	Open		V/T2	-/N	Open
	T/L3	-/N	Open		W/T3	-/N	Open
	-/N	R/L1	Closed		-/N	U/T1	Closed
	-/N	S/L2	Closed		-/N	V/T2	Closed
	-/N	T/L3	Closed		-/N	W/T3	Closed

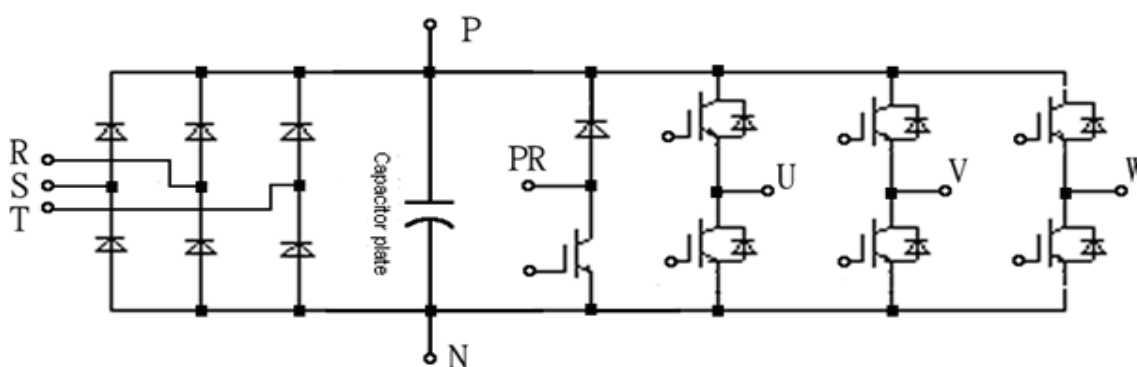

Note: The above figure uses frame B as an example.

6.1.4 Cleaning

- Always keep the inverter running in a clean state.
- ◆ Use a soft brush to remove dust and debris from fan blades, fan covers, and heat sink to keep the inverter in good heat dissipation.
- ◆ After immersing a soft cloth in neutral detergent, gently wipe off the dirty part of the case.

Note: 1. Do not use solvents to wipe the case, such as acetone, benzene, toluene and alcohol. They will cause the surface paint of the inverter to peel off.
 2. The display part of the keypad (PU301/DU06/DU08, etc.) is weak against detergent or alcohol. Do not use such chemicals when wiping.

6.1.5 Replacement parts

- Inverter is composed of many electronic components such as semiconductor components.
- Due to the composition or physical characteristics, the following components will age within a certain period of time, thus reducing the inverter performance and even causing faults. Therefore, it is necessary to replace them on a regular basis.
- Use lifetime detection function as a guidance of parts replacement.

Part name	Estimated lifespan	Description
Cooling fan	2 years	For the axle of a fan, the standard lifetime is about 10 – 35 thousand hours. If fan operates 24 hours per day, should be replaced every 2 years.
Capacitor	5 years	Capacitor is an electrolytic capacitor that deteriorates with time. The deterioration level depends on ambient conditions. Generally, it should be replaced every 5 years.
Relay	---	If bad contact occurs, please replace it immediately.

Note: 1. Please send the inverters to the factory for replacement.
 2. For the replacement of cooling fan, please refer to section 3.8 Fan Replacement.

6.2 Ways to measure voltage, current, power on main circuit

6.2.1 Selecting measurement instruments

- Since inverter voltage and current on input side and output side includes harmonics, measurement data result may vary. Choose the instruments below (with commercial power supply) for measurement.

	Voltage (V)	Current (A)	Power (kW)
Input side (R/L1, S/L2, T/L3)	Moving-iron type	Moving-iron type	Electrodynamic type
Output side (U/T1, V/T2, W/T3)	Rectifier type	Moving-iron type	Electrodynamic type

Note: 1. Please pay attention to the instrument range and polarity;
2. Please pay attention to personal and property safety.

6.2.2 Measurement of voltage

- Inverter input side
Input side voltage has a sine wave and with extremely small distortion, accurate measurement can be made with an ordinary AC meter.
- Inverter output side
Since the output side voltage has a PWM-controlled rectangular wave, always use a rectifier type voltmeter. A pointer type meter cannot be used to measure the output side voltage as it indicates a value much greater than the actual value.
A moving-iron type meter indicates an effective value which includes harmonics and therefore the value is larger than that of the fundamental wave.
The value monitored on keypad is the inverter-controlled voltage itself. Hence, that value is accurate and it is recommended to monitor values using keypad.

6.2.3 Measurement of current

- Use moving-iron type meters on both the input and output sides of inverter. However, if the carrier frequency exceeds 5kHz, do not use this type of meter since an overcurrent losses produced in the internal metal parts of the meter will increase and may burn. In this case, use an approximate-effective value type.
- Since current on the inverter input side tends to be imbalanced, measure three phases together is recommended. Correct value cannot be obtained by measuring only one or two phases. On the other hand, the unbalanced ratio of each phase of the output side current should be within 10%.
- When a clamp ammeter is used, always use an effective value detection type. A mean value detection type produces a large error and may indicate an extremely smaller value than the actual value. The value monitored on keypad is accurate if the output frequency varies, and it is recommended to monitor values (provide analog output) using the keypad.

6.2.4 Measurement of power

- Use digital power meters at the input and output terminals of inverter simultaneously, or use electrodynamic meters at the input and output terminals of inverter simultaneously. Then, measure the power by the 2-power measurement method or the 3-power measurement method. However, the input terminal current tends to be imbalanced, so it is recommended to use 3-power measurement method for measurement.

6.2.5 Measurement of insulation resistance

➤ Inverter insulation resistance

1. Before measuring the inverter insulation resistance, first dismount the wiring of all the main-circuit terminals and control board. Then do the wiring as shown in the right picture
2. The measurement is only suitable for the main circuit. It is prohibited to use a high-resistance meter for measuring terminals on the control board.
3. The value of the insulation resistance shall be greater than $5M\Omega$.

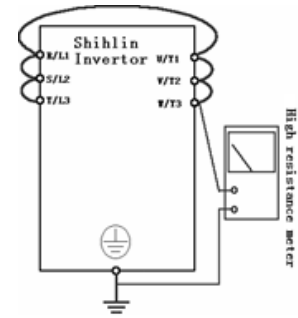

Note: Please use a 500 VDC megger.

➤ Motor insulation resistance

1. Before the measurement, please dismount the motor, and execute the wiring as shown in the diagram on the right.
2. The value of the insulation resistance shall be greater than $5M\Omega$

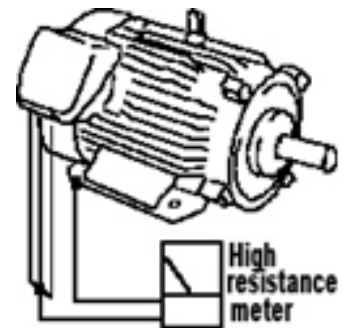

Note: Please use a suitable megger.

6.2.6 Hi-pot test

- Do not conduct a hi-pot test. Deterioration may occur on the internal semiconductor components of the inverter.

7. Appendix

7.1 Appendix 1 Parameter table

7.1.1 Parameter in P sequence

Parameter Number	Group	Name	Setting Range	Default	Page
P.0	01-10	Torque boost	0.75K and under :0 ~ 30.0%	6.0%	68
			1.5K~3.7K model : 0 ~ 30.0%	4.0%	
			5.5K~7.5K/11KF model : 0 ~ 30.0%	3.0%	
			11K/15KF and above model : 0 ~ 30.0%	2.0%	
P.1	01-00	Maximum frequency	0.00 ~ 01-02 (P.18) Hz	120.00Hz	64
P.2	01-01	Minimum frequency	0 ~ 120.00Hz	0.00Hz	64
P.3	01-03	Base frequency	50Hz system setting: 0 ~ 650.00Hz	50.00Hz	65
			60Hz system setting: 0 ~ 650.00Hz	60.00Hz	
P.4	04-00	Speed 1 (high speed)	0 ~ 650.00Hz	60.00Hz	100
P.5	04-01	Speed 2 (medium speed)	0 ~ 650.00Hz	30.00Hz	100
P.6	04-02	Speed 3 (low speed)	0 ~ 650.00Hz	10.00Hz	100
P.7	01-06	Acceleration time	3.7K and below : 0 ~ 360.00s/0 ~ 3600.0s	5.00s	66
			5.5K model : 0 ~ 360.00s/0 ~ 3600.0s	10.00s	
			7.5K/11KF and above model : 0 ~ 360.00s/0 ~ 3600.0s	20.00s	
P.8	01-07	Acceleration time	3.7K and below : 0 ~ 360.00s/0 ~ 3600.0s	5.00s	66
			5.5K ~7.5K/11KF model : 0 ~ 360.00s/0 ~ 3600.0s	10.00s	
			11K/15KF and above model : 0 ~ 360.00s/0 ~ 3600.0s	30.00s	
P.9	06-00	Electronic thermal relay capacity	0~500.00A	0.00A	110
P.10	10-00	DC brake operating frequency	0 ~ 120.00Hz	3.00Hz	144
P.11	10-01	DC brake operating time	0 ~ 60.0s	0.5s	144
P.12	10-02	DC brake operating voltage	7.5K/11KF and below model : 0 ~ 30.0%	4.0%	144
			11K/15KF and above model : 0 ~ 30.0%	2.0%	
P.13	01-11	Starting frequency	0 ~ 60.00Hz	0.50Hz	68
P.14	01-12	Load pattern selection	0: For constant torque loads (conveyor belt, etc.)	0	69
			1: For variable torque loads (fans and pumps, etc.)		
			2 ~ 3 : For Lifting loads		
			4: Multipoint V/F curve		
			5~13: Special two-point V/F curve		
P.15	01-13	JOG frequency	0 ~ 650.00Hz	5.00Hz	71
P.16	01-14	JOG Acc/ Dec time	0 ~ 360.00s/0 ~ 3600.0s	0.50s	71
P.17	02-20	Terminal 3-5 signal range selection	0: Signal sampling range from 4~20mA.	1	80
			1: Signal sampling range from 0 ~ 10V.		
			2: Signal sampling range from 0 ~ 5V.		
P.18	01-02	High-speed maximum frequency	01-00 (P.1) ~ 650.00Hz	120.00Hz	64

Appendix 1 Parameter table

Parameter Number	Group	Name	Setting Range	Default	Page
P.19	01-04	Base voltage	0 ~ 1000.0V	99999	65
			99999 : Change according to the input voltage		
P.20	01-09	Acceleration/deceleration reference frequency	50Hz system setting: 1.00 ~ 650.00Hz	50.00Hz	66
			60Hz system setting: 1.00 ~ 650.00Hz	60.00Hz	
P.21	01-08	Acceleration/deceleration time increments	0: Time increment is 0.01s	0	66
			1: Time increment is 0.1s		
P.22	06-01	Stall prevention operation level	0 ~ 250.0%	150.0%	111
P.23	06-02	Stall prevention operation level correction factor	0 ~ 200.0%	99999	111
			99999: Stall prevention operation level is the setting value of 06-01(P.22).		
P.24	04-03	Speed 4	0 ~ 650.00Hz	99999	100
			99999: Off		
P.25	04-04	Speed 5	Same as 04-03	99999	100
P.26	04-05	Speed 6	Same as 04-03	99999	100
P.27	04-06	Speed 7	Same as 04-03	99999	100
P.28	01-15	Output frequency filter time	0 ~ 31	0	72
P.29	01-05	Acceleration/deceleration curve selection	0: Linear acceleration /deceleration curve	0	66
			1: S shape acceleration /deceleration curve 1		
			2: S shape acceleration /deceleration curve 2		
			3: S shape acceleration /deceleration curve 3		
P.30	06-05	Regenerative brake selection	0: Brake duty is fixed at 3%, parameter 06-06(P.70) will be off.	0	112
			1: Brake duty is 06-06(P.70) value.		
P.31	00-12	Soft-PWM carrier function selection	0: Off	0	57
			1: When 00-11(P.72)<5,Soft-PWM is on(only apply to V/F control)		
			2 : When 00-11(P.72) > 9, if the IGBT temperature is higher than 60°C, carrier frequency will decrease automatically, when temperature go back to under 40°C, carrier frequency go back to 00-11(P.72) value.		
P.32	07-02	Serial communication baud rate	0 : baud rate :4800bps	1	120
			1 : baud rate :9600bps		
			2 : baud rate :19200bps		
			3 : baud rate :38400bps		
			4 : baud rate :57600bps		
			5 : baud rate :115200bps		
P.33	07-00	Communication protocol selection	0 : Modbus protocol	1	120
			1 : Shihlin protocol		
P.34	07-11	Communication EEPROM write-in selection	0 :When writing parameters through communication, write in RAM and EEPROM	0	135
			1 :When writing parameters through communication, only write into RAM		

Parameter Number	Group	Name	Setting Range	Default	Page
P.35	00-19	Communication mode selection	0: In communication mode, run signal and frequency is given by communication.	0	59
			1: In communication mode, run signal and frequency is given by external signal.		
P.36	07-01	Inverter communication station number	0 ~ 254	0	120
P.37	00-08	Speed display	0 : Display output frequency(not mechanical speed)	0.0	55
			0.1~5000.0		
			1~50000		
P.39	02-21	Terminal 3-5 maximum operation frequency	50Hz system:1.00 ~ 650.00Hz	50.00Hz	80
			60Hz system:1.00 ~ 650.00Hz	60.00Hz	
P.41	03-20	Output frequency detection sensitivity	0 ~ 100.0%	10.0%	95
P.42	03-21	Output frequency detection for forward rotation	0 ~ 650.00Hz	6.00Hz	95
P.43	03-22	Output frequency detection for reverse rotation	0 ~ 650.00Hz	99999	95
			99999: Same as the setting of 03-21(P.42)		
P.44	01-22	Second acceleration time	0 ~ 360.00s/0 ~ 3600.0s	99999	74
			99999 : Off		
P.45	01-23	Second deceleration time	0 ~ 360.00s/0 ~ 3600.0s	99999	74
			99999 : Off		
P.46	01-24	Second torque boost	0 ~ 30.0%	99999	74
			99999 : Off		
P.47	01-25	Second base frequency	0 ~ 650.00Hz	99999	74
			99999 : Off		
P.48	07-03	Data length	0 : 8bit	0	120
			1 : 7bit		
P.49	07-04	Stop bit length	0 : 1bit	0	120
			1 : 2bit		
P.50	07-05	Parity check selection	0 : No parity check	0	120
			1 : Odd		
			2 : Even		
P.51	07-06	CR/LF selection	1: CR only	1	120
			2 : Both CR and LF		
P.52	07-08	Number of communication retries	0 ~ 1000	5	120
P.53	07-09	Communication interval allowed time	0 ~ 999.8s : Check communication timeout with the set value	99999	120
			99999 : No timeout check		
P.56	02-52	Inverter rated current display level	0~500.00A	According to model	85
P.57	10-09	Restart idling time	0 ~ 30.0s	99999	146
			99999: Off.		
P.58	10-10	Restart rising time	7.5K/11KF and below model : 0 ~ 60.0s	5.0s	146
			11K/15KF and above model : 0 ~ 60.0s	10.0s	

Appendix 1 Parameter table

Parameter Number	Group	Name	Setting Range	Default	Page
P.59	00-10	Built-in keypad set target frequency selection	XXX0: Use wheel on built-in keypad or external keypad to set frequency	0	59
			XXX1: Use keypad knob on external keypad to set frequency		
			X0XX: Frequency change done and setting saves in 30 seconds		
			X1XX: Frequency change done and setting saves in 10 seconds		
			X2XX: Every frequency change will not save		
			0XXX: Set frequency will work immediately when use wheel on built-in keypad		
			1XXX: Set frequency will work after pressing SET when use wheel on built-in keypad		
P.60	02-10	Terminal 3-5 filter time	0 ~ 2000ms	31	80
P.61	10-11	Remote control function	0: Off	0	147
			X1 : Remote control function, frequency save in memory		
			X2 : Remote control function, frequency won't save		
			X3 : Remote control function, frequency won't save, clear frequency setting every time STF/STR "turn off".		
			X4: Remote control function, frequency save in memory every 5s		
			1X:Frequency command range 01-01(P.2)~01-00 (P.1), frequency command value from RH,RM setting		
P.62	03-23	Zero current detection level	0 ~ 200.0%	5.0%	96
			99999: Off		
P.63	03-24	Zero current detection time	0.05 ~ 100.00s	0.50s	96
			99999: Off		
P.65	10-12	Auto reset function	0: Off.	0	149
			1: When over-voltage, inverter will reset.		
			2: When over-current, inverter will reset.		
			3: When either over-voltage or over-current, inverter will reset.		
			4: When any alarm occurs, inverter will reset.		
P.66	06-03	Stall prevention operation reduction starting frequency	50Hz system:0 ~ 650.00Hz	50.00Hz	111
			60Hz system:0 ~ 650.00Hz	60.00Hz	
P.67	10-13	Auto reset times	0: Off.	0	149
			1 ~ 10: If the alarm exceeds 10-13(P.67) times, inverter will not reset.		
P.68	10-14	Auto reset waiting time	0 ~ 360.0s	6.0s	149
P.69	10-15	Auto reset times count	Read only	0	149

Parameter Number	Group	Name	Setting Range	Default	Page
P.70	06-06	Special regenerative brake duty	0 ~ 100.0%	0.0%	112
P.71	00-13	Idling brake / DC brake	0: Idling brake 1: DC brake	1	58
P.72	00-11	Carrier frequency	11K/15KF and below model : 1~15kHz 15K/18.5KF and above Heavy Duty : 1~15kHz 15K/18.5KF and above Normal Duty : 1~10kHz	5kHz	57
P.75	00-14	Stop function selection	0: Press STOP button and inverter stop running in PU and H2 mode 1: Press STOP button and inverter stop running in all mode.	1	58
P.77	00-03	Selection of parameters write protection	0: Parameters can be written only when the motor stops. 1: Parameters cannot be written. 2: Parameters can also be written when the motor is running. 3: Parameters cannot be read when in password protection.	0	52
P.78	00-15	Prevent forward/reverse rotation selection	0: Forward/reverse rotation are both permitted. 1: Prevent reverse rotation (Giving reverse signal decelerates and stops the motor). 2: Prevent forward rotation (Giving forward signal decelerates and stops the motor).	0	59
P.79	00-16	Operation mode selection	0: "PU mode", "external mode" and "Jog mode" are interchangeable. 1: "PU mode" and "JOG mode" are interchangeable. 2: "External mode" only 3: "Communication mode" only 4: "Combined mode 1" 5: "Combined mode 2" 6: "Combined mode 3" 7: "Combined mode 4" 8: "Combined mode 5"	0	59
P.80	03-03	Terminal M0 input function	Same as 03-00	2	90
P.81	03-04	Terminal M1 input function	Same as 03-00	3	90
P.83	03-00	Terminal STF input function	0: STF(Inverter runs forward) 1: STR(Inverter runs reverse) 2: RL(Multi-speed low speed) 3: RM(Multi-speed medium speed) 4: RH(Multi-speed high speed) 5: Reserved 6: External thermal relay actuate 7: MRS(Stops inverter output immediately) 8: RT(Inverter second function) 9: EXJ(External JOG)	0	90

Appendix 1 Parameter table

Parameter Number	Group	Name	Setting Range	Default	Page
P.83	03-00	Terminal STF input function	10 : STF+EXJ	0	90
			11 : STR+EXJ		
			12 : STF+RT		
			13 : STR+RT		
			14 : STF+RL		
			15 : STR+RL		
			16 : STF+RM		
			17 : STR+RM		
			18 : STF+RH		
			19 : STR+RH		
			20 : STF+RL+RM		
			21 : STR+RL+RM		
			22 : STF+RT+RL		
			23 : STR+RT+RL		
			24 : STF+RT+RM		
			25 : STR+RT+RM		
			26 : STF+RT+RL+RM		
			27 : STR+RT+RL+RM		
			28: RUN(Inverter runs forward)		
			29: STF/STR(use with RUN signal, when ON, motor runs reverse ; when OFF, motor runs forward)		
			30: RES(External reset function)		
			31: STOP(Use as three line control with RUN signal and STF-STR signal)		
			32: REX(Extend multi-speed to 16 levels)		
			33: PO(In "external mode", run programmed operation)		
			34: RES_E (External reset, valid only when alarm.)		
			35: MPO (In "external mode" run manual cycle operation.)		
			36: TRI(Triangle wave function)		
			37~38 : Reserved		
			39: STF/STR +STOP (Use with RUN signal, when ON, motor runs reverse, when OFF, motor stops then runs forward.)		
			40: P_MRS (Stops inverter output immediately by pulse signal input)		
41~42 : Reserved					
43: RUN_EN (Enable digital input terminal operation)					
44: PID_OFF (Enable digital input terminal turning off PID)					
45: Second frequency command source mode					
46~91 : Reserved					
92 : Fire mode command 1(RUN command included)					
93 : Fire mode command 2(RUN command excluded)					
P.84	03-01	Terminal STR input function	Same as 03-00	1	90

Parameter Number	Group	Name	Setting Range	Default	Page
P.85	03-11	Terminal A-C output function	0: RUN(Output when inverter running)	5	92
			1: SU(Output when reach target frequency)		
			2: FU(Output when reach 03-21 03-22 value)		
			3: OL(Output when overload)		
			4: OMD(Output when output current is zero)		
			5: ALARM(Output when alarm)		
			6: PO1(Output when in program operation step)		
			7: PO2(Output when in program operation cycle)		
			8: PO3(Output when in program operation pause)		
			9~10 : Reserved		
			11 : OMD1(Output when output current is zero 1)		
			12 : OL2(Output when over torque)		
			13~16 : Reserved		
			17: RY(Output when inverter is powered on and no alarm)		
			18: Output when it's time for maintenance		
19~40 : Reserved					
41 : PID feedback disconnection (AErr) alarm					
42 : Fire mode indication					
P.87	03-14	Digital input logic	0 ~ 15	0	93
P.88	03-15	Digital output logic	0 : Terminal A-C output positive logic	0	93
			2 : Terminal A-C output negative logic		
P.89	13-00	Slip compensation coefficient	0 ~ 10	0	156
P.90	00-00	Inverter model	Read only	---	49
P.91	01-16	Frequency jump 1A	0 ~ 650.00Hz	99999	72
			99999 : Off		
P.92	01-17	Frequency jump 1B	0 ~ 650.00Hz	99999	72
			99999 : Off		
P.93	01-18	Frequency jump 2A	0 ~ 650.00Hz	99999	72
			99999 : Off		
P.94	01-19	Frequency jump 2B	0 ~ 650.00Hz	99999	72
			99999 : Off		
P.95	01-20	Frequency jump 3A	0 ~ 650.00Hz	99999	72
			99999 : Off		
P.96	01-21	Frequency jump 3B	0 ~ 650.00Hz	99999	72
			99999 : Off		
P.97	00-17	Second target frequency selection	0: Frequency set by built-in keypad	0	59
			1: Frequency set by RS485 communication		
			2: Frequency set by analog input		
P.98	01-26	Middle frequency 1	0 ~ 650.00Hz	3.00Hz	75
P.99	01-27	Output voltage 1 of middle frequency	0 ~ 100.0%	10.0%	75

Appendix 1 Parameter table

Parameter Number	Group	Name	Setting Range	Default	Page
P.100	04-15	Programmed operation minute / second selection	0: Select minute as the time increment.	1	102
			1: Select second as the time increment.		
P.101	04-27	Programmed operation mode speed 1 operating time	0 ~ 6000.0s	0.0s	102
P.102	04-28	Programmed operation mode speed 2 operating time	0 ~ 6000.0s	0.0s	102
P.103	04-29	Programmed operation mode speed 3 operating time	0 ~ 6000.0s	0.0s	102
P.104	04-30	Programmed operation mode speed 4 operating time	0 ~ 6000.0s	0.0s	102
P.105	04-31	Programmed operation mode speed 5 operating time	0 ~ 6000.0s	0.0s	102
P.106	04-32	Programmed operation mode speed 6 operating time	0 ~ 6000.0s	0.0s	102
P.107	04-33	Programmed operation mode speed 7 operating time	0 ~ 6000.0s	0.0s	102
P.108	04-34	Programmed operation mode speed 8 operating time	0 ~ 6000.0s	0.0s	103
P.110	00-06	Built-in keypad monitor selection	X0 : When inverter starts, built-in keypad enters monitor mode automatically, screen displays output frequency (with slip compensation).	2	54
			X1 : When inverter starts, built-in keypad displays target frequency.		
			X2 : When inverter starts, built-in keypad enters monitor mode automatically, screen displays steady state output frequency		
			X3 : When inverter starts, built-in keypad enters monitor mode automatically, screen displays current pressure and feedback pressure of the constant pressure system in percentage		
			X4 : When inverter starts, built-in keypad doesn't enter monitor mode but enter the previous mode before power off		
			X5 : When inverter starts, built-in keypad enters monitor mode automatically, screen displays current pressure and feedback pressure of the constant pressure system		
P.111	04-35	Programmed operation mode speed 1 Acc/Dec time	0 ~ 600.00s/0 ~ 6000.0s	0.00s	103

Parameter Number	Group	Name	Setting Range	Default	Page
P.112	04-36	Programmed operation mode speed 2 Acc/Dec time	0 ~ 600.00s/0 ~ 6000.0s	0.00s	103
P.113	04-37	Programmed operation mode speed 3 Acc/Dec time	0 ~ 600.00s/0 ~ 6000.0s	0.00s	103
P.114	04-38	Programmed operation mode speed 4 Acc/Dec time	0 ~ 600.00s/0 ~ 6000.0s	0.00s	103
P.115	04-39	Programmed operation mode speed 5 Acc/Dec time	0 ~ 600.00s/0 ~ 6000.0s	0.00s	103
P.116	04-40	Programmed operation mode speed 6 Acc/Dec time	0 ~ 600.00s/0 ~ 6000.0s	0.00s	103
P.117	04-41	Programmed operation mode speed 7 Acc/Dec time	0 ~ 600.00s/0 ~ 6000.0s	0.00s	103
P.118	04-42	Programmed operation mode speed 8 Acc/Dec time	0 ~ 600.00s/0 ~ 6000.0s	0.00s	103
P.119	10-16	Forward and reverse rotation dead time	0 ~ 3000.0s	0.0s	150
P.120	03-16	Output signal delay time	0 ~ 3600.0s	0.0s	94
P.121	04-16	Run direction in each section	0 ~ 255	0	102
P.122	04-17	Programmed operation cycle selection	0:Off	0	102
			1 ~ 8: Start cycle from the set section.		
P.123	04-18	Programmed operation acceleration / deceleration time setting selection	0: Acceleration time is 01-06(P.7), deceleration time is 01-07(P.8).	0	102
			1: Acceleration and deceleration time is set by 04-35(P.111) ~ 04-42(P.118).		
P.131	04-19	Programmed operation mode speed 1	0 ~ 650.00Hz	0.00Hz	102
P.132	04-20	Programmed operation mode speed 2	0 ~ 650.00Hz	0.00Hz	102
P.133	04-21	Programmed operation mode speed 3	0 ~ 650.00Hz	0.00Hz	102
P.134	04-22	Programmed operation mode speed 4	0 ~ 650.00Hz	0.00Hz	102
P.135	04-23	Programmed operation mode speed 5	0 ~ 650.00Hz	0.00Hz	102
P.136	04-24	Programmed operation mode speed 6	0 ~ 650.00Hz	0.00Hz	102
P.137	04-25	Programmed operation mode speed 7	0 ~ 650.00Hz	0.00Hz	102
P.138	04-26	Programmed operation mode speed 8	0 ~ 650.00Hz	0.00Hz	102
P.141	02-61	Polarity of percentage corresponds to terminal 3-5 current/ voltage signal	0~11	0	80
P.142	04-07	Speed 8	Same as 04-03	0.00Hz	100
P.143	04-08	Speed 9	Same as 04-03	99999	100
P.144	04-09	Speed 10	Same as 04-03	99999	100
P.145	04-10	Speed 11	Same as 04-03	99999	100
P.146	04-11	Speed 12	Same as 04-03	99999	100
P.147	04-12	Speed 13	Same as 04-03	99999	100
P.148	04-13	Speed 14	Same as 04-03	99999	100
P.149	04-14	Speed 15	Same as 04-03	99999	100

Appendix 1 Parameter table

Parameter Number	Group	Name	Setting Range	Default	Page
P.150	10-08	Restart mode selection	X0 : No frequency search.	0	146
			X1 : Reserved		
			X2 : Decrease voltage mode		
			0X : Power on once.		
			1X : Start each time.		
			2X : Only instantaneous stop and restart		
			3X : Only valid when the inverter resets in fire mode		
P.151	10-03	Zero-speed control function selection	0: Off.	0	145
			1: DC voltage braking		
P.152	10-04	Voltage at zero-speed control	7.5K/11KF and below model : 0 ~ 30.0%	5.0%	145
			11K/15KF and above model : 0 ~ 30.0%	2.0%	
P.153	07-10	Communication alarm action	0 : Alarm and stop freely	0	120
			1 : No alarm and continuing to operation		
P.154	07-07	Modbus communication format	0 : 1、7、N、2 (Modbus, ASCII)	4	120
			1 : 1、7、E、1 (Modbus, ASCII)		
			2 : 1、7、O、1 (Modbus, ASCII)		
			3 : 1、8、N、2 (Modbus, RTU)		
			4 : 1、8、E、1 (Modbus, RTU)		
			5 : 1、8、O、1 (Modbus, RTU)		
			6 : 1、8、N、1 (Modbus, RTU)		
P.155	06-08	Over torque detection level	0 ~ 200.0%	0.0%	113
P.156	06-09	Over torque detection time	0 ~ 60.0s	1.0s	113
P.157	03-17	Digital input terminal filter time	0 ~ 2000	4	94
P.158	03-18	Digital input terminal enable when power on	0: When power on digital terminals work directly	0	95
			1: When power on digital terminals work after switch off then on		
P.159	10-17	Energy-saving control function	0: Off.	0	150
			1: Energy-saving mode.		
P.161	00-07	Multi-function display	0: Output AC voltage (V)	0	54
			1: DC bus voltage. (V)		
			2: Inverter temperature rising accumulation rate (%)		
			3: Target pressure of the constant pressure system (%)		
			4: Feedback pressure of the constant pressure system (%)		
			5: Running frequency (Hz)		
			6: Electronic thermal accumulation rate (%)		
			7 : Reserved		
			8: Signal value (mA) of 3-5 input terminals (mA/V).		
			9 : Output power (kW)		

Appendix 1 Parameter table

Parameter Number	Group	Name	Setting Range	Default	Page
P.161	00-07	Multi-function display	11: Forward reverse rotation signal. Built-in keypad: Frd is forward , rEv is reverse , STOP is not operating status. External keypad:1 is forward , 2 is reverse, 0 is not operating status..	0	54
			12: NTC temperature (°C)		
			13 : Motor electronic thermal accumulation rate (%)		
			14~18 : Reserved		
			19: Digital terminal input state		
			20: Digital terminal output state		
			21: Actual working carrier frequency		
P.162	01-28	Middle frequency 2	0 ~ 650.00Hz	99999	75
			99999 : Off		
P.163	01-29	Output voltage 2 of middle frequency	0 ~ 100.0%	0.0%	75
P.164	01-30	Middle frequency 3	0 ~ 650.00Hz	99999	75
			99999 : Off		
P.165	01-31	Output voltage 3 of middle frequency	0 ~ 100.0%	0.0%	75
P.166	01-32	Middle frequency 4	0 ~ 650.00Hz	99999	75
			99999 : Off		
P.167	01-33	Output voltage 4 of middle frequency	0 ~ 100.0%	0.0%	75
P.168	01-34	Middle frequency 5	0 ~ 650.00Hz	99999	75
			99999 : Off		
P.169	01-35	Output voltage 5 of middle frequency	0 ~ 100.0%	0.0%	75
P.170	08-00	PID function selection	0: Off	0	137
			2 : Parameter 08-03(P.225) as target value, terminal 3-5 current/voltage input as feedback source		
			3 : Target value is set by multi-speed value, and feedback from terminal 3-5 current/voltage input		
P.171	08-01	PID feedback control method	0: Negative feedback control.	0	137
			1: Positive feedback control.		
P.172	08-04	Proportional gain	1~100	20	137
P.173	08-05	Integral time	0 ~ 100.0s	1.0s	137
P.174	08-06	Differential time	0 ~ 1000ms	0ms	137
P.175	08-07	Abnormal deviation	0 ~ 200.0%	0.0%	137
P.176	08-08	Abnormal duration time	0 ~ 600.0s	30.0s	137
P.177	08-09	Abnormal processing mode	0: Stop freely	0	137
			1: Slow down to stop		
			2: Alarm and continue operation		
P.178	08-10	Sleep detection deviation	0 ~ 100.0%	0.0%	137
P.179	08-11	Sleep detection duration time	0 ~ 255.0s	1.0s	138

Appendix 1 Parameter table

Parameter Number	Group	Name	Setting Range	Default	Page
P.180	08-12	Wake-up level	0 ~ 200.0%	90.0%	138
P.181	08-13	Stop level	0 ~ 120.00Hz	40.00Hz	138
P.182	08-14	Upper integral limit	50Hz system:0 ~ 120.00Hz	50.00Hz	138
			60Hz system:0 ~ 120.00Hz	60.00Hz	
P.183	08-15	Deceleration step length when stable	0 ~ 10.00Hz	0.50Hz	138
P.184	02-24	Terminal 3-5 disconnect selection	0: Off	0	80
			1: Inverter decelerates to 0Hz, multi-function digital output terminal set off alarm		
			2: Inverter stops immediately, and keypad displays "AEr" alarm		
			3: Inverter runs continuously according to the frequency command before disconnection. Digital output terminal will set off alarm.		
P.185	02-06	Proportional linkage gain	0 ~ 100%	0%	78
P.186	00-23	Motor types selection	0: Normal Duty (ND), on fan and pump duty type.	1	60
			1: Heavy Duty (HD), apply to other duties.		
P.188	00-01	Firmware version	Read only	---	49
P.189	00-24	50Hz/60Hz switch selection	0: Frequency related parameter default value is 60Hz.	0	61
			1: Frequency related parameter default value is 50Hz.	1	
P.196	02-27	Percentage corresponds to terminal 3-5 minimum input current/ voltage	0% ~ 100.0%	0.0%	80
P.197	02-28	Percentage corresponds to terminal 3-5 maximum input current/ voltage	0% ~ 100.0%	100.0%	80
P.198	02-25	Terminal 3-5 minimum input current/ voltage	0 ~ 20.00 mA /V	0.00V	80
P.199	02-26	Terminal 3-5 maximum input current/ voltage	0 ~ 20.00 mA/ V	10.00V	80
P.207	06-84	Fire Mode	XXX0:Invalid(fire mode is forbidden(normal mode))	0	117
			XXX1:Forward operation(the inverter runs forward in fire mode)		
			XXX2:Reverse operation(the inverter runs reversely in fire mode)		
			0XXX:Manually exit fire mode 1: if the start fire mode terminal is OFF, the inverter need reset manually and back to normal mode		
			1XXX:Exit fire mode automatically: if the start fire mode terminal is OFF, the inverter goes to normal mode automatically		
			2XXX:Manually exit fire mode 2 :if the start fire mode terminal is OFF, the inverter keeps running, need reset manually and back to normal mode		

Appendix 1 Parameter table

Parameter Number	Group	Name	Setting Range	Default	Page
P.208	06-85	Frequency setting in fire mode	0~650.00Hz	60.00Hz	117
P.209	06-88	Accumulated times in fire mode	Read only	Read only	117
P.219	01-40	Remote function acc/dec time selection	0 : Use default acc/dec time (same as regular mode)	0	77
			1 : Use second acc/dec time		
P.223	08-18	Analog feedback signal bias	0 ~ 100.0%	0.0%	138
P.224	08-19	Analog feedback signal gain	0 ~ 100.0%	100.0%	138
P.225	08-03	PID target value from keypad	0 ~ 08-43(P.251)	20.0%	137
P.226	10-55	Reciprocating machine function selection	0 : Off	0	153
			1 : Turn on reciprocating machine function		
P.227	10-56	Reciprocating forward limit time	0~3600.0s	0.0s	153
P.228	10-57	Reciprocating reverse limit time	0~3600.0s	0.0s	153
P.229	10-18	Dwell function selection	0: Off.	0	151
			1: Backlash compensation function.		
			2: Acceleration and deceleration interrupt waiting function.		
P.230	10-19	Dwell frequency at acceleration	0 ~ 650.00Hz	1.00Hz	151
P.231	10-20	Dwell time at acceleration	0 ~ 360.0s	0.5s	151
P.232	10-21	Dwell frequency at deceleration	0 ~ 650.00Hz	1.00Hz	151
P.233	10-22	Dwell time at deceleration	0 ~ 360.0s	0.5s	151
P.234	10-23	Triangular wave function selection	0: Off.	0	152
			1: If terminal function TRI is triggered, triangular wave function will on.		
			2: Triangular wave function is on at all time.		
P.235	10-24	Maximum amplitude	0 ~ 25.0%	10.0%	152
P.236	10-25	Amplitude compensation at deceleration	0 ~ 50.0%	10.0%	152
P.237	10-26	Amplitude compensation at acceleration	0 ~ 50.0%	10.0%	152
P.238	10-27	Amplitude acceleration time	0 ~ 360.00s/0 ~ 3600.0s	10.00s	152
P.239	10-28	Amplitude deceleration time	0 ~ 360.00s/0 ~ 3600.0s	10.00s	152
P.240	02-07	Auxiliary frequency	0: Off	0	79
			2: Output frequency = basic frequency + auxiliary frequency (given by terminal 3-5)		
			4: Output frequency = basic frequency - auxiliary frequency (given by terminal 3-5)		
			6: Output frequency = proportional linkage signal (given by terminal 3-5)		

Appendix 1 Parameter table

Parameter Number	Group	Name	Setting Range	Default	Page
P.242	10-05	DC brake before inverter start	0: Off	0	145
			1: Before starting operate DC brake first.		
P.243	10-06	DC brake time before inverter start	0 ~ 60.0s	0.5s	145
P.244	10-07	DC brake voltage before inverter start	7.5K/11KF and below model : 0 ~ 30.0%	4.0%	145
			11K/15KF and above model : 0 ~ 30.0%	2.0%	
P.245	06-12	Cooling fan working mode	0 :When running turn on the fan, after stop for 30 seconds turn off the fan.	1	112
			1 : When power on turn on the fan, after power off turn off the fan.		
			2 : When running and the heat sink temperature exceeds 60°C turn on the fan, under 40°C turn off the fan.		
			3 : When the heat sink temperature exceeds 60°C turn on the fan, under 40°C turn off the fan.		
P.251	08-43	PID pressure range (Bar) setting	1.0~100.0	100.0	141
P.253	08-45	Analog signal feedback loss detection time	0.0~600.0s	0.0s	141
P.254	08-46	Analog signal feedback loss action selection	0 : Alarm AErr and inverter stop freely	0	141
			1 : Slow down to stop then alarm AErr		
			2 : Alarm AErr and continue operation		
P.255	01-36	S curve time at the beginning of acceleration	0 ~ 25.00s/0 ~ 250.0s	0.20s	76
P.256	01-37	S curve time at the end of acceleration	0 ~ 25.00s/0 ~ 250.0s	99999	76
			99999 : Off		
P.257	01-38	S curve time at the beginning of deceleration	0 ~ 25.00s/0 ~ 250.0s	99999	76
			99999 : Off		
P.258	01-39	S curve time at the end of deceleration	0 ~ 25.00s/0 ~ 250.0s	99999	76
			99999 : Off		
P.259	00-09	Speed display unit selection	0: Speed display unit is 1	1	55
			1: Speed display unit is 0.1		
P.260	06-10	Action when detect over torque	0: OL2 alarm will not be reported after over torque detection, and inverter keeps running.	1	113
			1: OL2 alarm will be reported after over torque detection, and inverter stops.		
P.261	06-17	Maintenance alarm function	0: Off	0	114
			1 ~ 9998day: Used to set the time for maintenance alarm output signal		
P.268	10-46	Voltage stall level	220V : 155 ~ 410V	380V	153
			440V : 310 ~ 820V	760V	

Appendix 1 Parameter table

Parameter Number	Group	Name	Setting Range	Default	Page
P.280	06-18	Short circuit to ground protection function when start	XX0 : Off	0	114
			XX1 : Detect leakage current of ground when inverter starts		
			0X1 : Detect leakage current of ground only for the first startup		
			1X1 : Detect leakage current of ground for every startup.		
P.281	06-13	Input phase loss protection	0: Off 1: When input phase loss, built-in keypad shows IPF alarm and inverter stops	0	114
P.282	06-19	GF detection level when operating	0 ~ 100%	50%	114
P.286	13-03	High frequency vibration suppression factor	0.2K~5.5K model : 0 ~ 1515	300	156
			7.5K/11KF and above : 0 ~ 1515	509	
P.288	06-40	Alarm record code query	Choose 0 ~ 12 recorded alarm	0	116
P.289	06-41	Alarm record code display	Read only	Read only	116
P.290	06-42	Alarm record message query	Choose 0 ~ 10 recorded alarm	0	116
P.291	06-43	Alarm record message display	Read only	Read only	116
P.292	06-27	Total inverter operation time (minutes)	0 ~ 1439 min	0min	115
P.293	06-28	Total inverter operation time (days)	0 ~ 9999 day	0day	115
P.294	00-04	Password parameter	0~65535	0	52
P.295	00-05	Password setup	2~65535	0	52
P.296	06-29	Total inverter power on time (minutes)	0 ~ 1439 min	0min	115
P.297	06-30	Total inverter power on time (days)	0 ~ 9999 day	0day	115
P.300	00-21	Motor control mode selection	0: Induction motor V/F control	0	60
			1. Reserved		
			2 : Induction motor simple vector control		
P.301	05-00	Motor specifications automatic measurement	0: Off	0	105
			1: Induction motor specifications automatic measurement (Run motor to measure)		
			2: Induction motor specifications automatic measurement (Don't run motor to measure)		
			3: Induction motor specifications automatic measurement (Measure when operating)		
P.302	05-01	Motor rated power	0 ~ 160.00kW	0.00kW	107
P.303	05-02	Motor poles	0 ~ 256	4	107
P.304	05-03	Motor rated voltage	0 ~ 510V	380V/440V	107
				220V	
P.305	05-04	Motor rated frequency	50Hz system : 0 ~ 650.00Hz	50.00Hz	107
			60Hz system : 0 ~ 650.00Hz	60.00Hz	
P.306	05-05	Motor rated current	0~500.0A	According to kw	107
P.307	05-06	Motor rated rotation speed	50Hz system : 0 ~ 65000r/min	1410r/min	107
			60Hz system : 0 ~ 65000r/min	1710r/min	
P.308	05-07	IM Motor excitation current	0~500.00A	According to kw	107

Appendix 1 Parameter table

Parameter Number	Group	Name	Setting Range	Default	Page	
P.309	05-08	IM motor stator resistance	0 ~ 99.98Ω :	According to kw	107	
P.320	11-00	Slip compensation gain	0~200%	85%	155	
P.321	11-01	Torque boost filter coefficient	0 ~ 2000	20	155	
P.322	11-02	Cutoff frequency point of current filter time 1	0~30.00Hz	4.00Hz	155	
P.323	11-03	Current filter time 1	0~400.00ms	According to kw	155	
P.324	11-04	Low frequency current filter time 2	0~400.00ms	According to kw	155	
P.325	11-05	High frequency current filter time 2	0~400.00ms	According to kw	155	
P.900	15-00	User registered parameter 1	P parameter mode: 0~399 Parameter group mode: 00-00~13-99	99999	158	
P.901	15-01	User registered parameter 2		99999	158	
P.902	15-02	User registered parameter 3		99999	158	
P.903	15-03	User registered parameter 4		99999	158	
P.904	15-04	User registered parameter 5		99999	158	
P.905	15-05	User registered parameter 6		99999	158	
P.906	15-06	User registered parameter 7		99999	158	
P.907	15-07	User registered parameter 8		99999	158	
P.908	15-08	User registered parameter 9		P parameter mode: 0~399 Parameter group mode: 00-00~13-99	99999	158
P.909	15-09	User registered parameter 10			99999	158
P.910	15-10	User registered parameter 11			99999	158
P.911	15-11	User registered parameter 12			99999	158
P.912	15-12	User registered parameter 13			99999	158
P.913	15-13	User registered parameter 14			99999	158
P.914	15-14	User registered parameter 15			99999	158
P.915	15-15	User registered parameter 16			99999	158
P.916	15-16	User registered parameter 17			99999	158
P.917	15-17	User registered parameter 18			99999	158
P.918	15-18	User registered parameter 19			99999	158
P.919	15-19	User registered parameter 20			99999	158
P.990	00-25	Parameter display mode setting	0: Parameter is displayed in "group mode"	0	61	
			1: Parameter is displayed in "sequence P mode"			
P.996 ~ P.999	00-02	Parameter restoration	0: Off	0	50	
			1: Clear alarm history (P.996=1)			
			2: Reset inverter (P.997=1)			
			3: Restore all parameters to default (P.998=1)			
			4: Restore some parameters to default 1 (P.999=1)			
			5: Restore some parameters to default 2 (P.999=2)			
			6: Restore some parameters to default 3 (P.999=3)			

7.1.2 Group mode

Group	Parameter Number	Name	Setting Range	Default	Page
00-00	P.90	Inverter model	Read only	---	49
00-01	P.188	Firmware version	Read only	---	49
00-02	P.996 ~ P.999	Parameter restoration	0: Off	0	50
			1: Clear alarm history (P.996=1)		
			2: Reset inverter (P.997=1)		
			3: Restore all parameters to default (P.998=1)		
			4: Restore some parameters to default 1 (P.999=1)		
			5: Restore some parameters to default 2 (P.999=2)		
00-03	P.77	Selection of parameters write protection	0: Parameters can be written only when the motor stops.	0	52
			1: Parameters cannot be written.		
			2: Parameters can also be written when the motor is running.		
			3: Parameters cannot be read when in password protection.		
00-04	P.294	Password parameter	0~65535	0	52
00-05	P.295	Password setup	2~65535	0	52
00-06	P.110	Built-in keypad monitor selection	X0 :When inverter starts, built-in keypad enters monitor mode automatically, screen displays output frequency (with slip compensation).	2	54
			X1 : When inverter starts, built-in keypad displays target frequency.		
			X2 :When inverter starts, built-in keypad enters monitor mode automatically, screen displays steady state output frequency		
			X3 :When inverter starts, built-in keypad enters monitor mode automatically, screen displays current pressure and feedback pressure of the constant pressure system in percentage		
			X4 : When inverter starts, built-in keypad doesn't enter monitor mode but enter the previous mode before power off		
			X5 :When inverter starts, built-in keypad enters monitor mode automatically, screen displays current pressure and feedback pressure of the constant pressure system		
			4X :When the inverter is standby, the keypad goes into target frequency mode automatically and figure blinks on the keypad panel		
00-07	P.161	Multi-function display	0: Output AC voltage (V)	0	54
			1: DC bus voltage. (V)		
			2: Inverter temperature rising accumulation rate (%)		
			3: Target pressure of the constant pressure system (%)		
			4: Feedback pressure of the constant pressure system (%)		
			5: Running frequency (Hz)		
			6: Electronic thermal accumulation rate (%)		
			7 : Reserved		
8: Signal value (mA) of 3-5 input terminals (mA/V).					

Appendix 1 Parameter table

Group	Parameter Number	Name	Setting Range	Default	Page
00-07	P.161	Multi-function display	9: Output power (kW).	0	54
			10 : Reserved		
			11: Forward reverse rotation signal. Built-in keypad: Frd is forward , rEv is reverse , STOP is not operating status. External keypad:1 is forward , 2 is reverse, 0 is not operating status..		
			12: NTC temperature (°C)		
			13 : Motor electronic thermal accumulation rate (%)		
			14~18 : Reserved		
			19: Digital terminal input state		
			20: Digital terminal output state		
			21: Actual working carrier frequency		
			00-08		
0.1~5000.0					
1~50000					
00-09	P.259	Speed display unit selection	0: Speed display unit is 1	1	55
			1: Speed display unit is 0.1		
00-10	P.59	Built-in keypad set target frequency selection	XXX0: Use wheel on built-in keypad or external keypad to set frequency	0	56
			XXX1: Use keypad knob on external keypad to set frequency		
			X0XX: Frequency change done and setting saves in 30 seconds		
			X1XX: Frequency change done and setting saves in 10 seconds		
			X2XX: Every frequency change will not save		
			0XXX: Set frequency will work immediately when use wheel on built-in keypad		
			1XXX: Set frequency will work after pressing SET when use wheel on built-in keypad		
00-11	P.72	Carrier frequency	11K/15KF and below model : 1~15kHz	5 kHz	57
			15K/18.5KF and above Heavy Duty : 1~15kHz		
			15K/18.5KF and above Normal Duty : 1~10kHz		
00-12	P.31	Soft-PWM carrier function selection	0: Off	0	57
			1: When 00-11(P.72)<5,Soft-PWM is on(only apply to V/F control)		
			2 : When 00-11(P.72) > 9, if the IGBT temperature is higher than 60°C, carrier frequency will decrease automatically, when temperature go back to under 40°C, carrier frequency go back to 00-11(P.72) value.		
00-13	P.71	Idling brake / DC brake	0: Idling brake	1	58
			1: DC brake		
00-14	P.75	Stop function selection	0: Press STOP button and inverter stop running in PU and H2 mode	1	58
			1: Press STOP button and inverter stop running in all mode.		

Appendix 1 Parameter table

Group	Parameter Number	Name	Setting Range	Default	Page
00-15	P.78	Prevent forward/reverse rotation selection	0: Forward/reverse rotation are both permitted.	0	59
			1: Prevent reverse rotation (Giving reverse signal decelerates and stops the motor).		
			2: Prevent forward rotation (Giving forward signal decelerates and stops the motor).		
00-16	P.79	Operation mode selection	0: "PU mode", "external mode" and "Jog mode" are interchangeable.	0	59
			1: "PU mode" and "JOG mode" are interchangeable.		
			2: "External mode" only		
			3: "Communication mode" only		
			4: "Combined mode 1"		
			5: "Combined mode 2"		
			6: "Combined mode 3"		
			7: "Combined mode 4"		
8: "Combined mode 5"					
00-17	P.97	Second target frequency selection	0: Frequency set by built-in keypad	0	59
			1: Frequency set by RS485 communication		
			2: Frequency set by analog input		
00-19	P.35	Communication mode selection	0: In communication mode, run signal and frequency is given by communication.	0	59
			1: In communication mode, run signal and frequency is given by external signal.		
00-21	P.300	Motor control mode selection	0: Induction motor V/F control	0	60
			1:Reserved		
			2:Induction motor simple vector control		
00-23	P.186	Motor types selection	0: Normal Duty (ND), on fan and pump duty type	1	60
			1: Heavy Duty (HD), apply to other duties		
00-24	P.189	50Hz/60Hz switch selection	0: Frequency related parameter default value is 60Hz.	0	61
			1: Frequency related parameter default value is 50Hz.	1	
00-25	P.990	Parameter display mode setting	0: Parameter is displayed in "group mode"	0	61
			1: Parameter is displayed in "sequence P mode"		
01-00	P.1	Maximum frequency	0.00 ~ 01-02 (P.18) Hz	120.00Hz	64
01-01	P.2	Minimum frequency	0 ~ 120.00Hz	0.00Hz	64
01-02	P.18	High-speed maximum frequency	01-00 (P.1) ~ 650.00Hz	120.00Hz	64
01-03	P.3	Base frequency	50Hz system setting: 0 ~ 650.00Hz	50.00Hz	65
			60Hz system setting: 0 ~ 650.00Hz	60.00Hz	
01-04	P.19	Base voltage	0 ~ 1000.0V	99999	65
			99999 : Change according to the input voltage		

Appendix 1 Parameter table

Group	Parameter Number	Name	Setting Range	Default	Page
01-05	P.29	Acceleration/deceleration curve selection	0: Linear acceleration /deceleration curve	0	66
			1: S shape acceleration /deceleration curve 1		
			2: S shape acceleration /deceleration curve 2		
			3: S shape acceleration /deceleration curve 3		
01-06	P.7	Acceleration time	3.7K and below : 0 ~ 360.00s/0 ~ 3600.0s	5.00s	66
			5.5K model : 0 ~ 360.00s/0 ~ 3600.0s	10.00s	
			7.5K/11KF and above model : 0 ~ 360.00s/0 ~ 3600.0s	20.00s	
01-07	P.8	Deceleration time	3.7K and below : 0 ~ 360.00s/0 ~ 3600.0s	5.00s	66
			5.5K~7.5K/11KF model : 0 ~ 360.00s/0 ~ 3600.0s	10.00s	
			7.5K/11KF and above model : 0 ~ 360.00s/0 ~ 3600.0s	30.00s	
01-08	P.21	Acceleration/deceleration time increments	0: Time increment is 0.01s	0	66
			1: Time increment is 0.1s		
01-09	P.20	Acceleration/deceleration reference frequency	50Hz system setting: 1.00 ~ 650.00Hz	50.00Hz	66
			60Hz system setting: 1.00 ~ 650.00Hz	60.00Hz	
01-10	P.0	Torque boost	0.75K and under :0 ~ 30.0%	6.0%	68
			1.5K~3.7K model : 0 ~ 30.0%	4.0%	
			5.5K ~7.5K/11KF model : 0 ~ 30.0%	3.0%	
			11K/15KF and above model : 0 ~ 30.0%	2.0%	
01-11	P.13	Starting frequency	0 ~ 60.00Hz	0.50Hz	68
01-12	P.14	Load pattern selection	0: For constant torque loads (conveyor belt, etc.)	0	69
			1: For variable torque loads (fans and pumps, etc.)		
			2 ~ 3 : For Lifting loads		
			4: Multipoint V/F curve		
			5~13: Special two-point V/F curve		
01-13	P.15	JOG frequency	0 ~ 650.00Hz	5.00Hz	71
01-14	P.16	JOG Acc/ Dec time	0 ~ 360.00s/0 ~ 3600.0s	0.50s	71
01-15	P.28	Output frequency filter time	0 ~ 31	0	72
01-16	P.91	Frequency jump 1A	0 ~ 650.00Hz	99999	72
			99999 : Off		
01-17	P.92	Frequency jump 1B	0 ~ 650.00Hz	99999	72
			99999 : Off		
01-18	P.93	Frequency jump 2A	0 ~ 650.00Hz	99999	72
			99999 : Off		
01-19	P.94	Frequency jump 2B	0 ~ 650.00Hz	99999	72
			99999 : Off		
01-20	P.95	Frequency jump 3A	0 ~ 650.00Hz	99999	72
			99999 : Off		
01-21	P.96	Frequency jump 3B	0 ~ 650.00Hz	99999	72
			99999 : Off		
01-22	P.44	Second acceleration time	0 ~ 360.00s/0 ~ 3600.0s	99999	74
			99999 : Off		

Appendix 1 Parameter table

Group	Parameter Number	Name	Setting Range	Default	Page
01-23	P.45	Second deceleration time	0 ~ 360.00s/0 ~ 3600.0s	99999	74
			99999 : Off		
01-24	P.46	Second torque boost	0 ~ 30.0%	99999	74
			99999 : Off		
01-25	P.47	Second base frequency	0 ~ 650.00Hz	99999	74
			99999 : Off		
01-26	P.98	Middle frequency 1	0 ~ 650.00Hz	3.00Hz	75
01-27	P.99	Output voltage 1 of middle frequency	0 ~ 100.0%	10.0%	75
01-28	P.162	Middle frequency 2	0 ~ 650.00Hz	99999	75
			99999 : Off		
01-29	P.163	Output voltage 2 of middle frequency	0 ~ 100.0%	0.0%	75
01-30	P.164	Middle frequency 3	0 ~ 650.00Hz	99999	75
			99999 : Off		
01-31	P.165	Output voltage 3 of middle frequency	0 ~ 100.0%	0.0%	75
01-32	P.166	Middle frequency 4	0 ~ 650.00Hz	99999	75
			99999 : Off		
01-33	P.167	Output voltage 4 of middle frequency	0 ~ 100.0%	0.0%	75
01-34	P.168	Middle frequency 5	0 ~ 650.00Hz	99999	75
			99999 : Off		
01-35	P.169	Output voltage 5 of middle frequency	0 ~ 100.0%	0.0%	75
01-36	P.255	S curve time at the beginning of acceleration	0 ~ 25.00s/0 ~ 250.0s	0.20s	76
01-37	P.256	S curve time at the end of acceleration	0 ~ 25.00s/0 ~ 250.0s	99999	76
			99999 : Off		
01-38	P.257	S curve time at the beginning of deceleration	0 ~ 25.00s/0 ~ 250.0s	99999	76
			99999 : Off		
01-39	P.258	S curve time at the end of deceleration	0 ~ 25.00s/0 ~ 250.0s	99999	76
			99999 : Off		
01-40	P.219	Remote function acc/dec time selection	0 : Use default acc/dec time (same as regular mode)	0	77
			1 : Use second acc/dec time		
02-06	P.185	Proportional linkage gain	0 ~ 100%	0%	78
02-07	P.240	Auxiliary frequency	0: Off	0	79
			2: Output frequency = basic frequency + auxiliary frequency (given by terminal 3-5)		
			4: Output frequency = basic frequency - auxiliary frequency (given by terminal 3-5)		
			6: Output frequency = proportional linkage signal (given by terminal 3-5)		
02-10	P.60	Terminal 3-5 filter time	0 ~ 2000ms	31ms	80

Appendix 1 Parameter table

Group	Parameter Number	Name	Setting Range	Default	Page
02-20	P.17	Terminal 3-5 signal range selection	0: Signal sampling range from 4~20mA.	1	80
			1: Signal sampling range from 0 ~ 10V.		
			2: Signal sampling range from 0 ~ 5V.		
02-21	P.39	Terminal 3-5 maximum operation frequency	50Hz system:1.00 ~ 650.00Hz	50.00Hz	80
			60Hz system:1.00 ~ 650.00Hz	60.00Hz	
02-24	P.184	Terminal 3-5 disconnect selection	0: Off	0	80
			1: Inverter decelerates to 0Hz, multi-function digital output terminal set off alarm		
			2: Inverter stops immediately, and keypad displays "AErr" alarm		
			3: Inverter runs continuously according to the frequency command before disconnection. Digital output terminal will set off alarm.		
02-25	P.198	Terminal 3-5 minimum input current/ voltage	0 ~ 20.00 mA /V	0.00V	80
02-26	P.199	Terminal 3-5 maximum input current/ voltage	0 ~ 20.00 mA/ V	10.00V	80
02-27	P.196	Percentage corresponds to terminal 3-5 minimum input current/ voltage	0% ~ 100.0%	0.0%	80
02-28	P.197	Percentage corresponds to terminal 3-5 maximum input current/ voltage	0% ~ 100.0%	100.0%	80
02-52	P.56	Inverter rated current display level	0~500.00A	According to model	85
02-61	P.141	Polarity of percentage corresponds to terminal 3-5 current/ voltage signal	0~11	0	80
03-00	P.83	Terminal STF input function	0: STF(Inverter runs forward)	0	90
			1: STR(Inverter runs reverse)		
			2: RL(Multi-speed low speed)		
			3: RM(Multi-speed medium speed)		
			4: RH(Multi-speed high speed)		
			5: Reserved		
			6: External thermal relay actuate		
			7: MRS(Stops inverter output immediately)		
			8: RT(Inverter second function)		
			9: EXJ(External JOG)		
			10 : STF+EXJ		
			11 : STR+EXJ		
12 : STF+RT					

Group	Parameter Number	Name	Setting Range	Default	Page
03-00	P.83	Terminal STF input function	13 : STR+RT	0	90
			14 : STF+RL		
			15 : STR+RL		
			16 : STF+RM		
			17 : STR+RM		
			18 : STF+RH		
			19 : STR+RH		
			20 : STF+RL+RM		
			21 : STR+RL+RM		
			22 : STF+RT+RL		
			23 : STR+RT+RL		
			24 : STF+RT+RM		
			25 : STR+RT+RM		
			26 : STF+RT+RL+RM		
			27 : STR+RT+RL+RM		
			28: RUN(Inverter runs forward)		
			29: STF/STR(use with RUN signal, when ON, motor runs reverse ; when OFF, motor runs forward)		
			30: RES(External reset function)		
			31: STOP(Use as three line control with RUN signal and STF-STR signal)		
			32: REX(Extend multi-speed to 16 levels)		
			33: PO(In "external mode", run programmed operation)		
			34: RES_E (External reset, valid only when alarm.)		
			35: MPO (In "external mode" run manual cycle operation.)		
			36: TRI(Triangle wave function)		
			37~38 : Reserved		
			39: STF/STR +STOP (Use with RUN signal, when ON, motor runs reverse, when OFF, motor stops then runs forward.)		
			40: P_MRS (Stops inverter output immediately by pulse signal input)		
			41~42 : Reserved		
			43: RUN_EN (Enable digital input terminal operation)		
			44: PID_OFF (Enable digital input terminal turning off PID)		
45: Second frequency command source mode					
46~91 : Reserved					
92 : Fire mode command 1(RUN command included)					
93 : Fire mode command 2(RUN command excluded)					
03-01	P.84	Terminal STR input function	Same as 03-00	1	90

Appendix 1 Parameter table

Group	Parameter Number	Name	Setting Range	Default	Page
03-03	P.80	Terminal M0 input function	Same as 03-00	2	90
03-04	P.81	Terminal M1 input function	Same as 03-00	3	90
03-11	P.85	Terminal A-C output function	0: RUN(Output when inverter running)	5	93
			1: SU(Output when reach target frequency)		
			2: FU(Output when reach 03-21 03-22 value)		
			3: OL(Output when overload)		
			4: OMD(Output when output current is zero)		
			5: ALARM(Output when alarm)		
			6: PO1(Output when in program operation step)		
			7: PO2(Output when in program operation cycle)		
			8: PO3(Output when in program operation pause)		
			9~10 : Reserved		
			11 : OMD1(Output when output current is zero 1)		
			12 : OL2(Output when over torque)		
			13 ~ 16 : Reserved		
			17: RY(Output when inverter is powered on and no alarm)		
			18: Output when it's time for maintenance		
19~40 : Reserved					
41 : PID feedback disconnection (AErr) alarm					
42 : Fire mode indication					
03-14	P.87	Digital input logic	0 ~ 15	0	94
03-15	P.88	Digital output logic	0 : Terminal A-C output positive logic	0	94
			2 : Terminal A-C output negative logic		
03-16	P.120	Output signal delay time	0 ~ 3600.0s	0.0s	95
03-17	P.157	Digital input terminal filter time	0 ~ 2000	4	95
03-18	P.158	Digital input terminal enable when power on	0: When power on digital terminals work directly	0	96
			1: When power on digital terminals work after switch off then on		
03-20	P.41	Output frequency detection sensitivity	0 ~ 100.0%	10.0%	96
03-21	P.42	Output frequency detection for forward rotation	0 ~ 650.00Hz	6.00Hz	96
03-22	P.43	Output frequency detection for reverse rotation	0 ~ 650.00Hz	99999	96
			99999: Same as the setting of 03-21(P.42)		
03-23	P.62	Zero current detection level	0 ~ 200.0%	5.0%	97
			99999: Off		

Appendix 1 Parameter table

Group	Parameter Number	Name	Setting Range	Default	Page
03-24	P.63	Zero current detection time	0.05 ~ 100.00s	0.50s	97
			99999: Off		
04-00	P.4	Speed 1 (high speed)	0 ~ 650.00Hz	60.00Hz	100
04-01	P.5	Speed 2 (medium speed)	0 ~ 650.00Hz	30.00Hz	100
04-02	P.6	Speed 3 (low speed)	0 ~ 650.00Hz	10.00Hz	100
04-03	P.24	Speed 4	0 ~ 650.00Hz	99999	100
			99999: Off		
04-04	P.25	Speed 5	Same as 04-03	99999	100
04-05	P.26	Speed 6	Same as 04-03	99999	100
04-06	P.27	Speed 7	Same as 04-03	99999	100
04-07	P.142	Speed 8	Same as 04-03	0.00Hz	100
04-08	P.143	Speed 9	Same as 04-03	99999	100
04-09	P.144	Speed 10	Same as 04-03	99999	100
04-10	P.145	Speed 11	Same as 04-03	99999	100
04-11	P.146	Speed 12	Same as 04-03	99999	100
04-12	P.147	Speed 13	Same as 04-03	99999	100
04-13	P.148	Speed 14	Same as 04-03	99999	100
04-14	P.149	Speed 15	Same as 04-03	99999	100
04-15	P.100	Programmed operation minute / second selection	0: Select minute as the time increment.	1	102
			1: Select second as the time increment.		
04-16	P.121	Run direction in each section	0 ~ 255	0	102
04-17	P.122	Programmed operation cycle selection	0:Off	0	102
			1 ~ 8: Start cycle from the set section.		
04-18	P.123	Programmed operation acceleration / deceleration time setting selection	0: Acceleration time is 01-06(P.7), deceleration time is 01-07(P.8).	0	102
			1: Acceleration and deceleration time is set by 04-35(P.111) ~ 04-42(P.118).		
04-19	P.131	Programmed operation mode speed 1	0 ~ 650.00Hz	0.00 Hz	102
04-20	P.132	Programmed operation mode speed 2	0 ~ 650.00Hz	0.00 Hz	102
04-21	P.133	Programmed operation mode speed 3	0 ~ 650.00Hz	0.00 Hz	102
04-22	P.134	Programmed operation mode speed 4	0 ~ 650.00Hz	0.00 Hz	102
04-23	P.135	Programmed operation mode speed 5	0 ~ 650.00Hz	0.00 Hz	102
04-24	P.136	Programmed operation mode speed 6	0 ~ 650.00Hz	0.00 Hz	102
04-25	P.137	Programmed operation mode speed 7	0 ~ 650.00Hz	0.00 Hz	102
04-26	P.138	Programmed operation mode speed 8	0 ~ 650.00Hz	0.00 Hz	102

Appendix 1 Parameter table

Group	Parameter Number	Name	Setting Range	Default	Page
04-27	P.101	Programmed operation mode speed 1 operating time	0 ~ 6000.0s	0.0s	102
04-28	P.102	Programmed operation mode speed 2 operating time	0 ~ 6000.0s	0.0s	102
04-29	P.103	Programmed operation mode speed 3 operating time	0 ~ 6000.0s	0.0s	102
04-30	P.104	Programmed operation mode speed 4 operating time	0 ~ 6000.0s	0.0s	102
04-31	P.105	Programmed operation mode speed 5 operating time	0 ~ 6000.0s	0.0s	102
04-32	P.106	Programmed operation mode speed 6 operating time	0 ~ 6000.0s	0.0s	102
04-33	P.107	Programmed operation mode speed 7 operating time	0 ~ 6000.0s	0.0s	102
04-34	P.108	Programmed operation mode speed 8 operating time	0 ~ 6000.0s	0.0s	103
04-35	P.111	Programmed operation mode speed 1 Acc/Dec time	0 ~ 600.00s/0 ~ 6000.0s	0.00s	103
04-36	P.112	Programmed operation mode speed 2 Acc/Dec time	0 ~ 600.00s/0 ~ 6000.0s	0.00s	103
04-37	P.113	Programmed operation mode speed 3 Acc/Dec time	0 ~ 600.00s/0 ~ 6000.0s	0.00s	103
04-38	P.114	Programmed operation mode speed 4 Acc/Dec time	0 ~ 600.00s/0 ~ 6000.0s	0.00s	103
04-39	P.115	Programmed operation mode speed 5 Acc/Dec time	0 ~ 600.00s/0 ~ 6000.0s	0.00s	103
04-40	P.116	Programmed operation mode speed 6 Acc/Dec time	0 ~ 600.00s/0 ~ 6000.0s	0.00s	103
04-41	P.117	Programmed operation mode speed 7 Acc/Dec time	0 ~ 600.00s/0 ~ 6000.0s	0.00s	103
04-42	P.118	Programmed operation mode speed 8 Acc/Dec time	0 ~ 600.00s/0 ~ 6000.0s	0.00s	102
05-00	P.301	Motor specifications automatic measurement	0: Off	0	105
			1: Induction motor specifications automatic measurement (Run motor to measure)		
			2: Induction motor specifications automatic measurement (Don't run motor to measure)		
			3: Induction motor specifications automatic measurement (Measure when operating)		
05-01	P.302	Motor rated power	0 ~ 160.00kW	0.00kW	107
05-02	P.303	Motor poles	0 ~ 256	4	107
05-03	P.304	Motor rated voltage	0 ~ 510V	380V/440V	107
				220V	
05-04	P.305	Motor rated frequency	50Hz system : 0 ~ 650.00Hz	50.00Hz	107
			60Hz system : 0 ~ 650.00Hz	60.00Hz	

Appendix 1 Parameter table

Group	Parameter Number	Name	Setting Range	Default	Page
05-05	P.306	Motor rated current	0~500.0A	According to kw	107
05-06	P.307	Motor rated rotation speed	50Hz system : 0 ~ 65000r/min	1410r/min	107
			60Hz system : 0 ~ 65000r/min	1710r/min	
05-07	P.308	IM Motor excitation current	0~500.00A	According to kw	107
05-08	P.309	IM motor stator resistance	0 ~ 99.98Ω :	According to kw	107
06-00	P.9	Electronic thermal relay capacity	0~500.00A	0.00A	110
06-01	P.22	Stall prevention operation level	0 ~ 250.0%	150.0%	111
06-02	P.23	Stall prevention operation level correction factor	0 ~ 200.0%	99999	111
			99999: Stall prevention operation level is the setting value of 06-01(P.22).		
06-03	P.66	Stall prevention operation reduction starting frequency	50Hz system:0 ~ 650.00Hz	50.00Hz	111
			60Hz system:0 ~ 650.00Hz	60.00Hz	
06-05	P.30	Regenerative brake selection	0: Brake duty is fixed at 3%, parameter 06-06(P.70) will be off.	0	112
			1: Brake duty is 06-06(P.70) value.		
06-06	P.70	Special regenerative brake duty	0 ~ 100.0%	0.0%	112
06-08	P.155	Over torque detection level	0 ~ 200.0%	0.0%	113
06-09	P.156	Over torque detection time	0 ~ 60.0s	1.0s	113
06-10	P.260	Action when detect over torque	0: OL2 alarm will not be reported after over torque detection, and inverter keeps running.	1	113
			1: OL2 alarm will be reported after over torque detection, and inverter stops.		
06-12	P.245	Cooling fan working mode	0 : When running turn on the fan, after stop for 30 seconds turn off the fan.	1	114
			1 :When power on turn on the fan, after power off turn off the fan.		
			2 : When running and the heat sink temperature exceeds 60°C turn on the fan, under 40°C turn off the fan.		
			3 :When the heat sink temperature exceeds 60°C turn on the fan, under 40°C turn off the fan.		
06-13	P.281	Input phase loss protection	0: Off	0	114
			1: When input phase loss, built-in keypad shows IPF alarm and inverter stops		
06-17	P.261	Maintenance alarm function	0: Off	0	114
			1 ~ 9998day: Used to set the time for maintenance alarm output signal		

Appendix 1 Parameter table

Group	Parameter Number	Name	Setting Range	Default	Page
06-18	P.280	Short circuit to ground protection function when start	XX0 : Off	0	114
			XX1 : Detect leakage current of ground when inverter starts		
			0X1 : Detect leakage current of ground only for the first startup		
			1X1 : Detect leakage current of ground for every startup.		
06-19	P.282	GF detection level when operating	0 ~ 100%	50%	114
06-27	P.292	Total inverter operation time (minutes)	0 ~ 1439 min	0min	115
06-28	P.293	Total inverter operation time (days)	0 ~ 9999 day	0day	115
06-29	P.296	Total inverter power on time (minutes)	0 ~ 1439 min	0min	115
06-30	P.297	Total inverter power on time (days)	0 ~ 9999 day	0day	115
06-40	P.288	Alarm record code query	Choose 0 ~ 12 recorded alarm	0	116
06-41	P.289	Alarm record code display	Read only	Read only	116
06-42	P.290	Alarm record message query	Choose 0 ~ 10 recorded alarm	0	116
06-43	P.291	Alarm record message display	Read only	Read only	116
06-84	P.207	Fire mode	XXX0:Invalid(the fire mode is forbidden(normal mode))	0	117
			XXX1:Forward operation(the inverter runs forward in fire mode)		
			XXX2:Reverse operation(the inverter runs reversely in fire mode)		
			0XXX:Manually exit fire mode 1 (if the start fire mode terminal is OFF, the inverter need reset manually and back to normal mode)		
			1XXX:Exit fire mode automatically (if the start fire mode terminal is OFF, the inverter goes to normal mode automatically)		
			2XXX:Manually exit fire mode 2(if the start fire mode terminal is OFF, the inverter keeps running, need reset manually and back to normal mode)		
06-85	P.208	Frequency setting in fire mode	0~650.00Hz	60.00Hz	117
06-88	P.209	Accumulated times in fire mode	Read only	Read only	117
07-00	P.33	Communication protocol selection	0 : Modbus protocol	1	120
			1 : Shihlin protocol		
07-01	P.36	Inverter communication station number	0 ~ 254	0	120

Group	Parameter Number	Name	Setting Range	Default	Page
07-02	P.32	Serial communication baud rate	0 : baud rate :4800bps	1	120
			1 : baud rate :9600bps		
			2 : baud rate :19200bps		
			3 : baud rate :38400bps		
			4 : baud rate :57600bps		
			5 : baud rate :115200bps		
07-03	P.48	Data length	0 : 8bit	0	120
			1 : 7bit		
07-04	P.49	Stop bit length	0 : 1bit	0	120
			1 : 2bit		
07-05	P.50	Parity check selection	0 : No parity check	0	120
			1 : Odd		
			2 : Even		
07-06	P.51	CR/LF selection	1: CR only	1	120
			2 : Both CR and LF		
07-07	P.154	Modbus communication format	0 : 1、7、N、2 (Modbus, ASCII)	4	120
			1 : 1、7、E、1 (Modbus, ASCII)		
			2 : 1、7、O、1 (Modbus, ASCII)		
			3 : 1、8、N、2 (Modbus, RTU)		
			4 : 1、8、E、1 (Modbus, RTU)		
			5 : 1、8、O、1 (Modbus, RTU)		
6 : 1、8、N、1 (Modbus, RTU)					
07-08	P.52	Number of communication retries	0 ~ 1000	5	120
07-09	P.53	Communication interval allowed time	0 ~ 999.8s : Check communication timeout with the set value	99999	120
			99999 : No timeout check		
07-10	P.153	Communication alarm action	0 : Alarm and stop freely	0	120
			1 : No alarm and continuing to operation		
07-11	P.34	Communication EEPROM write-in selection	0 : When writing parameters through communication, write in RAM and EEPROM	0	135
			1 : When writing parameters through communication, only write into RAM		
08-00	P.170	PID function selection	0: Off	0	137
			2 : Parameter 08-03(P.225) as target value, terminal 3-5 current/voltage input as feedback source		
			3 : Target value is set by multi-speed value, and feedback from terminal 3-5 current/voltage input		
08-01	P.171	PID feedback control method	0: Negative feedback control.	0	137
			1: Positive feedback control.		
08-03	P.225	PID target value from keypad	0 ~ 08-43(P.251)	20.0%	137
08-04	P.172	Proportional gain	1~100	20	137
08-05	P.173	Integral time	0 ~ 100.0s	1.0s	137

Appendix 1 Parameter table

Group	Parameter Number	Name	Setting Range	Default	Page
08-06	P.174	Differential time	0 ~ 1000ms	0ms	137
08-07	P.175	Abnormal deviation	0 ~ 200.0%	0.0%	137
08-08	P.176	Abnormal duration time	0 ~ 600.0s	30.0s	137
08-09	P.177	Abnormal processing mode	0: Stop freely	0	137
			1: Slow down to stop		
			2: Alarm and continue operation		
08-10	P.178	Sleep detection deviation	0 ~ 100.0%	0.0%	137
08-11	P.179	Sleep detection duration time	0 ~ 255.0s	1.0s	138
08-12	P.180	Wake-up level	0 ~ 200.0%	90.0%	138
08-13	P.181	Stop level	0 ~ 120.00Hz	40.00Hz	138
08-14	P.182	Upper integral limit	50Hz system:0 ~ 120.00Hz	50.00Hz	138
			60Hz system:0 ~ 120.00Hz	60.00Hz	
08-15	P.183	Deceleration step length when stable	0 ~ 10.00Hz	0.50Hz	138
08-18	P.223	Analog feedback signal bias	0 ~ 100.0%	0.0%	138
08-19	P.224	Analog feedback signal gain	0 ~ 100.0%	100.0%	138
08-43	P.251	PID pressure range (Bar) setting	1.0~100.0	100.0	141
08-45	P.253	Analog signal feedback loss detection time	0.0~600.0s	0.0s	141
08-46	P.254	Analog signal feedback loss action selection	0 : Alarm AErr and inverter stop freely	0	141
			1 : Slow down to stop then alarm AErr		
			2 : Alarm AErr and continue operation		
10-00	P.10	DC brake operating frequency	0 ~ 120.00Hz	3.00Hz	144
10-01	P.11	DC brake operating time	0 ~ 60.0s	0.5s	144
10-02	P.12	DC brake operating voltage	7.5K/11KF and below model : 0 ~ 30.0%	4.0%	144
			11K/15KF and above model : 0 ~ 30.0%	2.0%	
10-03	P.151	Zero-speed control function selection	0: Off.	0	145
			1: DC voltage braking		
10-04	P.152	Voltage at zero-speed control	7.5K/11KF and below model : 0 ~ 30.0%	5.0%	145
			11K/15KF and above model : 0 ~ 30.0%	2.0%	
10-05	P.242	DC brake before inverter start	0: Off	0	145
			1: Before starting operate DC brake first.		
10-06	P.243	DC brake time before inverter start	0 ~ 60.0s	0.5s	145
10-07	P.244	DC brake voltage before inverter start	7.5K/11KF and below model : 0 ~ 30.0%	4.0%	145
			11K/15KF and above model : 0 ~ 30.0%	2.0%	
10-08	P.150	Restart mode selection	X0 : No frequency search.	0	146
			X1 : Reserved		
			X2 : Decrease voltage mode		
			0X : Power on once.		
			1X : Start each time.		
			2X : Only instantaneous stop and restart		
3X : Only valid when the inverter resets in fire mode					

Group	Parameter Number	Name	Setting Range	Default	Page
10-09	P.57	Restart idling time	0 ~ 30.0s	99999	146
			99999: Off.		
10-10	P.58	Restart rising time	7.5K/11KF and below model : 0 ~ 60.0s	5.0s	146
			11K/15KF and above model : 0 ~ 60.0s	10.0s	
10-11	P.61	Remote control function	0: Off	0	147
			X1 : Remote control function, frequency save in memory		
			X2 : Remote control function, frequency won't save		
			X3 : Remote control function, frequency won't save, clear frequency setting every time STF/STR "turn off".		
			X4: Remote control function, frequency save in memory every 5s		
			1X:Frequency command range 01-01(P.2)~01-00 (P.1), frequency command value from RH,RM setting		
10-12	P.65	Auto reset function	0: Off.	0	149
			1: When over-voltage, inverter will reset.		
			2: When over-current, inverter will reset.		
			3: When either over-voltage or over-current, inverter will reset.		
			4: When any alarm occurs, inverter will reset.		
10-13	P.67	Auto reset times	0: Off.	0	149
			1 ~ 10: If the alarm exceeds 10-13(P.67) times, inverter will not reset.		
10-14	P.68	Auto reset waiting time	0 ~ 360.0s	6.0s	149
10-15	P.69	Auto reset times count	Read only	0	149
10-16	P.119	Forward and reverse rotation dead time	0 ~ 3000.0s	0.0s	150
10-17	P.159	Energy-saving control function	0: Off.	0	150
			1: Energy-saving mode.		
10-18	P.229	Dwell function selection	0: Off.	0	151
			1: Backlash compensation function.		
			2: Acceleration and deceleration interrupt waiting function.		
10-19	P.230	Dwell frequency at acceleration	0 ~ 650.00Hz	1.00Hz	151
10-20	P.231	Dwell time at acceleration	0 ~ 360.0s	0.5s	151
10-21	P.232	Dwell frequency at deceleration	0 ~ 650.00Hz	1.00Hz	151
10-22	P.233	Dwell time at deceleration	0 ~ 360.0s	0.5s	151
10-23	P.234	Triangular wave function selection	0: Off.	0	152
			1: If terminal function TRI is triggered, triangular wave function will on.		
			2: Triangular wave function is on at all time.		
10-24	P.235	Maximum amplitude	0 ~ 25.0%	10.0%	152
10-25	P.236	Amplitude compensation at deceleration	0 ~ 50.0%	10.0%	152
10-26	P.237	Amplitude compensation at acceleration	0 ~ 50.0%	10.0%	152

Appendix 1 Parameter table

Group	Parameter Number	Name	Setting Range	Default	Page
10-27	P.238	Amplitude acceleration time	0 ~ 360.00s/0 ~ 3600.0s	10.00s	152
10-28	P.239	Amplitude deceleration time	0 ~ 360.00s/0 ~ 3600.0s	10.00s	152
10-46	P.268	Voltage stall level	220V : 155 ~ 410V	380V	153
			440V : 310 ~ 820V	760V	
10-55	P.226	Reciprocating machine function selection	0 : Off	0	153
			1 : Turn on reciprocating machine function		
10-56	P.227	Reciprocating forward limit time	0~3600.0s	0.0s	153
10-57	P.228	Reciprocating reverse limit time	0~3600.0s	0.0s	153
11-00	P.320	Slip compensation gain	0~200%	85%	155
11-01	P.321	Torque boost filter coefficient	0 ~ 2000	20	155
11-02	P.322	Cutoff frequency point of current filter time 1	0~30.00Hz	4.00Hz	155
11-03	P.323	Current filter time 1	0~400.00ms	According to kw	155
11-04	P.324	Low frequency current filter time 2	0~400.00ms	According to kw	155
11-05	P.325	High frequency current filter time 2	0~400.00ms	According to kw	155
13-00	P.89	Slip compensation coefficient	0 ~ 10	0	156
13-03	P.286	High frequency vibration suppression factor	0.2K~5.5K model : 0 ~ 1515	300	156
			7.5K/11KF and above : 0 ~ 1515	509	
15-00	P.900	User registered parameter 1	P parameter mode: 0~399 Parameter group mode: 00-00~13-99	99999	158
15-01	P.901	User registered parameter 2		99999	158
15-02	P.902	User registered parameter 3		99999	158
15-03	P.903	User registered parameter 4		99999	158
15-04	P.904	User registered parameter 5		99999	158
15-05	P.905	User registered parameter 6		99999	158
15-06	P.906	User registered parameter 7		99999	158
15-07	P.907	User registered parameter 8		99999	158
15-08	P.908	User registered parameter 9		99999	158
15-09	P.909	User registered parameter 10		99999	158
15-10	P.910	User registered parameter 11		99999	158
15-11	P.911	User registered parameter 12		99999	158
15-12	P.912	User registered parameter 13		99999	158
15-13	P.913	User registered parameter 14		99999	158
15-14	P.914	User registered parameter 15		99999	158
15-15	P.915	User registered parameter 16		99999	158
15-16	P.916	User registered parameter 17		99999	158
15-17	P.917	User registered parameter 18		99999	158
15-18	P.918	User registered parameter 19		99999	158
15-19	P.919	User registered parameter 20		99999	158

7.2 Appendix 2 Alarm code list

Code	Keypad screen display	Cause	Troubleshooting
ERROR	Error	<ol style="list-style-type: none"> 1.Low input voltage. 2.The reset function "RES" is on. 3.Bad connection between the external keypad and main body. 4.Internal circuit malfunction. 5. CPU error. 6. Abnormal insulation of load to ground. 	<ol style="list-style-type: none"> 1.Use a better power supply. 2.Shut off "RES". 3.Ensure the keypad is connected firmly. 4.Replace the inverter. 5.Restart the inverter. 6. Check the insulation of the motor cable and the three-phase winding of the motor.
OC0 Over-current at startup	OC0		<ol style="list-style-type: none"> 1.Check whether the insulation layer of the motor power line is damaged 2.Check whether a contactor is used in series on the output side of the inverter, the contactor's contacts will arc and leads to inverter detects overcurrent (please avoid this usage, please refer to manual for wiring details) 3.The control circuit of the inverter is interfered with external noise (for example: the electromagnetic contactor frequently switches to power supply load), it is recommended to add magnetic rings on output line of the electromagnetic contactor, and add magnetic ring with 2~3 windings on control terminal input signal on inverter 4.If alarm OC0 when the motor is disconnected, it needs to be sent to the factory for inspection
OC1 Over-current during acceleration	OC1	The output current is two times larger than the rated current of the inverter or the output side is short.	<ol style="list-style-type: none"> 1.It is recommended to increase the acceleration time P.7 (01-06) 2.Check the insulation condition of the motor power line (for example: the insulation of the three-phase motor is short to ground, the power line is short-circuited, or short circuit between power line and the metal part of the electric cabinet) 3.Check whether the base frequency parameter P.3 (01-03) of the inverter is the same with the rated frequency of the motor
OC2 Over-current at constant speed	OC2		<ol style="list-style-type: none"> 1.It is recommended to reduce the load to eliminate motor stall and transmission mechanism jam 2.Check the insulation condition of the motor power line (for example: the insulation of the three-phase motor is short to ground, the power line is short-circuited, or short circuit between power line and the metal part of the electric cabinet) 3.Check whether the selection of the inverter power is too low

Appendix 2 Alarm code list

Code	Keypad screen display	Cause	Troubleshooting
OC3 Over-current during deceleration	OC3	The output current is two times larger than the rated current of the inverter or the output side is short.	<ol style="list-style-type: none"> 1.It is recommended to increase the deceleration time P.8 (01-07) 2.It is recommended to set the base voltage parameter P.19 (01-04) equal to power supply voltage 3.It is recommended to add braking unit and braking resistor
OV0 Over-voltage at startup	OV0	<ol style="list-style-type: none"> 1. The voltage between DC bus is too high. 2. The external power supply line has large power equipment start and stop affecting the power grid surge. 	<ol style="list-style-type: none"> 1.Check whether the input power voltage is abnormal 2.Check whether the motor is grounded (if so, it is recommended to remove the ground wire after turning off the power) 3.Check the insulation condition of the motor power line (for example: the insulation of the three-phase motor is short to ground, the power line is short-circuited, or short circuit between power line and the metal part of the electric cabinet)
OV1 Over-voltage during acceleration	OV1		<ol style="list-style-type: none"> 1.Check whether the input power voltage is abnormal 2.Check whether the motor is grounded (if so, it is recommended to remove the ground wire after turning off the power) 3.Check the insulation condition of the motor power line (for example: the insulation of the three-phase motor is short to ground, the power line is short-circuited, or short circuit between power line and the metal part of the electric cabinet)
OV2 Over-voltage at constant speed	OV2		<ol style="list-style-type: none"> 1.Check whether the input power voltage is abnormal 2.Check whether the motor is grounded (if so, it is recommended to remove the ground wire after turning off the power) 3.It is recommended to add an input AC reactor at the input end of the inverter 4.Check the insulation condition of the motor power line (for example: the insulation of the three-phase motor is short to ground, the power line is short-circuited, or short circuit between power line and the metal part of the electric cabinet)
OV3 Over-voltage during deceleration	OV3		<ol style="list-style-type: none"> 1.It is recommended to increase the deceleration time P.8 (01-07) 2.It is recommended to add braking unit and braking resistor 3.Set the base voltage parameter P.19 (01-04) to 99999 4.Check the insulation condition of the motor power line (for example: the insulation of the three-phase motor is short to ground, the power line is short-circuited, or short circuit between power line and the metal part of the electric cabinet)

Code	Keypad screen display	Cause	Troubleshooting
THT IGBT module Overheat	THT	<ol style="list-style-type: none"> 1. IGBT module thermal relay actuate. (overload warning) 2. 01-03 (P.3) setting does not match the rated frequency of the motor. 3. Insufficient input power voltage causes inverter output capacity reduced. 4. The three phase input connection of the motor is incorrect. 	<ol style="list-style-type: none"> 1. Check whether the inverter specifications match the motor specifications 2. Check whether the load of the system is too heavy, and whether the output current displayed by the inverter exceeds the rated current 3. Check whether the wiring of the motor is correct (usually 220V motor is delta (Δ) connection, 380V motor is star (Y) connection, please check motor nameplate for connection details) 4. Check whether the motor wiring is damaged 5. Check whether the setting value of P.9 (06-00) matches the rated current of the motor 6. Check whether the parameter setting of P.3 (01-03) is the same with the rated frequency of the motor
THN Motor Overheated	THN	Thermal relay actuate.	<ol style="list-style-type: none"> 1. Check whether the inverter specifications match the motor specifications 2. Check whether the load of the system is too heavy, and whether the output current displayed by the inverter exceeds the rated current 3. Check whether the wiring of the motor is correct (usually 220V motor is delta (Δ) connection, 380V motor is star (Y) connection, please check motor nameplate for connection details) 4. Check whether the motor wiring is damaged 5. Check whether the setting value of P.9 (06-00) matches the rated current of the motor 6. Check whether the parameter setting of P.3 (01-03) is the same with the rated frequency of the motor
OHT External Overheat	OHT	External thermal relay actuate.	<ol style="list-style-type: none"> 1. Check if the thermal relay used matches the motor 2. Reduce the load 3. Check if the external IO signal is not connected or dropped
OPT RS485 connector error	OPT	<ol style="list-style-type: none"> 1. Communication error , exceeding the retry limit. 2. External noise interference 3. The logic of the communication control program is unreasonable 4. Disconnect time exceeding the limit. 	<ol style="list-style-type: none"> 1. Check whether the parameter (P.32, P.33, P.36, P.154) setting is the same with upper controller communication setting 2. Check whether the RS485 DA+ and DB-terminal wiring is correctly connected to the upper controller 3. Check whether the communication protocol of the upper controller is the same as the one declared in inverter 4. The communication line is interfered by external noise (it is recommended to use twisted-pair shielded wire and connect to the signal ground correctly) 5. The inverter internal communication port is damaged and needs to be returned to the factory for inspection

Appendix 2 Alarm code list

Code	Keypad screen display	Cause	Troubleshooting
EEP Memory error	EEP	ROM malfunction	If the alarm repeated, send the unit back to the dealer or the manufacturer to repair. Avoid frequent parameters modification and saving target frequency to EEPROM, please refer to 07-11 (P.34) and target frequency address H1002 to prevent damage.
PIDE PID error	PIDE	1.The capacity of the inverter or motor is not enough 2.PID target value or feedback value doesn't make sense 3.Peripheral devices malfunction 4. During PID control, the feedback signal is not connected or dropped	1.Use an inverter or a motor with bigger capacity. 2.Check PID parameters 3.Check all peripheral feedback devices of the system (sensors, potentiometer) and wirings.
CPU CPU error	CPU	Strong electromagnetic interference	Reduce peripheral interference.
OLS Stall prevention and protection	OLS	Over-loaded motor	1.Reduce the load 2.Increase 06-01(P.22) value.
NTC Module overheat	NTC	The inverting part of IGBT module overheated	1.Lower the surrounding temperature and increase venting 2. Check if the cooling fan is functioning properly 3. Confirm whether the carrier frequency 00-11 (P.72) is set too large
IPF Input power error	IPF	Input power error(phase loss)	Check if the power supply is normal.
OL2 Torque overload	OL2	1. Motor overload 2. The value in 06-08 (P.155) and 06-09(P.156) doesn't make sense.	1.Reduce the load 2.Set 06-08 (P.155) and 06-09(P.156) properly
CPR CPU error	CPR	CPU error	1.Check the wiring 2.Check the parameter setup 3.Reduce noise interference
AErr Terminal 3-5 error	AErr	The terminal 3-5 analog input disconnect	check 3-5 terminal cable connection status
GF Output short to ground	GF	Shortage between output and ground	Please check whether the motor short circuit to ground

Note 1: Do not turn on the power repeatedly before removing the cause of the alarm.

7.3 Appendix 3 : Warning code list

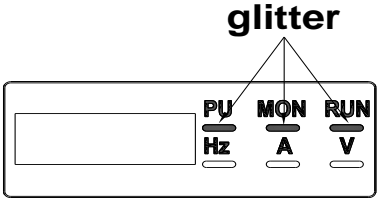
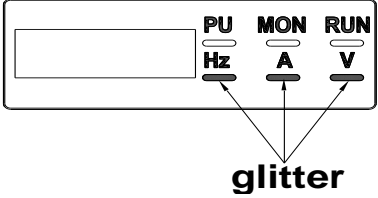
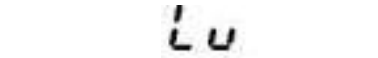
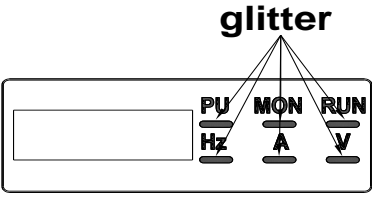
Code	Built-in keypad status	Reason	Action
Current stall		When the output current is greater than the stall level, the three small lights at the top right of the built-in keypad will flash, indicating that the inverter is currently in a current stall state, and the motor will not run smoothly.	<ol style="list-style-type: none"> 1. Check whether the setting of 06-01 (P.22), 06-02 (P.23), 06-03 (P.66) is reasonable; 2. Check whether the set value of 01-06 (P.7), 01-07 (P.8) is too small;
Voltage stall		If the DC bus voltage is too high, inverter will be in a voltage stall state, and the three small lights at the bottom right of the built-in keypad will flash, and the motor will not run smoothly.	<ol style="list-style-type: none"> 1. Add a regenerative braking resistor between the main circuit terminals P and PR ; 2. Check whether the set value of 01-06 (P.7), 01-07 (P.8) is too small
LV Undervoltage		Input voltage is too low	Supply normal voltage.
LT action		When the inverter output current is higher than twice the rated current, but does not reach the overcurrent level, the six small lights on the right side of the built-in keypad will flash, indicating that the inverter is now in LT state, and the motor will not run smoothly.	<ol style="list-style-type: none"> 1. If there is rapid acceleration or rapid deceleration, please extend the acceleration and deceleration time 2. Avoid sudden increase in load 3. Check whether there is a short circuit at the motor terminal U/T1-V/T2-W/T3

Note: The function of the above warning is to inform the customer of the current working condition of the inverter. The inverter will not stop. Please adjust the parameter value appropriately or confirm the power supply and load status.

7.4 Appendix 4:Troubles and solutions

Troubles	Check points	
The motor does not run	Main circuit	<ul style="list-style-type: none"> •Is the voltage between terminals R/L1-S/L2-T/L3 normal? •Is the wiring between the inverter and the motor correct?
	Load	<ul style="list-style-type: none"> •Is the load too heavy? •Is the motor rotor locked?
	Parameters Setting	<ul style="list-style-type: none"> •Is the startup frequency (01-11(P.13)) set too high? •Is the operation mode (00-16(P.79)) correct? •Is the upper limit frequency (01-00(P.1)) set to zero? •Is forward reverse rotation prevention (00-15(P.78)) limited? •Is the signal input and percentage setting (02-25 (P.198) ~02-28 (P.197)) correct? •Is the frequency jump (01-16(P.91)~01-21(P.96)) correct?
	Control circuit	<ul style="list-style-type: none"> •Is MRS function “on”? (relevant parameters 03-00(P.83), 03-01(P.84), 03-03(P.80) , 03-04(P.81)) •Is RES function “on”? (relevant parameters 03-00(P.83) 、 03-01(P.84) 、 03-03(P.80)、 03-04(P.81)) •Is the external thermal relay tripping? •Is there an alarm that has not been reset? •Is the voltage/current signal properly connected? • Are STF and STR functions correct? (relevant parameters 03-00(P.83), 03-01(P.84), 03-03(P.80), 03-04(P.81)) •Does the wiring of the control circuit fall off or have poor contact?
Opposite motor rotation direction	<ul style="list-style-type: none"> •Is the phase sequence of the wiring of the motor terminal (U/T1)/(V/T2)/(W/T3) correct? •Is the wiring of the start terminals STF and STR correct? 	
The motor cannot accelerate	<ul style="list-style-type: none"> •Is the load too heavy? •Is stall prevention level (06-01(P.22)) correct? •Is torque compensation (01-10(P.0)) too high? •Is it limited by the upper limit frequency (01-00(P.1))? 	
Unsmooth acceleration and deceleration	<ul style="list-style-type: none"> •Is the acceleration and deceleration time (01-06(P.7) and 01-07(P.8)) set correctly? •Is the acceleration/deceleration curve selection (01-05(P.29)) correct? •Does the voltage/current signal fluctuate due to noise? 	
Excessive motor current	<ul style="list-style-type: none"> •Is the load too heavy? •Does the inverter capacity match the motor capacity? •Is torque compensation (01-10(P.0)) too high? 	
Speed fluctuation in operation	<ul style="list-style-type: none"> •Does the voltage/current signal fluctuate due to noise? •Has the motor load changed? •Is the main circuit wiring too long? 	

7.5 Appendix 5 Optional equipment

7.5.1 PU301 Keypad

➤ PU301 appearance

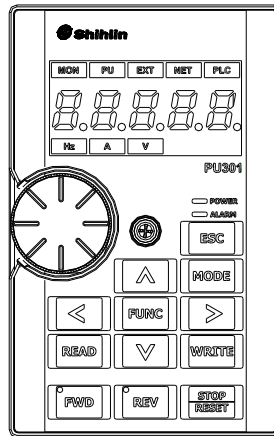

Order number

NO.	Model	Name	Order code
1	PU301	LED Keypad	SNKPU301

➤ Outline

<Outline drawing>

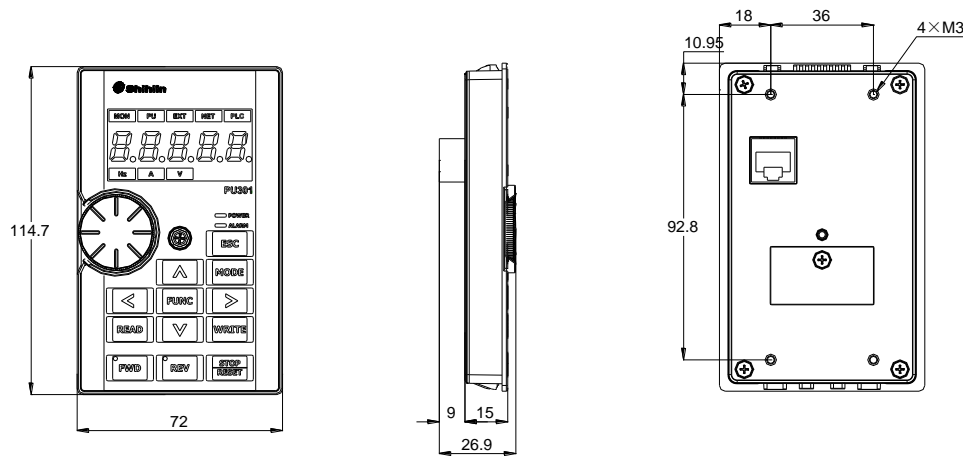

Appendix 5 Optional equipment

➤ Panel mounting hole size

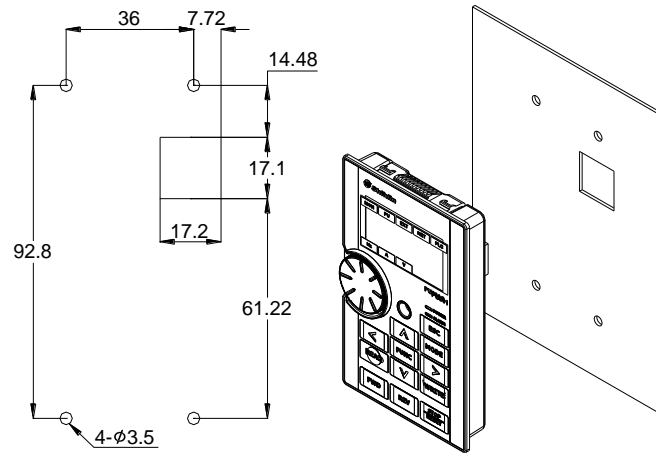

➤ Snap-in installation hole size

<Card buckle installation: panel cutting dimension drawing>

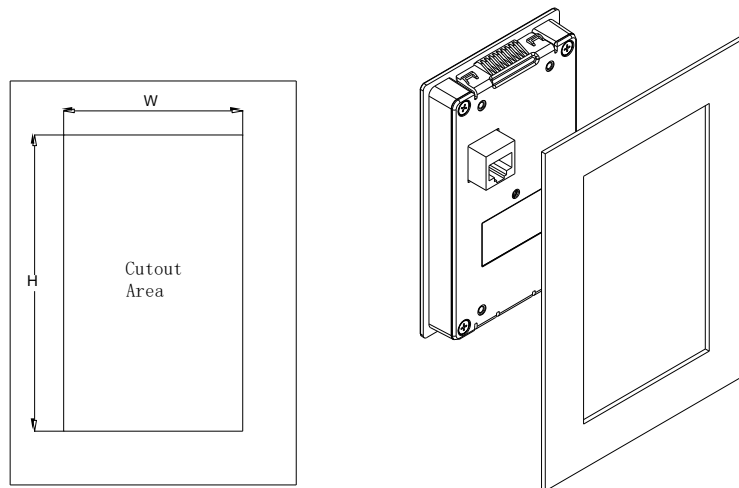

Panel thickness	1.2mm	1.6mm	2.0mm
W	66.4		
H	110.2	111.3	112.5

* Allowable error: $\pm 0.15\text{mm}$

* If the customer's drilling accuracy cannot meet the above allowable error, please purchase the accessory SMK301 (spring installation kit) for installation.

7.5.2 DU06 Keypad

➤ DU06 appearance

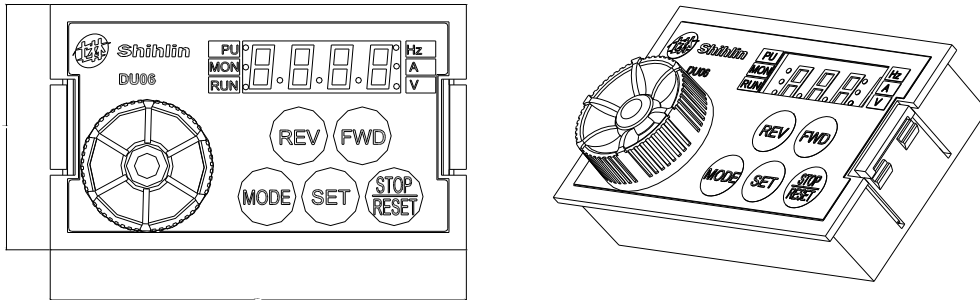

Order number:

NO.	Model	Name	Order code
1	DU06	DU06 keypad	SNKDU06

➤ DU06 dimension:

<Outline drawing>

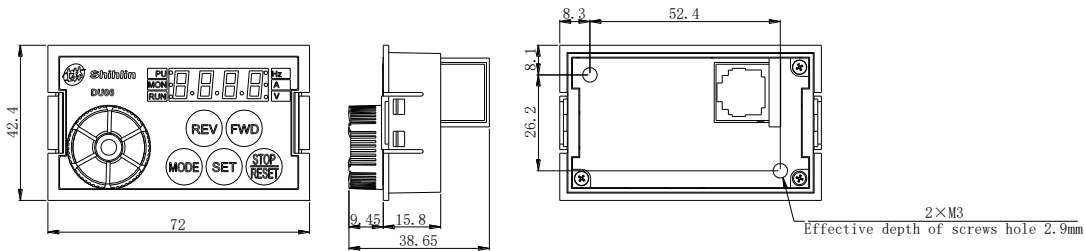

➤ DU06 Recommended screw installation size :

<Screw installation: panel cutting dimension drawing>

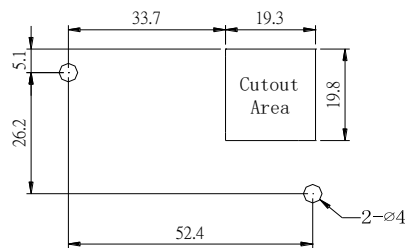

➤ DU06 Snap-in installation hole size:

<Snap-fit installation: panel cutting dimension drawing>

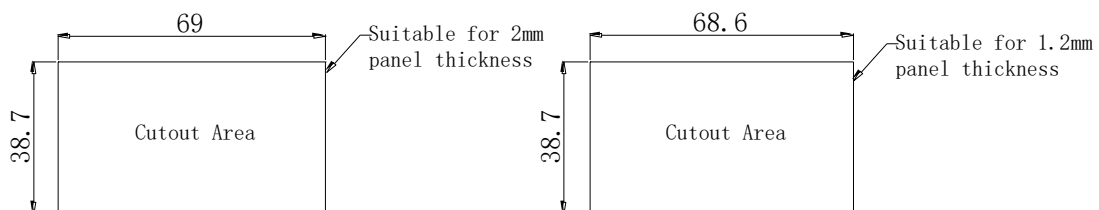

7.5.3 DU08 Keypad

DU08 appearance

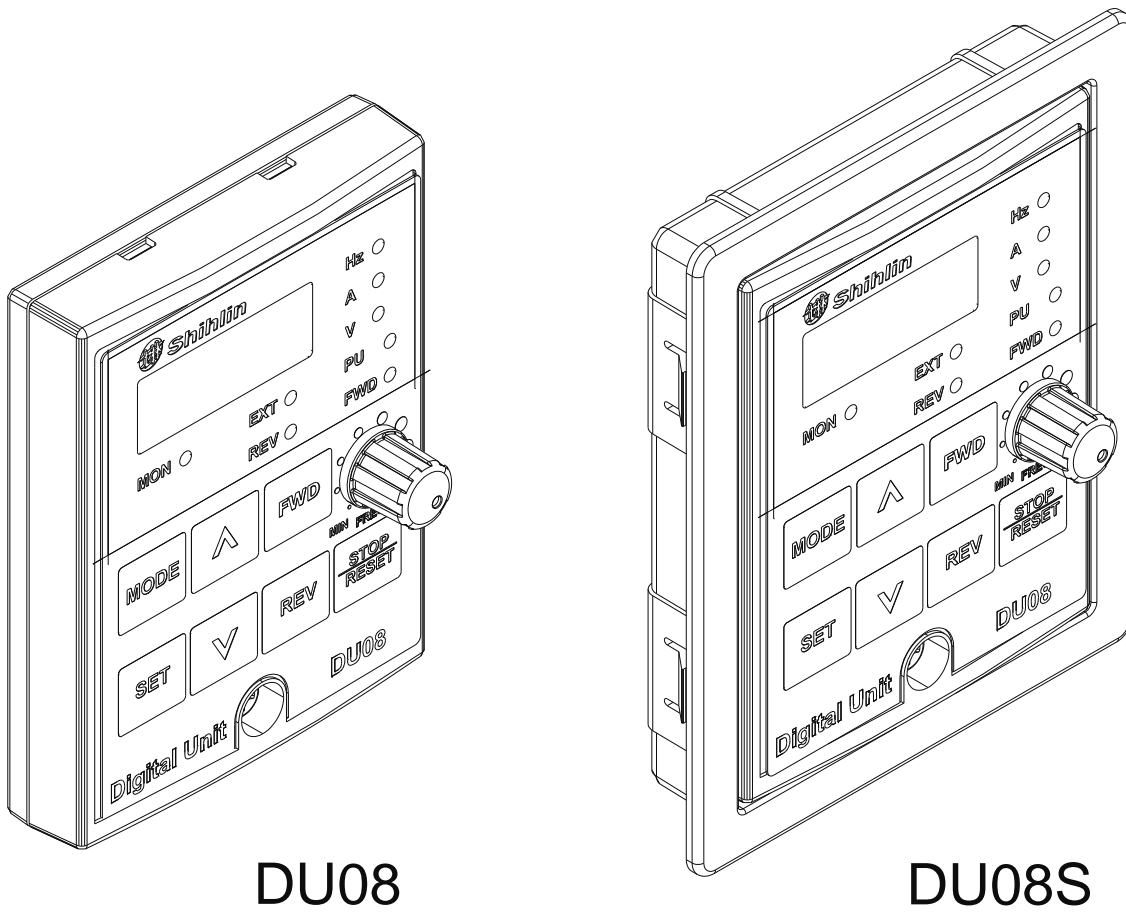

DU08

DU08S

Order number:

NO.	Model	Name	Order code
1	DU08	DU08 keypad	SNKDU08
2	DU08S	DU08S keypad	SNKDU08S

➤ DU08 outline:

<Outline dimensional drawing>

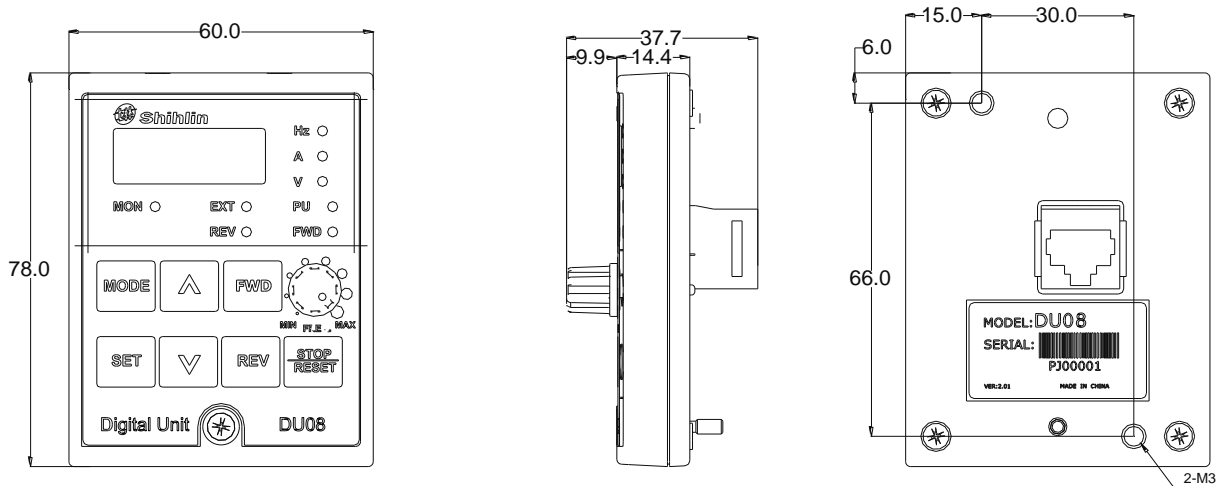

< Panel mounting hole size >< Flange mounting hole size >

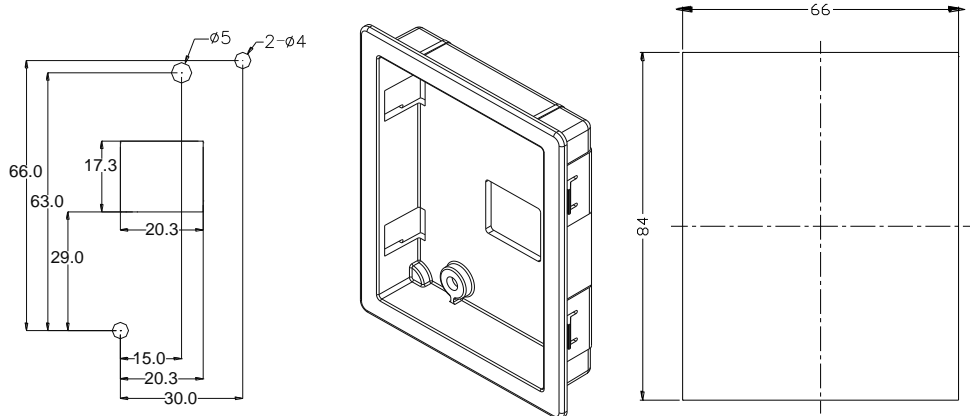

Note: For flange installation, the fixed installation base is not standard and needs to be purchased separately, order code: SNKDUMH02 (DU08S already includes this fixed installation base).

7.5.4 DU10 Keypad

DU10 appearance

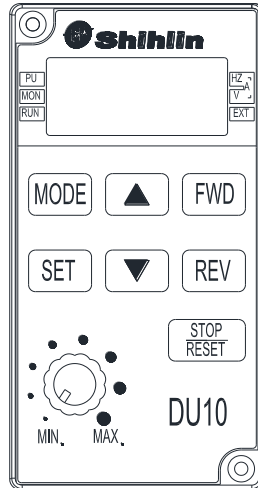

Order number:

NO.	Model	Name	Order code
1	DU10	DU10 keypad	SNKDU10

➤ DU10 outline:

< Outline drawing >

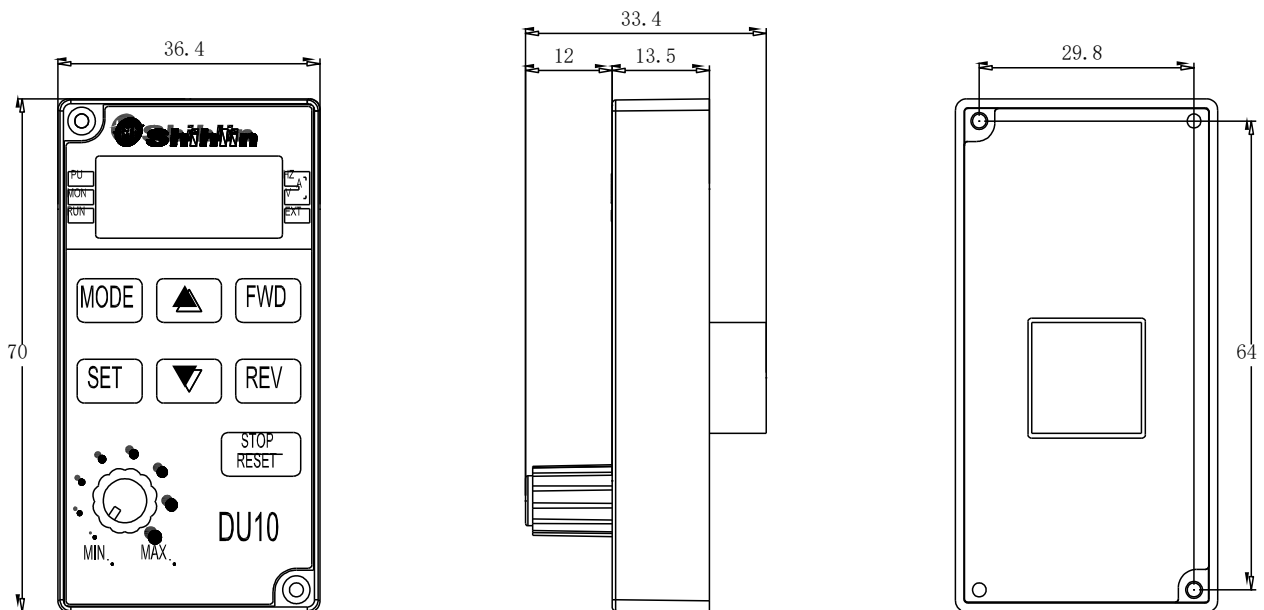

7.5.5 PU302 Keypad

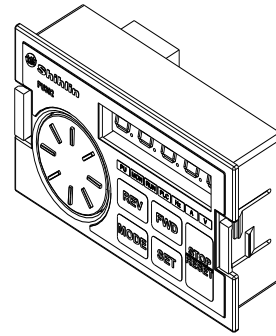
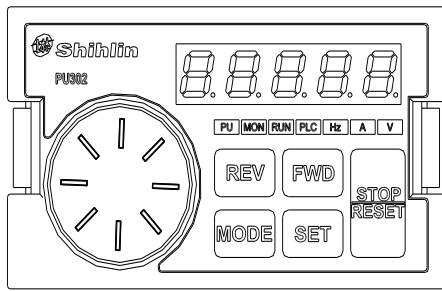

◆ Order number:

NO.	Model	Name	Order code
1	PU302	LED keypad	SNKPU302

◆ Outline

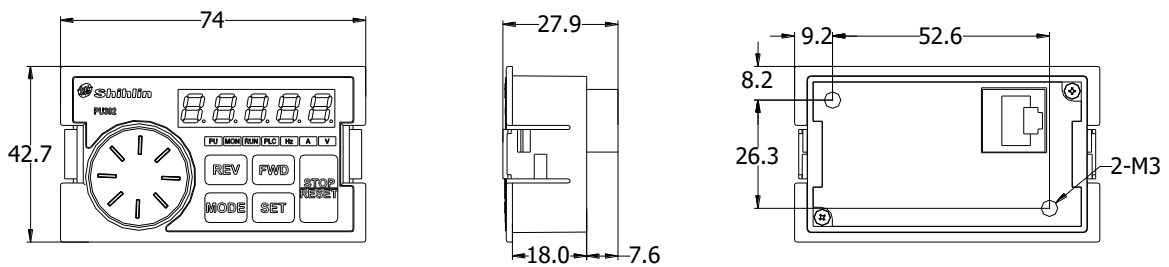

◆ Recommended screw installation size

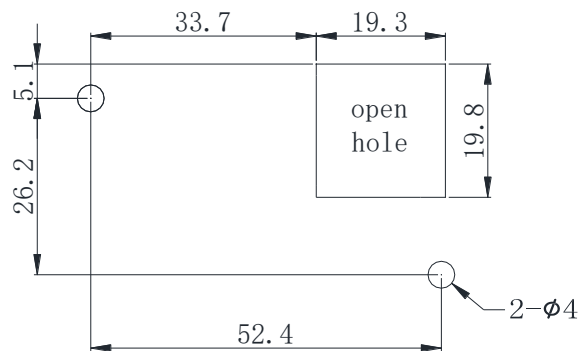

◆ Recommended installation size

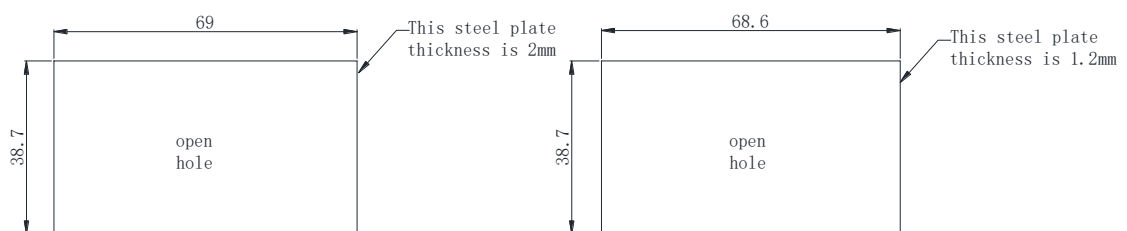

◆ Spring installation

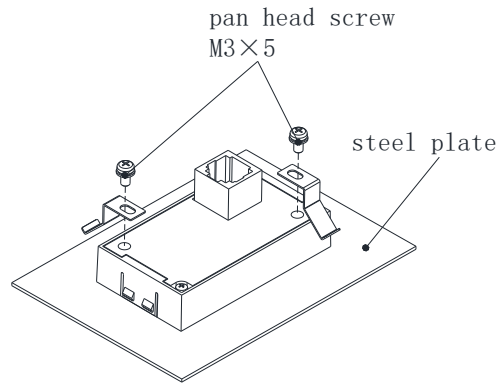

* Allowable error: $\pm 0.15\text{mm}$

* If the customer's drilling accuracy cannot meet the above tolerance, please purchase the accessory SMK301 (spring installation kit) for installation.

7.5.6 CBL : Data transmission line (for use with the above keypads)

Model: SNKCBLxxGTN2 (xx means 1R5,3,5,10)

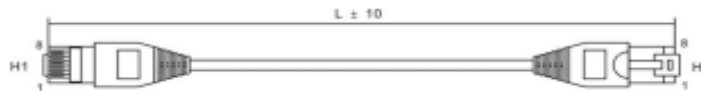

Item NO.	Part No.	L(mm)
1	SNKCBL1R5GTN2	1500
2	SNKCBL3GTN2	3000
3	SNKCBL5GTN2	5000
4	SNKCBL10GTN2	10000

7.6 Appendix 6 European Specification Compatibility Description

This inverter qualifies the CE label. Specifications:

Low Voltage Directive 2014/35/EU & Electromagnetic Compatibility Directive 2014/30/EU

1. Electromagnetic compatibility command (EMC):

(1). EMC compatibility description:

For system integration, inverter is not a functionally independent device unit. It is usually a unit in the control box. It is combined with other devices to control a machine or equipment. Therefore, our company does not consider that all the EMC commands should be directly applied on the inverter. As a result, the CE label of this inverter is not extensible.。

(2). Compatibility:

The inverter does not need to cover all the EMC commands. Yet, for certain machine equipment that needs to use EMC commands and the inverter, the machine has to be equipped with CE label. In addition, the company can provide the electromagnetic inspection data and operation manual that covers the required electromagnetic compatibility specifications for a quick and easy installation of the machine equipment of this inverter.

(3). Installation outline:

Please follow the following notes for installing the inverter:

*Use a noise filter qualifying the EU standard to coordinate with the inverter.

*The wire between the motor and the inverter has to be stored in shielded cable or metal tube. In addition, ground the motor terminal and the inverter terminal together. Please shorten the wire as much as possible.

*Please put this inverter in a metal cabinet that is already grounded. It can prevent radiation interference.

*The line-to-line noise filter at the power source terminal and the online magnetic iron core at the control row are used for suppressing noises.

All the signals and the EU-qualified filter specifications are described in details in the operation manual. Please contact your agent.

2. Low-voltage command (LVD):

(1). Low-voltage command compatibility description:

This inverter is compatible with low-voltage commands.

(2). Compatibility:

Our company qualifies the low-voltage command specification.

(3). Description:

*Do not rely on leakage protection only for preventing electric shocks. Grounding is required for the protection.

*Ground each inverter individually (do not connect more than two (including two) ground cables).

*Please use non-fuse switch and electromagnetic contactor that qualify EN or IEC specifications.

*Please use the inverter under an environment of over-voltage level-2 condition with contamination level 2 or better.

*For the style and dimensions of the input- and output-end of the inverter cable, please refer to the specifications listed in the operation manual.

EU-Declaration of Conformity

Herewith we(manufacture):	
Name:	SUZHOU SHIHLIN ELECTRIC & ENGINEERING CO., LTD.
Address:	NO.88, Guangdong St., Suzhou New District, Jiangsu, China.

Declare that the following Appliance complies with the appropriate basic safety and health requirements of the EU Directives(see Item 4) and the relevant Union harmonisation legislation based on its design and type, as brought into circulation by us.

The object of the declaration is identification of electrical equipment allowing traceability.

The declaration relates exclusively to Shihlin products in the state in which it was placed on the market, and excludes components which are added and/or operations carried out subsequently by the final user.

This declaration of conformity is issued under the sole responsibility of the manufacture.

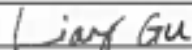
1	Product name:	Inverter
2	Model/Type:	SC3 Series (Reference the attached list of catalogue numbers)
3	Batch or Serial number:	Reference the attached list of catalogue numbers
4	Application EU Directives:	Low voltage Directive 2014/35/EU EMC directive 2014/30/EU RoHS Directive 2011/65/EU, (EU)2015/863
5	Used harmonized Standards:	LVD: EN 61800-5-1:2007/A11:2021 EMC: EN IEC 61800-3:2018
6	Signed for and on behalf of:	SUZHOU SHIHLIN ELECTRIC & ENGINEERING CO., LTD.
7	Print Name, Function(Title of Signature)	Liang Gu, Senior Vice President
8	Signature	
9	Place and date of issue	Suzhou of China, 2022.1.12
<p>Manufacturer Statement:</p> <p><i>✓ We shall give the manufacturer full name and address, registered trade name or registered trade mark, and true Batch/series no., "xxxx-xxxx" in the EU declaration and on the product(marking plate), or where that is not possible, on its packaging or in a document accompanying the product.</i></p> <p><i>✓ We shall keep the technical documentation referred to in Annex III and the EU declaration of conformity for 10 years after the electrical equipment has been placed on the market.</i></p>		

Catalogue numbers:

Series name	Model name	Serial number ¹
SC3-043 Series (3PH 440V)	<i>SC3-043-0.4K-xy, SC3-043-0.75K-xy, SC3-043-1.5K-xy, SC3-043-2.2K-xy, SC3-043-3.7K-xy, SC3-043-5.5K-xy, SC3-043-7.5K/11KF-xy, SC3-043-11K/15KF-xy, SC3-043-15K/18.5KF-xy, SC3-043-18.5K/22KF-xy, SC3-043-22K-xy</i>	N/A
SC3-023 Series (3PH 220V)	<i>SC3-023-0.2K-xy, SC3-023-0.4K-xy, SC3-023-0.75K-xy, SC3-023-1.5K-xy, SC3-023-2.2K-xy, SC3-023-3.7K-xy</i>	N/A
SC3-021 Series (1PH 220V)	<i>SC3-021-0.2K-xy, SC3-021-0.4K-xy, SC3-021-0.75K-xy, SC3-021-1.5K-xy, SC3-021-2.2K-xy</i>	N/A

- 1) *If no series number is given, then all series are covered*
2) *xy: denote any alphanumeric suffix*

8. REVISION RECORD

Published Date	Edition of the Manual	Revision Content
July 2015	V1.00	First edition
February 2016	V1.01	modify: 1. Modification of factory values and setting ranges of some parameters 2. Add Appendix 5: Compatibility Description of European Standards
June 2016	V1.02	modify: 1. Modify the communication line specifications in 7.4.4 2. Modify the cooling method of individual models in 3.1 electrical specifications add: 1. Add 3.7.3 grounding torque table
June 2016	V1.03	modify: Modify the parameter P.31, the second option, when P.72 > "5", change to when P.72 > "9" add: Added 7.4.4 DU10 operator
September 2016	V1.04	increase: 1. Add the description of P.XXX in 1.3 modify: 1. Modify the description of V indicator in 4.1(d) 2. Modify 3.1 Inverter weight
November 2016	V1.05	modify: 1. Fix some errors
March 2017	V1.06	modify: 1. Modification of factory values and setting ranges of some parameters 2.3.6.3 Delete A frame model add: 1. Add 5.7.7 to earth leakage current protection 2. Add 5.11.3 current filtering 3. Add 5.1.7 PWM carrier frequency rated current and carrier frequency curve diagram
September 2017	V1.07	modify: 3.7 Terminal wiring diagram
December 2017	V1.08	modify: 7.5 Appendix 5: Compatibility Description of European Standards 2.1 Nameplate description
January 2018	V1.09	modify: 3.5.3 Installation instructions: ambient temperature matters needing attention when installing multiple units
April 2018	V1.09+	modify: 3.6.3 Regenerative braking resistor
June 2018	V1.10	modify: 3.7 Terminal wiring, delete output signal add: 7.6 Appendix 6: WEEE Mark
May 2019	V1.10+	modify: 3.6.3 Delete A frame model
June 2019	V1.11	add: 1. Add 5.1.4 When the inverter starts, it will automatically enter the monitoring mode to display the current constant pressure system target pressure and feedback pressure 2. Add 5.7.8 Input phase loss protection option
October 2020	V1.12	add: 1.5.2.13 Remote control frequency acceleration and deceleration time selection 2. 5.9.4 PID current feedback disconnection detection 3.5.10.11 Voltage stall action level modify: Improve some parameter descriptions
May 2021	V1.13	add : 5.7.11 Fire mode modify : Improve and optimize the description of some parameters

Published Date	Edition of the Manual	Revision Content
May 2022	V1.14	add : 1. frame C/D support 2. 3.4.2 Frame C/D 3. 3.8.2 Frame C/D 4. 5.1.12 Motor types selection modify : Improve and optimize the description of some parameters

Version : V1. 14